

# **CHARTER SCHOOL APPLICATION**

## **Eliada Academy**

**Schools opening in the fall of 2013**

**See Resource Manual for Assistance**

**Due by 12 noon Friday, April 13, 2012**

North Carolina Department of Public Instruction  
NCDPI/Office of Charter Schools  
301 N. Wilmington Street  
Raleigh NC 27601-2825  
919-807-3491

Mailing Address:  
6303 Mail Service Center  
Raleigh, NC 27699-6303

# APPLICATION COVER PAGES

NAME OF PROPOSED CHARTER SCHOOL: Eliada Academy  
 NAME OF NONPROFIT ORGANIZATION/MUNICIPALITY UNDER WHICH CHARTER WILL BE ORGANIZED OR OPERATED: Eliada Academy, Inc..  
 HAS THE ORGANIZATION APPLIED FOR 501(c)(3) NON-PROFIT STATUS: Yes  No

Provide the name of the person who will serve as the primary contact for this Application. The primary contact should serve as the contact for follow-up, interviews, and notices regarding this Application.

NAME OF CONTACT PERSON: Mark Upright  
 TITLE/RELATIONSHIP TO NONPROFIT: President/CEO  
 MAILING ADDRESS: 2 Compton Drive  
 PRIMARY TELEPHONE: 828-254-5356 ALTERNATE TELEPHONE: 828-226-6692  
 E-MAIL ADDRESS: mupright@eliada.org

Location Proposed Charter School (LEA): Buncombe County/Asheville City Schools

Conversion:

No:

Yes:  If so, Public or Private:

If a private school, give the name of the school being converted: Eliada Academy  
 If a public school, give the name and six-digit identifier of the school being converted:

Description of Targeted Population:

The target population is children and adolescents, ages 6-18, with one or more mental health diagnoses on Axis I or Axis II (DSMIV,) severe behavioral issues, who have been or are at risk of removal from their homes, are below grade level and have been unsuccessful in traditional and other alternative school settings. Students are involved in the mental health system or DJJ System.

Eliada Academy is requesting a waiver of the minimum enrollment requirement.

Proposed Grades Served: 01,02,03,04,05,06,07,08,09,10,11  
 Proposed Total Enrollment: 67

Projected School Opening Year 2013 Month August

School Year	Grade Levels	Total Projected Student Enrollment	Year Round
First	01,02,03,04,05,06,07,08,09,10,11	67	Y
Second	01,02,03,04,05,06,07,08,09,10,11	67	Y
Third	01,02,03,04,05,06,07,08,09,10,11	67	Y
Fourth	01,02,03,04,05,06,07,08,09,10,11	67	Y
Fifth	01,02,03,04,05,06,07,08,09,10,11	67	Y

I certify that I have the authority to submit this application and that I was regularly involved in the development of this application. All information contained herein is complete and accurate, realizing that any misrepresentation could result in disqualification from the application process or revocation after award. I understand that incomplete applications will not be considered. The person named as

the contact person for the application is so authorized to serve as the primary contact for this application on behalf of the applicant.

  
Signature

Title President/CEO

Printed Name Mark C. Upright Date 4/12/12

**II. TABLE OF CONTENTS FOR THE APPLICATION**

Please provide a clear and precise table of contents to the proposed charter application that guides the reader through the document in correct sequence as outlined in the application provided.  
See Above

Eliada Academy Charter School Application

II. TABLE OF CONTENTS

<b>APPLICATION COVER PAGES</b>	<b>4</b>
<b>III. MISSION, PURPOSES AND EDUCATIONAL FOCUS</b>	<b>6</b>
EVIDENCE FOR NEED OF THE PROPOSED SCHOOL	6
GOALS FOR THE PROPOSED CHARTER SCHOOL	7
PURPOSES OF PROPOSED CHARTER SCHOOL-DOWNLOAD	7
EDUCATIONAL FOCUS	7
<b>IV. GOVERNANCE</b>	<b>9</b>
PRIVATE NONPROFIT CORPORATION (G.S.115C-238.29E)	9
TAX-EXEMPT STATUS (501 (C ) (3))	9
PROPOSED EDUCATIONAL MANAGEMENT ORGANIZATION	9
ORGANIZATIONAL STRUCTURE OF PRIVATE NONPROFIT	10
ADMISSIONS POLICY	12
<b>V. EDUCATION PLAN</b>	<b>12</b>
INSTRUCTIONAL PROGRAM	12
SPECIAL EDUCATION	19
STUDENT CONDUCT AND DISCIPLINE	20
TIMELINES-DOWNLOAD	21
PRIVATE SCHOOL CONVERSIONS	21
<b>VI. BUSINESS PLAN</b>	<b>23</b>
PROJECTED STAFF	23
QUALIFICATIONS REQUIRED FOR INDIVIDUAL POSITIONS	25
ENROLLMENT AND BUSINESS PLAN	25
PROJECTED ENROLLMENT 2013-14 THROUGH 2017-2018	27
BUDGET: REVENUE PROJECTIONS 2013-2014 THROUGH 2017-2018	28
BUDGET (CONTINUED): REVENUE PROJECTIONS 2013-2014 THROUGH 2017-2018	29
BUDGET (CONTINUED): EXPENDITURE PROJECTIONS 2013-2014 THROUGH 2017-2018	30
BUDGET NARRATIVE	31
WORKING CAPITAL AND/OR ASSETS ON DATE OF APPLICATION	32
SCHOOL AUDITS-PROGRAM-DOWNLOAD	32
SCHOOL AUDITS-FINANCIAL AUDITS-DOWNLOAD	33
CIVIL LIABILITY AND INSURANCE	33
TRANSPORTATION	33
FACILITY-DOWNLOAD	34
HEALTH AND SAFETY REQUIREMENTS	35
<b>VII. LEA IMPACT STATEMENT</b>	<b>37</b>
<b>VIII. APPENDICES</b>	<b>37</b>

**Eliada Academy Charter School Application**

---

**II. TABLE OF CONTENTS**

COVER AND APPENDICES TABLE OF CONTENTS	
APPENDICES 1 OF 5	1-89
APPENDICES 2 OF 5	90-111
APPENDICES 3 OF 5	112-147
APPENDICES 4 OF 5	148-234
APPENDICES 5 OF 5	235-289

<b>IX. SIGNATURE PAGE</b>	<b>290</b>
---------------------------	------------

---

## **MISSION, PURPOSES and EDUCATIONAL FOCUS (G.S.115C-238.29A)**

### **MISSION:**

*The mission of the proposed charter school is as follows:*

---

The Eliada Academy (EA) mission is: Helping Children Succeed: Creating an optimal learning environment that empowers children and families to succeed. EA provides an optimal learning environment that promotes students academic and behavioral success in and beyond EA. The children served have many special needs and most often come to EA in a state of crisis. Helping them succeed takes many forms, most importantly, normalizing routines with the familiar structure of school, which serves as the foundation for delivering and integrating the treatment they were admitted to EA to receive. Students who attend EA have rarely experienced success, academically or otherwise. EA gives them a real chance to catch up and be students who succeed.

### **EVIDENCE FOR NEED OF THE PROPOSED SCHOOL:**

*Describe the community relationships forged in the preparation of the charter application. Provide information detailing how the community and parents have been involved in the formation of the proposed mission statement. Evidence of surveys, dates, times, and locations of public meetings discussing this proposed charter school can be used to demonstrate the level of public interest.*

---

EA will serve children and adolescents who are in treatment and not enrolled in their home school for the duration of treatment. This population of students have been suspended, expelled, significantly truant and have missed significant blocks of instruction due to inappropriate, violent and often oppositional behaviors. They need support to make the academic gains that will facilitate their success when they are discharged and transition back to their home school. While in treatment, usually between six and eight months, sometimes as long as a year or more, students need academic support and the opportunity to maintain what they have learned and with the goal of making academic gains that will put them as close as possible to their age-mates when they return to their home school. What happens academically during treatment is where EA comes in. Currently, with private school accreditation, academics are an important aspect of treatment. With a Charter license, education can take the next steps toward providing an even higher quality academic experience and funnel education funds to the children who have the rights to this additional support while in treatment.

Historically, Eliada Homes, Inc. has identified many needs and has transformed its services in response to those needs for over 100 years, most often for children. EA, charter school, is the next transformation. See Appendix: Historical Perspective of Eliada Homes, Inc. p. 1; Annual Report, p. 4; Strategic Plan, p. 68; Fall Newsletter, p. 52

Following the proceedings of the case of Hoke County and Asheville City Boards of Education v. North Carolina State Board of Education, it is asserted that "at-risk students require intervention to provide for an equal opportunity for a sound basic education" ([http://nces.ed.gov/edfin/pdf/lawsuits/Hoke\\_v\\_NC\\_III.pdf](http://nces.ed.gov/edfin/pdf/lawsuits/Hoke_v_NC_III.pdf)). While this case particularly emphasizes the need for early childhood intervention, the Court also concluded, therein that the right of each child in North Carolina to receive a sound basic education may not be conditioned on age, but is to be conditioned on the needs of the individual child (p.21). While there are currently alternative school programs for at-

risk middle-school and secondary aged children in the Western North Carolina area, there are not currently any school programs that place an emphasis on integrating mental health therapeutic objectives within the academic context the way EA does for students. With the prevalence of mental health disorders in school-aged children, the effects of mental health disorders on learning and the need for early and targeted intervention (<http://www.childrenshealthfund.org/sites/default/files/chronic-illness-and-school-performance.pdf>), clearly the educational program proposed by EA is needed to serve this target population and provide the state-mandated right to a free, sound, basic education. Appendix: Success Stories, p. 72

### **GOALS FOR THE PROPOSED CHARTER SCHOOL:**

*A description of the student achievement goals for the school's educational program and the method of demonstrating that students have attained the skills and knowledge specified for those goals. These goals should include specific and measurable performance objectives over time. A timeline should be included to highlight how the school proposes to meet its objectives.*

---

For many students, placement at EA in either the residential or day program is their last best chance for success. Students are placed at EA for treatment of their mental health issues and are admitted with a treatment plan that includes specific academic goals. The Target Population of students with severe behaviors and mental health diagnoses are placed at Eliada for an average length of stay of six to eight months according to program evaluation data. Students are admitted and transition out of Eliada as their mental health needs dictate and these dates do not necessarily align with a traditional school year calendar. (Appendix: A Brief Overview Program Evaluation Report FY 2011, p. 81) EA will be a 12-month program, with students entering and leaving according to their progress in treatment and the consensus of their Child and Family Teams (CFT), the court system and other factors. Outcome-based Measures are set annually for accomplishment by EA. Appendix: 2011-2012 FY Outcomes Measurement Framework: Eliada Homes, Inc., p. 89

Goal 1: Students will demonstrate growth of one or more grade levels in English/Language Arts and Mathematics

Goal 2: Students who achieve below grade level will have an individualized plan developed for them which aligns with the objective of showing academic progress of one or more grade levels in English/Language Arts and Mathematics. Appendix: Student Education Plan (SEP), p. 108

Goal 3: Students who complete treatment at Eliada will successfully transition home and return to traditional or alternative public school. Appendices: Transition Plan 1, p. 112; Transition Plan 2. p. 120  
Timeline:

Each student who is admitted to EA, is given their own timeline at admission. The process for education, treatment and transition is consistent for all students, the actual time in the program will vary, depending on student needs and circumstances. Appendix: Goals Timeline, p. 78

### **PURPOSES OF PROPOSED CHARTER SCHOOL:**

*State the relationship between the six legislated purposes, as specifically addressed in the NC charter school statute GS 115C-238.29A, and the proposed school's operations.*

---

See State the relationship between the six legislated purposes [Download](#)

### **EDUCATIONAL FOCUS:**

*Describe briefly, limited to one page, the focus of the proposed charter school. This description will be used in public releases of information to interested parties, such as: the media, the State Board of Education, parents, school systems, and in various documents produced by the Office of Charter Schools. It must be concise and relate directly to the mission of the school.*

---

Eliada Academy is designed to serve, educate and treat students with acute mental health issues and behavior problems via therapeutic and academic interventions necessary to prepare them for success as a lifelong learner in academic and workforce worlds. The target population consists of students ages 6-18, who come from cultures of poverty, abuse and/or neglect and who have been diagnosed with one or more mental health disorders and often with educational special needs. The integrated methodology provides a multi-faceted approach that immerses and engages students in experiential learning in a safe, structured and disciplined environment. Students focus on building a foundation of basic academic skills, practice of social skills, self-control and expansion of experience and learning. Learning opportunities integrate academic and therapeutic objectives, demonstrating the connections between academics, discipline, personal transformation and lifelong success and well-being. While exploring academic concepts and ideas, students engage in higher order thinking and deep understanding of academic objectives corresponding to daily life applications. Therapeutic objectives include identifying patterns, feelings and emotions that provide roadblocks to success and learning replacement behaviors to increase the likelihood of success when the student re-enters the traditional school setting and community. Eliada Academy provides a holistic culture of personal growth, self-reflection, and critical thinking that promotes a successful return to home and community. Positive Behavior Intervention and Support (PBIS) initiatives integrate and support this holistic endeavor of education.



## **PURPOSES OF PROPOSED CHARTER SCHOOL**

### **Eliada Academy will:**

**\*Improve student learning** through the implementation of innovative, research-based educational practices designed to meet students' unique, individual learning styles. Pedagogy will focus on the utilization of discovery learning, inquiry-based learning and cooperative learning practices and emphasize the development of appropriate student conduct, positive peer relations, personal organization and formative self-assessment. Academic instruction will focus on enriching students' understanding of integrated academic content, where students are exposed to new curriculum material while reviewing and mastering core concepts to establish connections between fundamental skills and higher-order thinking, deep knowledge and comprehensive understanding.

**\*Increase learning opportunities for students, especially those identified as academically at-risk (or academically gifted,)** through the use of an educational model that integrates behavior modification treatment with academic learning. Class sizes are small with ratios of one staff to three students in the residential program and one staff to four students in the day treatment program. Teachers work in partnership with a treatment specialist to implement a therapeutic model of behavior modification. Therapeutic models allow students the opportunity to perform and learn in a supportive environment that is structured to facilitate significant improvement in behaviors and academic achievement. The models used at Eliada Academy (both the day treatment and residential classrooms) provide a learning environment for this target population of children and adolescents with mental health diagnoses to be successful learners of academic content and to replace ineffective and inappropriate behaviors and habits with those that demonstrate success in school and the community.

**\*Encourage the use of varied, differentiated and innovative teaching methods and insure compliance and efficacy** with a regular regime of supervision, observation and evaluative dialog with the director. Educators will focus on continuous improvement measured by periodic evaluations that identify areas for improvement, develop strategies for improving teaching and learning and set goals for continued development of instructional skills.

**\*Create new professional opportunities for teachers** by engaging teachers in an ongoing process of evaluation and improvement of the educational model. Educators will participate in continuing and sustained professional development to sharpen skill in the content areas, instruction and assessment and teaching at-risk children and adolescents. Educators will research, experiment with and reflect on research-based educational methods and concepts.

**\*Expand educational opportunities to the local community** by providing students with acute mental health issues and who have distinct special education needs, an opportunity to engage in a therapeutic and supportive learning environment. Students within our target population, whose success in public schools has been diminished by lack of access to appropriate support and accommodation, will have access and choice of opportunities for educational success through the treatment-enriched curriculum provided at Eliada Academy.

**\*Hold all stakeholders accountable for meeting measurable, performance-based student outcomes,** using standardized evaluation tools for student and teacher performance. Goals of

continual, formative growth and development for students and educators will drive the program. Student learning will be evaluated by local and state measures. In the event that teachers do not meet the expected performance standards and show a deficiency in one or more areas, a mentor teacher will be assigned to assist them in improving their skill set, additional professional development and coaching will be scheduled and more frequent observations will monitor progress toward improvement. Administrative evaluation will include an annual financial audit and the Eliada Academy Board will receive financial reports on a monthly basis.

## IV.GOVERNANCE

**NOTE:** Please answer all sections completely. Do not use "same as LEA" or "whatever the law states". Lack of proper documentation will jeopardize the application review.

### **PRIVATE NONPROFIT CORPORATION (G.S.115C-238.29E)**

The nonprofit corporation must be officially authorized by the NC Secretary of State by the final approval interview date.

Name of Private Nonprofit: Eliada Academy  
Mailing Address: P.O. Box 16708  
City/State/Zip: Asheville NC 28816  
Street Address: 2 Compton Drive  
Phone: 828-254-5356  
Fax: 828-259-5384

Name of registered agent and address:  
Mark Upright J.D., M.B.A.  
Attorney at Law  
2 Compton Drive  
Asheville, NC 28816

FEDERAL TAX ID:

### **TAX-EXEMPT STATUS (501 (c)(3) (G.S.115C-238.29B(b)(3))**

The private nonprofit listed as the responsible organization for the proposed charter school has 501(c)(3) status:

Yes (copy of letter from federal government attached) :

X No

### **See Tax Exempt Status Letter Download**

**NOTE:** The tax-exempt status must be obtained from the Internal Revenue Service within twenty-four (24) months of the date the Charter Application is given final approval. (G.S.115C-238.29E(b))

### **PROPOSED EDUCATIONAL MANAGEMENT ORGANIZATION (EMO OR CMO)**

If the Charter School plans to contract for services with an "educational management organization" or "charter support organization," please specify the name of the company, address, website, phone number, contact person, fax, and email:

- Please include a copy of the proposed management agreement of the specified EMO and explain how the contract will be in the best educational and financial interests of the charter school.

See Proposed EMO management agreement Download

- What other EMO/CMOs were pursued and why did the applicant select this particular one? Please include information regarding other management fees and financial/academic records that led to the selection of the

*proposed EMO/CMO as the best fit for this proposed school.*

---

- *Provide and discuss performance and financial data from other schools managed by the management company to demonstrate how this organization is a good fit for the proposed population of students*
- 
- *Describe how the governance structure will be affected; if at all, by the EMO/CMO and particularly discuss how the board of directors of the charter school will govern the school independently of the EMO/CMO. An organizational chart showing the lines of authority should be included.*
- 
- *Explain how the contract includes measurable objectives whereby the charter school board can evaluate annually the performance of the EMO/CMO; and if necessary, terminate the contract without significant obstacles.*
- 

**ORGANIZATIONAL STRUCTURE OF PRIVATE NONPROFIT:** (GS 115C-238.29B(b)(3); GS 115C-238.29E(d))

*The private nonprofit corporation is the legal entity that has responsibility for all aspects of the proposed charter school. Its members should reflect the ability to operate a charter school from both business and education perspectives.*

***Please provide the following in this location of the APPLICATION: (Do not include as an appendices.)***

- *A well-defined organizational chart showing the relationship of the Board of Directors to the parents and staff of the proposed charter school as well as any advisory council. This chart should also include lines of authority to and from any outside entity that will play a role in managing the charter school.  
See Organization Chart Download*
  - *Each founding board member must submit, in this section of the application, a one-page resume highlighting his or her experiences over the past ten or more years.  
See Resume Downloads*
  - *The proposed by-laws, which must include a Conflict of Interest Policy for board members and a stated commitment to the NC Open Meetings Law. (G.S.143.318.9 et seq)  
See Proposed By-laws Download*
  - *A copy of the articles of incorporation, if available. If not available, must be available prior to interview by SBE, so must show that it has been applied for prior to submission of application.  
See Articles of incorporation Download*
  - *A description of the governing board's functions, duties, roles and responsibilities as it relates to overseeing the charter school and its mission.*
- 

The Eliada Academy Board of Trustees will meet quarterly to review and approve policies and procedures presented by the President/CEO, Senior Leadership, and the Eliada Academy Director. The Trustees will receive written reports from Eliada Academy and agency leadership one week in advance of each meeting. The Trustees will also hear reports from the Budget/Finance Committee and Program Development Committee.

With due consideration of the recommendations of the Eliada Academy and Senior Leadership Team, the Board of Trustees will have final approval of all school policies, curriculum and academic programs. The Board of Trustees is a governing board that will expect the President/CEO, Eliada Academy Director and Senior Leadership to carry out the policies set by the Board of Trustees. The

# Organizational Structure of Eliada Academy

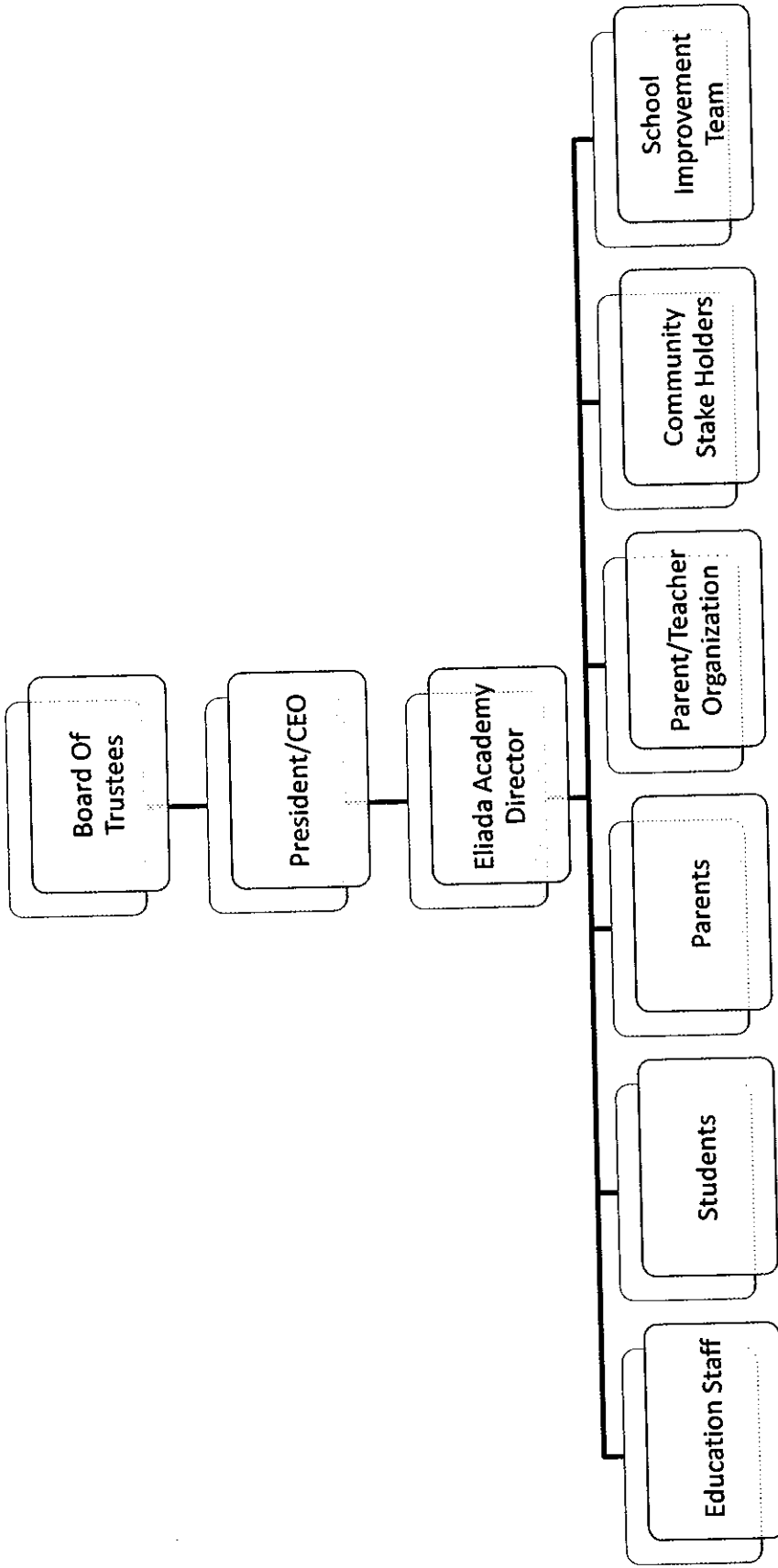

## **Stephen H. Harris**

Steve Harris is currently the Director of Business Development for Crescent Health Solutions, a health management company based in Asheville, North Carolina. As part of his responsibilities, Steve analyzes the performance of health plans and works with senior management to develop and implement long-range strategic plans to improve the health of employees and to maximize the impact of health care programs and investments.

Steve has worked as a management consultant for a variety of companies:

- SNF Chemical Company, the world's largest manufacturer of water-soluble flocculants;
- MasterFoods, formerly M&M Mars Corporation;
- Electronic Data Systems, global provider of IT outsourcing, and
- NOVO Nordisk, global pharmaceutical manufacturer.

Steve continues to provide management training for the U.S. Army Corps of Engineers.

Before starting his consulting career, Steve was the North American Vice President of Allied Colloids, a specialty chemical manufacturer. He was responsible for all sales, marketing, and technical service activities in agriculture, coatings, mining, oilfield, personal care, resale, and textiles markets. Steve also worked for both Texaco and Getty Oil Company in research, technical service, sales, and management of global projects.

Steve received his Ph.D. in Fiber and Polymer Science from North Carolina State University in 1979. Steve specializes in strategic account management, negotiations, and teaching interpersonal and management skills to professional and technical people.

Resume Board Member

Gary Roberts

35 Woodfin Street, Suite 307  
Asheville, NC 28801  
250-4909  
[gary.roberts@buncombecounty.org](mailto:gary.roberts@buncombecounty.org)

- Received a BS in Business Administration (in Management, Banking and Finance) at Mars Hill College
- Employed by Buncombe County as its Tax Director
- Member of the North Carolina Association of Assessing Officers-Legislative Committee
- Member of the North Carolina Tax Collectors Association-Board Director
- Volunteer: Consumer Credit Counseling Service and United Way of Asheville
- Types of Organizational Experience: Government and Non-Profit
- Areas of Experience: Administration, Business, Finance, Planning, Public Relations and Real Estate
- Interests/Hobbies: Golf, reading and gardening

Resume: Board Member

**Kevin Westmoreland**

3 Boston Way  
Asheville, NC 28803  
274-2439

[kevin.p.westmoreland@gmail.com](mailto:kevin.p.westmoreland@gmail.com)

- Received a BS in Management at the University of North Carolina –Asheville
- Self Employed Restaurant Owner, Corner Kitchen
- Member of the Asheville Independent Restaurant Owners Association
- Member of the Better Business Bureau
- Member of the Chamber of Commerce
- Board of Directors, WNC Historical Association
- Interests/Hobbies: Photography, Environmentalism



Cromer Lee Crisp, Jr.  
14 Lynnstone Court  
Asheville, N. C. 28805  
(828) 299-4549  
[lee.crisp@hotmail.com](mailto:lee.crisp@hotmail.com)

## VITA

### Education

- 1986-1989 EDS in School Administration, Western Carolina University, Cullowhee, N.C.
- 1981-1982 S.G. Curriculum Instructional Specialist 1 – Educational Supervision, Western Carolina University, Cullowhee, N.C.
- 1977-1982 M.A. in Learning Disabilities, Appalachian State University, Boone, N.C.
- 1973-1977 B.S. in Teaching, Mentally Handicapped, Appalachian State University, Boone, N.C.

### Professional Experiences

- July, 2005 to June, 2007: Director of Special Services, Buncombe County Public Schools, Asheville, N.C.
- July, 1988 to June, 2005: Assistant Director of Special Services, Buncombe County Public Schools, Asheville, N.C.
- July, 1984 to June, 1988: Supervisor, Programs for Exceptional Children, Buncombe County Public Schools, Asheville, N.C.
- August, 1979 to July, 1984: Instructional Resource Specialist, Programs for Exceptional Children, Buncombe County Public Schools, Asheville, N.C.
- January, 1977 to June, 1979: Special Education Teacher, Weaverville Primary, Buncombe County Public Schools, Asheville, N.C.

Jayne R. McDonald  
76 Hillcrest Drive  
Weaverville, NC 28787  
(828) 658-3605  
[jaynermcd@charter.net](mailto:jaynermcd@charter.net)

## VITA

### Education

- 1982 S.G.; Curriculum Instructional Specialist; Western Carolina University; Cullowhee, NC.
- 1980 M.A.; Special Education with Behavioral Disorders; Furman University; Greenville, SC.
- 1969 B.S.; Teaching, Special Education; Greensboro College; Greensboro, NC.

### Professional Experiences

- 1998-2005: Behavioral Specialist; Buncombe County Schools; Asheville, NC.
- 1988-1998: Service Coordinator; Asheville City Schools; Asheville, NC.
- 1981-1988: Special Education Teacher; Henderson County Schools; Hendersonville, NC.
- 1978-1981: Educational Coordinator; Eckerd Wilderness Camps; Hendersonville, NC.
- 1976-1978: Owner and Director; Stay and Play Day Care Center; Hendersonville, NC.
- 1973-1976: GED and Adult Education Teacher; Asheville-Buncombe Technical Community College; Asheville, NC.
- 1971-1973: Special Education Teacher; Buncombe County Schools; Asheville, NC.
- 1969-1971: Special Education Teacher; Wake City Schools; Raleigh, NC.

### Prior Teaching Certifications

Mental Retardation; Learning Disabilities; Behavior and Emotionally Handicapped; Other Health Impaired; Cross Categorical. Grades K-12.

**BYLAWS OF  
ELIADA ACADEMY, INC.**

ARTICLE I

NAME, PRINCIPAL OFFICE AND GENERAL PURPOSES

Section 1. Name. The name of this Non- Profit Corporation is:

ELIADA ACADEMY, INC.

Section 2. Principal Office: The principal office of the Corporation shall be in Asheville, North Carolina. The street address of the initial registered office of the Academy is: 2 Compton Drive, Asheville, NC 28806 and the name of the initial registered agent at such address is Mark Upright, Attorney at Law.

Section 3. Purposes. The purposes for which this Corporation is organized shall be as follows:

- (a) To establish and maintain educational programs and opportunities for primary and secondary students who are diagnosed with Mental Health and/or Behavioral Problems.
- (b) To operate a charter school under the Charter School Act of 1996, as codified in the North Carolina General Statutes 115C-238.29A as now enacted or hereafter amended.
- (c) To carry on any lawful activities calculated, directly or indirectly, to promote the purposes and interests of the Corporation and its Mission as permitted by a nonprofit corporation pursuant to Chapter 55A of the North Carolina General Statutes, consistent with those portions of section 501(c)(3) of the Internal Revenue Code of 1986, as amended, relating to educational organizations, the provisions of the Act and other applicable laws.

ARTICLE II

TRUSTEES

Section 1. Number. The Board of Trustees shall consist of a minimum of 5 members and a maximum of 10 members. The actual number of Board members shall be determined from time-to-time at the discretion of the Board. Directors will serve terms of four years, or until their successors assume office.

Section 2. Election. New Board members shall be elected at the annual meeting of the Trustees. The Trustees shall be chosen by ballot at such meeting by plurality vote of the Trustees present.

Section 3. Absence. Trustees not active in committee assignments and missing three (3) consecutive Board meetings may be asked to resign. Written and/or verbal communications to the non active Trustee will be handled by the Chair of the Board of Trustees. Reinstatement shall be in the sole discretion of the Board.

Section 4. Vacancies. Any vacancy in the Board of Trustees occurring during the year, including a vacancy created by an increase in the number of Trustees, may be filled for the unexpired portion of the term by majority vote of the Trustees then serving. Nominations to fill any vacancies shall be made by any current Board member. Any Trustee so elected by the Board of Trustees shall hold office until the next succeeding annual meeting of the Board of Trustees or until the election and qualification of his or her successor.

Section 5. Annual Meeting. The annual meeting of the Board of Trustees shall take place each year on a date selected by the Trustees, at a place chosen by the Trustees. Notice of the annual meeting shall be governed by Section 8 below. Immediately after the election of Trustees at the annual meeting, the new Board of Trustees shall elect Officers and transact any other appropriate business.

Section 6. Regular Meetings. Regular meetings of the Trustees shall be held at least quarterly. Regular meetings of the Board of Trustees shall be held with notice as provided in Section 8 at such time and place as shall be determined by the Board of Trustees.

Section 7. Special Meetings. Special meetings of the Board of Trustees may be called by the Chair or Vice Chair and must be called by either of them on the written request of two members of the Board.

Section 8. Notice of Meetings. Regular Meetings of the Board of Trustees shall be held from time to time at such times and such places as the Board of Trustees may prescribe. Notice of the date, time, place or purpose of each such meeting shall be given in advance of said meeting.

Section 9. Chair. At all meetings of the Board of Trustees the Chair or Vice Chair, or in his or her absence a Chair chosen by the Trustees present, shall preside.

Section 10. Quorum. At all meetings of the Board of Trustees a majority of the Trustees then in office shall constitute a quorum for the transaction of business and the majority of the Trustees present at any meeting at which there is a quorum shall be the act of the Board of Trustees, except as may be otherwise provided by

these bylaws. If at any meeting there is less than a quorum present, a majority of those present may adjourn the meeting to a future date, no more than twenty days after the date of the meeting so adjourned, with three days written notice to any absent Trustee.

Section 11. Proxies. Trustees entitled to vote on any matter before the Board may do so only in person and not by proxy.

Section 12. Conflict of Interest. No Trustee shall take any action to influence the conduct of the Corporation so as to confer financial benefit on another corporation business, or family in which the Trustee has a significant interest or affiliation. If an issue arises on which the Trustee could obtain a benefit for himself or herself, he or she must refrain from participating in the discussion and voting on the matter, but may present an opinion, if he or she discloses in advance the potential conflict of interest. –In addition the corporation shall comply with the voting and disclosure provisions of the Trustee conflict of interest section of the Non-Profit Corporation Law NCGS 55A-8-31.

Section 13. Compensation. Trustees and Officers shall serve without compensation.

Section 14. Powers. All corporate powers, except such as are otherwise provided for in these bylaws and in the laws of the State of North Carolina, are vested in and shall be exercised by the Board of Trustees. The Board of Trustees may by general resolution delegate to committees, whose members need not be Trustees, such powers as they may see fit, except as limited by statute.

### ARTICLE III

#### NON-DISCRIMINATION

Eliada Academy, Inc. does not discriminate on the basis of race, color, religion, sex, age, national origin, marital status, military status, sexual orientation, handicap or disability in employment and in admission and access to its educational programs and activities, in compliance with applicable federal and state laws.

### ARTICLE IV

#### MEMBERSHIP

The corporation shall not have members.

Section 1. Number. The Officers of this Corporation shall be:

1. Chair
2. Vice Chair
3. Secretary
4. Treasurer

Section 2. Election. All officers of the Corporation shall be elected biennially by the Board of Trustees at their annual meeting and these elected officers shall hold office for a term of two (2) years or until their successors are duly elected and qualified.

Section 3. Tenure of Office. Any Officer of the Corporation may be dismissed at any time during his or her term by a majority vote of the Trustees at any regular, special or adjourned meeting of the Board of Trustees. When an Officer is dismissed in the manner herein described, he or she shall have no power or authority under or by virtue of his or her former office.

Section 4. Combination of Offices. Any of the offices above enumerated, other than the office of the Chair and Vice Chair, or Chair and Secretary, may be combined.

Section 5. Duties of Officers. The duties of the Officers shall be as follows:

- (a) The Chair shall preside at all meetings of the Board, preserve order, appoint all committees, with the approval of the Trustees, and deliver an annual report of the condition of the Corporation to the Trustees at the Corporation's annual meeting. The Chair shall perform all other duties usually incumbent upon such officer and as required by the Board.
- (b) The Vice Chair shall preside at all meetings in the absence of the Chair and shall perform such other duties as may be required by the Board.
- (c) The Secretary shall have custody of the seal of the Corporation and shall affix the same to all instruments requiring the seal when and as directed by the Board. The Secretary shall review and sign all recorded meeting minutes. The Secretary shall see that true and correct records are kept of all meetings held by the Board. Copies of meeting minutes will be provided to each board member. The Secretary shall give, under direction of the Chair, the necessary notices of all meetings and shall prepare all correspondence of the Board. The Secretary shall perform such other duties as are required by the Board.
- (d) The Treasurer shall see to the receipt of all monies and securities of the Corporation and the deposit of all funds of the Corporation

to its credit in such banks as the Board shall direct. All disbursements of funds, except petty cash accounts, shall be by check signed by any two persons from a group of persons designated as eligible for such purpose by the Board. At the end of each fiscal year, a detailed statement of such receipts and disbursements shall be submitted to the Board of Trustees for their approval. The books of the Corporation shall at all times be subject to audit. Upon request and with Board agreement information concerning the financial operations of the Corporation shall be furnished to agencies or individuals contributing substantially to the support of the Corporation.

- (e) The President/CEO shall be the chief executive officer of the corporation and shall have general supervision over the business of the corporation, subject to the control of the Board of Trustees. The President/CEO shall see that all orders and resolutions of the Board of Trustees are carried into effect. The President/CEO shall perform such other duties and have such authority and powers as the Board of Trustees may from time to time prescribe.

Section 6. Vacancies. All vacancies in any office shall be filled by the Board of Trustees at a special meeting called for that purpose within 10 days after the occurrence of such vacancy. Any Officer so elected by the Board of Trustees shall hold office until the next succeeding annual meeting of the Board of Trustees or until the election and qualification of his or her successor.

## ARTICLE V

### AGENTS AND REPRESENTATIVES

The Board of Trustees may appoint such agents, employees and representatives of the Corporation with such powers and to perform such acts or duties on behalf of the Corporation as the Board of Trustees may see fit, so far as they are consistent with these Bylaws, and to the extent authorized or permitted by law. The Board shall employ a President/CEO for the administration of the programs and policies of the Corporation. The President/CEO shall direct the operations of the Corporation and shall be answerable to the Board in all matters. The President/CEO shall employ, and whenever necessary discharge, such staff members as may be deemed necessary for the proper operation of the Corporation.

## ARTICLE VI

### CONTRACTS

The Board of Trustees, except as otherwise provided in these Bylaws, may authorize any Officer or agent to enter into any contract or execute and deliver any instrument in the name and on behalf of the Corporation, and such authority may be general or confined to a specific instance, and unless so authorized by the Board of Trustees, no Officer, agent or employee shall have any power or authority to bind the Corporation by any contract or engagement, or to pledge its credit, or to render it liable pecuniary for any purpose or in any amount.

## ARTICLE VII

### COMMITTEES

Section 1. General. The Board of Trustees shall create and maintain, from their number, the standing committees described in Section 2, together with additional standing and ad hoc committees as required. Except as otherwise provided in this Article, the members of all such committees shall be appointed by the Chair. Committee members shall serve at the pleasure of the Board of Trustees. Such committees shall advise and aid the Officers and Trustees of the Corporation in all matters designated by the Board of Trustees. Each such committee may, subject to the approval of the Board of Trustees, prescribe rules and regulations for the conduct of meetings of the committee and other matters relating to its procedure. Unless otherwise stated herein, a majority of the Trustee members of each committee shall constitute a quorum for the transaction of business. The members of committees shall not receive any compensation for their services.

Section 2. Standing Committees. Standing committees shall include the following:

- (a) Budget/Finance Committee. The Budget Committee shall be knowledgeable in all phases of the annual budget and financial planning for the organization. The committee shall meet with the President/CEO and the Eliada Academy Director to develop the proposed budget for the next fiscal year and shall then recommend this budget to the Board, in regular session, for approval. The committee shall be charged with reporting to the Board, in regular session, a summary of the financial condition of the previous quarter. The Treasurer shall be a member of this committee.
- (b) Program Committee. The Program Committee shall be knowledgeable in all aspects of reviewing educational programs, survey information and program improvement reporting measures. The Committee may collaborate with the President/CEO, Eliada Academy Director and other Academy employees to review program evaluations models including



outcome measures, review annual evaluation reports, longitudinal survey reports, review improvement strategies and additional developmental plans.

## ARTICLE VIII

### PERIOD OF ACCOUNTING AND REPORTING

The fiscal year shall begin on July 1 and shall end on June 30.

## ARTICLE IX

### PROHIBITION AGAINST SHARING IN CORPORATE EARNINGS OR ASSETS; DISSOLUTION

No Trustee, Member, Officer, employee, member of a committee, or other person connected with the Corporation, or any other private individual, shall receive at any time any of the net earnings or pecuniary profit from the operations of the Corporation. No loans may be made by the Corporation to any Officer or Trustee. No such person shall be entitled to share in the distribution of any of the corporate assets upon the dissolution of the Corporation. All Trustees and Officers of the Corporation shall be deemed to have expressly consented and agreed that upon such dissolution or winding up of the affairs of the Corporation, the assets of the Corporation shall be distributed, transferred, conveyed, delivered and paid over in compliance with the NC Charter Schools Act §115C-238.29F(i) - Upon dissolution of the charter school or upon the nonrenewal of the charter, all net assets of the charter school purchased with public funds shall be deemed the property of the local school administrative unit in which the charter school is located.

Those assets not purchased with public funds shall be distributed, transferred, conveyed, delivered and paid over to such eleemosynary institution or institutions upon such terms and conditions and in such amounts and proportions as the Board of trustees may determine, to be used by such institutions for the same or similar purposes as are set forth in the Certificate of Incorporation of this Corporation as amended, and to be dedicated for exempt purposes within the meaning of Section 501 (c) (3) of the Internal Revenue Code of 1986 as amended.

## ARTICLE X

### ACTION BY CONSENT; PARTICIPATION

Section 1. Written Consent. All actions taken require a meeting by the required majority of the Trustees and then shall constitute the official action of the Board, and shall be binding on the Corporation. A written consent of such action will be signed by all the Trustees and filed as part of the official minutes of the meetings of the Board of Trustees, whether such consent is signed and dated before or after the action is taken.

Section 2. Participation. Any one or more Trustees or members of a committee may participate in a meeting of the Board or committee by means of a conference telephone or similar communications device which allows all persons participating in a meeting to hear each other, and such participation in a meeting shall be deemed presence in person at such meeting.

## ARTICLE XI

### INDEMNIFICATION

Any person who at any time serves or has served as a Trustee, Member, Officer, employee or agent of the Corporation shall be indemnified by the Corporation to the extent required by North Carolina General Statutes, Chapter 55A, Sections 17.1, 17.2 and 17.3 and their statutory successors, and may in the discretion of the Board of Trustees, be indemnified to the extent permitted by such statutes, against (a) reasonable expenses, including but not limited to attorney's fees, actually and necessarily incurred by him or her in connection with the defense of any threatened, pending or completed action, suit or proceeding in which he or she is made a party by reason of being or having been such Officer, Trustee, Member, employee or agent and (b) reasonable payments made by him or her in satisfaction of any judgment, money decree, fine, penalty, or settlement for which he or she may become liable in any such action, suit or proceeding.

The Board of Trustees shall take all such actions that may be necessary and appropriate to authorize the Corporation to pay any indemnification required by this Article, including without limitation a good faith evaluation of the manner in which the claimant for indemnity acted and of the reasonable amount of indemnity due to him or her.

The corporation shall purchase insurance on behalf of Trustees or others against liability asserted or incurred by her or him in that capacity arising from his or her status as a trustee, officer, employee or agent, whether or not the corporation would have the power to indemnify him or her.

## ARTICLE XII

### AMENDMENTS

Except as otherwise provided by law, the Board of Trustees shall have power to make, alter, amend and repeal the Bylaws of the Corporation by the affirmative two-thirds (2/3) vote of the Trustees then serving, provided that a copy of the proposed change is included with a notice of such meeting mailed or transmitted by electronic means to each Trustee at least two weeks before the meeting.

State of North Carolina  
Department of the Secretary of State

ARTICLES OF INCORPORATION  
NONPROFIT CORPORATION

Pursuant to §55A-2-02 of the General Statutes of North Carolina, the undersigned corporation does hereby submit these Articles of Incorporation for the purpose of forming a nonprofit corporation.

1. The name of the corporation is: Eliada Academy
2.  (Check only if applicable.) The corporation is a charitable or religious corporation as defined in NCGS §55A-1-40(4).
3. The street address and county of the initial registered office of the corporation is:  
Number and Street 2 Compton Drive  
City, State, Zip Code Asheville, NC 28816 County Buncombe
4. The mailing address *if different from the street address* of the initial registered office is:  
\_\_\_\_\_
5. The name of the initial registered agent is:  
Mark C. Upright, J.D., M.B.A. - Attorney at Law
6. The name and address of each incorporator is as follows: \_\_\_\_\_  
Mark C. Upright, 905 Woodvine Road, Asheville, NC 28803; 60 Court Plaza, Room 315, Asheville, NC 28801  
Kevin Westmore, 3 Boston Way, Asheville, NC 28803
7. (Check either a or b below.)  
a.  The corporation will have members.  
b.  The corporation will not have members.
8. Attached are provisions regarding the distribution of the corporation's assets upon its dissolution.
9. Any other provisions which the corporation elects to include are attached.
10. The street address and county of the principal office of the corporation is:  
Number and Street 2 Compton Drive  
City, State, Zip Code Asheville, NC 28816 County Buncombe
11. The mailing address *if different from the street address* of the principal office is:  
\_\_\_\_\_

**Attachment to Articles of Incorporation – Eliada Academy**

8. In the event of termination, dissolution or winding up of the affairs of the corporation in any manner or for any reason whatsoever, the Directors shall, after paying or making provisions for payment of all liabilities of the corporation, distribute all of the remaining assets of the corporation to and exclusively for ELIADA HOMES, INCORPORATED, or its corporate successor if it shall then exist as an organization organized and operated exclusively for religious, charitable, educational, scientific, or literary purposes under Section 501 (c)(3) of the Code; otherwise as its Directors may determine among one or more organizations which are then organized and operated for exempt purposes and qualified as exempt organizations under Section 501 (c)(3) of the Code and to which contributions are then deductible under Section 170(c) (2) of the Code or to federal, state and local governments to be used exclusively for public purpose.

12. These articles will be effective upon filing, unless a later time and/or date is specified: \_\_\_\_\_

This is the 29 day of March, 20 12.

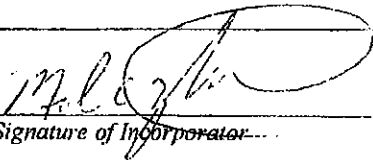
  
\_\_\_\_\_  
*Signature of Incorporator*

Mark C. Upright, J.D., M.B.A. Attorney at Law  
\_\_\_\_\_  
*Type or print Incorporator's name and title, if any*

NOTES:

1. Filing fee is \$60. This document must be filed with the Secretary of State.

Revised January 2000

CORPORATIONS DIVISION

P. O. BOX 29622

Form N-01

RALEIGH, NC 27626-0622

Eliada Academy Director and staff will be responsible for the day to day operation of the school.

- *Explain the decision-making processes the board will use to develop school policies.*
- 

The Eliada Academy Board Of Trustees will have the foundation and support of the Board of Trustees of Eliada Homes, Inc. and Eliada Foundation, Inc. These two corporations with over 110 years of history, utilize well defined planning, evaluation, and reporting mechanisms to ensure transparency of operations and the effective and efficient use of resources to achieve the organization's mission.

The Eliada Academy Board of Trustees will participate and develop a Strategic Plan for three year durations. The plan is then divided into short term and long term strategic objectives. Each objective identifies a measurable goal and time frame for completion. This plan is updated to the Board of Trustees at every quarterly meeting to ensure objectives are being achieved.

The Board of Trustees will also have the benefit of In-house counsel along with specific legal, human resource, and financial organizations to assist them in the development and implementation of policies and procedures that are in compliance with North Carolina Law and directives from DPI.

Additionally, the Board of Trustees will have access and executive summaries on performance based testing goals, student and parent satisfaction surveys, teacher satisfaction surveys, results from EOG and EOC from the agency's Quality Management and Compliance department to determine areas for improvement and development.

- *Portray how the board will involve parents and community members in governing the school.*
- 

The Board of Trustees current members include a retired educator/behavioral specialist, retired school administrator, health care administrator, county tax director and local entrepreneur. As we add Board of Trustee members, our goal will be to seat a parent of a student or former student; a legal educational advocate; and a medical or educational professional in the area of cognitive development.

It is our plan to form a Parent/Teacher Organization to encourage full participation and advocacy for the families and educators of the school community.

- *Describe the organization's performance-based goals and measurable objectives for the charter school. Organizational goals and measurable objectives should describe and measure the effectiveness and viability of the organization.*
- 

Goals for the organization Eliada Academy, Inc. focus on Helping Children Succeed, by creating a learning environment that empowers children and their families to succeed. Goal 1 addresses academic growth; Goal 2 addresses remediation and support for students who are not making expected progress; and Goal 3 addresses the successful transition of students from Eliada Academy back to their local school and/or home. Please reference a detailed description of the Goals in the section labeled: GOALS FOR THE PROPOSED CHARTER SCHOOL and the section: INSTRUCTIONAL PROGRAM, bullet number three: Demonstration that selected goals are clear, measurable, ambitious and attainable.

- *Describe how the governing board will ensure that current and future board members avoid conflicts of interest.*
- 

The Eliada Academy Board of Trustees will review the Conflict of Interest Policy with its members

when they are initially appointed to the Board and annually thereafter . A written policy will be provided and each member will need to sign and date the Conflict of Interest Policy annually.

**ADMISSIONS POLICY** (G.S. 115C-238.29B(b)(4); G.S. 115C-238.29F(d)(1))

*Provide a description of the policies and the procedures for admitting students to the proposed charter school, including specific details of the enrollment lottery plan, statutorily allowed preferences, a plan to develop clear procedures for withdrawals and transfers, as well as subsequent marketing strategies to reach all demographic groups.*

---

EA serves a unique population that has severe mental health and behavioral issues and fills a gap in services to students who have failed in the traditional, public school environment. All students are required to have a current Psychological Evaluation and/or a Comprehensive Clinical Evaluation prior to application.

EA does not discriminate against any student on the basis of ethnicity, national origin, gender or disability.

EA will not limit admission to students on the basis of intellectual ability, measures of achievement or aptitude, athletic ability, disability, race, creed, gender, national origin, religion or ancestry.

In the event a lottery becomes necessary, priority shall be given to students with Mental Health Diagnoses and/or significant behavior problems.

To conduct the lottery drawing an official will conduct the drawing during an Eliada Academy, Inc. Board meeting.

## V. EDUCATION PLAN

**NOTE:** Answer all sections completely, include your answers in this section of the application, do not include as an appendices. Do not use "same as LEA" or "whatever the law says". The State Board of Education shall give priority consideration to the applicants who demonstrate potential for significant, meaningful innovation in education. Give explanations. Lack of proper documentation will jeopardize the application review.

**INSTRUCTIONAL PROGRAM:** (G.S. 115C-238.29F (d))

*Provide a detailed description of the overall instructional program, including the following:*

- Educational theory, foundation of the model, and proposed innovative offerings.
- 

EA offers a unique population an innovative learning environment that blends project based learning, and traditional academic skills along with social and emotional learning into a curriculum that teaches academic and social skills in a real world context.

Students enrolled at EA have specific mental health diagnoses and educational needs. Often our students lack the skills to function within the parameters of a traditional classroom due to mental health symptoms. EA utilizes Aggression Replacement Training and Skills Streaming alongside rigorous academic structure in order to help the student adapt to real life both in and outside of the classroom. Both strategies implement role playing and the taking of alternate perspectives as an approach to social problem solving and moral decision making.

EA students are most engaged when they are actively learning. The Revised Blooms Taxonomy, moves learn from a thing to an action; from a noun to a verb and that result in students making

connections and performing at higher levels, often reaching the level of Creating (see Appendices: Revised Bloom's Taxonomy, p. 93; Model for Learning Objectives, p. 90). Every class at EA employs Project Based Learning as a strategy to build community, teamwork and collaboration. Teachers help students find a sense of teamwork and belonging through various team and group based activities across the curriculum. In a 2008 article in the Journal of Research in Science Teaching, Dr. Robert Geier, et al, find that "project based learning tends to be more effective than traditional instruction in increasing academic gains on state assessment tests as well as being more effective in terms of long-term retention, skill development and satisfaction of students and teachers" (Journal of Research in Science Teaching, 45(8), 922-939).

EA uses the following questions to drive curriculum design and instruction:

1. What is important for students to learn in the limited school and classroom time available? (The Learning Question)
2. How does one plan and deliver instruction that will result in high levels of learning for large numbers of students? (The Instruction Question)
3. How does one select or design assessment instruments and procedures that provide accurate information about how well students are learning? (The Alignment Question)
4. How does one ensure that objectives, instruction, and assessment are consistent with one another? (The Alignment Question)

Source: Anderson, L.W., & Krathwohl, D.R. (Eds.), Airasian, P.W., Cruikshank, K.A., Mayer, R.E., Pintrich, P.R., Raths, J., & Wittrock, M.C. (2001). A taxonomy for learning, teaching, and assessing: A revision of Blooms taxonomy of educational objectives. New York: Addison Wesley Longman, Inc.

Inquiry-based learning is integral in the utilization of EAs rich community and therapeutic resources, including: therapeutic recreation and arts, TASC (Therapeutic Animal Stewardship Collective, NYPUM (National Youth Program Using Minibikes by Honda), PAWS with a Mission, NAVITAT, UNCA Athletics, ABTECH, and more. Educators will utilize more innovative, collaborative, student-centered practices, particularly for students with exceptional learning needs.

EA educators do whatever it takes to help students learn and be successful. The students that are admitted with learning deficits have the opportunity to work hard and with support, increase their ability to read and understand, compute and understand numbers and learn how to learn, proving that every child can learn and grow.

- *Teaching approach, class structure, curriculum design, courses of study, sample daily schedule, pillars of the school culture, and instructional methodology that align with the school's mission.*

---

Teaching Approach, Instructional Methodology, Curriculum Design, Course of Study and Class Structure: Multiage classrooms provide benefits to academic and social/emotional learning and grouping students in smaller classes allows for more targeted intervention and support. The mixed-age classrooms at EA will have no more than nine students and no less than three staff in the residential classrooms and not more than eight students and no less than two staff in the day treatment classrooms. These ratios are required by licensing and accreditation boards and are also justified for safety reasons. Classrooms have common expectations and rules which are reviewed at the beginning of each block or activity. Students thrive in this very structured and consistent environment. Small class size also allows for significant rapport building between students and staff, provides ample opportunity for one on one attention and tutoring and creates a climate of support and success. Teachers will use engaging, problem-based curricula to integrate concepts across academic disciplines. Teachers will use of a variety of pedagogical styles relevant to accessing students' individual learning styles and needs. Students will be engaged in both collaborative and individual learning tasks in a variety of forms, from individually tailored skills practice to classroom games and



group projects. Appendix: Curriculum Design, p.94

Because many EA students are typically deficient in language arts and math, these two subjects will be the core focus, enhanced by enrichments with modern themes from social studies and science. Essential Questions will be used to scaffold students' thinking and inspire inquiry as they explore various problem situations. Technology will be an integration tool and vehicle to extend learning. Teachers will follow the six standards published by International Standards for Technology Education (ISTE) to advance learning and to enhance the use of Blooms Taxonomy in teaching and learning. All these components together assure our delivery of 21st Century Skills to our students.

1. Creativity and Innovation: Students demonstrate creative thinking, construct knowledge, and develop innovative products and processes using technology.
2. Communication and Collaboration: Students use digital media and environments to communicate and work collaboratively, including at a distance, to support individual learning and contribute to the learning of others.
3. Research and information Fluency: Students apply digital tools to gather, evaluate and use information.
4. Critical Thinking, Problem Solving and Decision Making: Students use critical thinking skills to plan and conduct research, manage projects, solve problems, and make informed decisions using appropriate digital tools and resources.
5. Digital Citizenship: Students understand human, cultural and societal issues related to technology and practice legal and ethical behavior.
6. Technology Operations and Concepts: Students demonstrate a sound understanding of technology concepts, systems and operations. Appendix: ISTE/NETS for Students, p. 99

#### Daily Schedules

Students on the campus of EA are in school from approximately 8:15 AM until 2:45 PM. Middle School and High School aged students attend four, 75-80 minute blocks of instruction and have a 30 minute Homeroom/Breakfast to start the day. Elementary students are in school for the entire school day and their time is divided in to activity blocks of various lengths. Appendix: Class Schedules, pp. 101-102

#### Pillars of the School Culture

The Pillars of our School Culture are built on the foundation of our Core Values of Teamwork, Excellence and Integrity, Faith, Hope and Love. Appendix: Pillars of School Culture, p. 103

- *Demonstration that selected goals are clear, specific, measurable, ambitious and attainable.*

---

EA has a Framework for Outcome Measurement with ambitious and attainable outcomes, supporting the whole child, with goals for academics and successful transition into the community. Most students who are admitted to EA have been unsuccessful in public school primarily due to serious behavior problems. The secondary issue is that academic learning suffers due to suspension, expulsion and significant truancy. EA's mission of Helping Children Succeed addresses all of these issues and sends the student back to the traditional public school with skills and knowledge to be successful.

Appendices: pp. 89, 81, 112, 120

Goal 1: 55% of students will demonstrate growth by successfully increasing their achievement one or more grade levels in English/Language Arts and 45% in Mathematics as measured by the BASI (Basic Achievement Skills Inventory) at admission, at three months and at discharge. Progress will be tracked on the Student Education Plan (SEP) see Appendix: Student Education Plan, p. 108. Passing End of Course assessments or End of Grade assessments will also demonstrate and document academic progress. Since most students of EA achieve well below grade level, this is an ambitious goal and is attainable because of the focused attention on building basic skills, Title One support and focused

remediation for those who need extra support to meet this goal. Appendix: BASI, p. 104-105  
Goal 2: Students who achieve below grade level will have an individualized Student Education Plan (SEP) which aligns academic progress of one or more grade levels in English/Language Arts and Mathematics. Individualized Education Plans (IEP) will be implemented for students with an Exceptional Children status. Growth will be measured by student achievement, which is reflected in the SEP reviewed every three weeks. IEP teams will review plans annually and as needed. Students who have not had an IEP, but who do meet the criteria for Exceptional Children services will have an IEP Team develop a plan for them. Each student has staff advocate that also reviews academic progress with them and communicates with the teachers and the child's CFT. Appendix: Student Education Plan, p. 108

Goal 3: 50% students will have improved social, emotional and behavioral function in the home and educational settings. Improvements in the affective are measured by assessments and inventories completed at admission and discharge. During treatment, students practice social skills and replacement behaviors within the framework of the instructional day and 24/7 for students who reside on campus.

Goal 4: Students who complete treatment will successfully transition home and return to a traditional or alternative public school. Comprehensive transition plans are developed for students at admission and evaluated and revised during treatment. Appendix: Transition Plans. At the completion of treatment, students return to their parent or guardian, to therapeutic foster care/group homes and to more traditional school settings. When students come to Eliada, they have been in between one and 34 treatment placements. When they transition out of Eliada, 68% of students maintain a placement in public school.

The four primary goals for student achievement at EA make clear statements about how much progress students are expected to make and what percentage of students will be able to demonstrate this level of progress. Growth will be measured by the BASI and state assessments. Student goals are ambitious in the fact that a) students are only enrolled at EA for an average of six months, b) many students are one or more grade levels behind in both language arts and math, and c) students have acute mental health issues that significantly increase the difficulty of achievement. Multiple supports, academically and therapeutically, are in place to facilitate the attainment of these ambitious goals. EA Leaves No Child Behind. Appendix: EA Logic Model, p. 142

- Entrance and exit requirements as well as graduation requirements (if the school is to be high school).

#### Entrance and Exit Requirements

Students who have been admitted to EA have one or more of the following characteristics:

##### Academic:

- Significantly behind grade-level in reading and math skills
- Have missed significant blocks of instruction
- Have the capacity to learn and grow
- Are primarily kinesthetic and auditory learners
- Lack confidence in their learning abilities
- Show progress when focus is on academic strengths
- Have a strong dislike for school and academics in general

##### Behavioral

- Demonstrate oppositional behaviors to camouflage learning deficits or avoid academics
- Have been removed from previous educational setting for inappropriate and often, violent behaviors
- Act out and go off task to avoid academics
- Practice learned helplessness
- Have a diagnosis of Attention Deficit Hyperactivity Disorder (ADHD) and have extreme difficulties paying attention, sitting still and focusing on instruction
- Lack appropriate social skills and peer relations

## Mental Health

- Are diagnosed with significant mental health disabilities and one or more diagnoses
    - o Axis I and Axis II from DSM-IV
  - Predominantly Oppositional Defiant Disorder, Post Traumatic Stress Disorder
  - Mood and personality disorders: Bipolar, Major Depressive
    - o Have a traumatic and neglected past
  - Are medicated with psychotropic medications that affect energy, appetite, sleep cycles, and general feelings of well-being
  - Have been removed from their family of origin: therapeutic foster care, adoption, residential care
  - Are oppositional defiant toward any authority figure or request
- Appendix: Basic Demographics, p. 287

All students must have a complete and current Psychological Evaluation and/or a Comprehensive Clinical Evaluation prior to application. Students with mental health diagnoses are assisted by a mental health agency for applications and testing requirements and have a Child and Family Team to support their treatment.

When students are discharged from EA and transition back to their home school, they have improved their foundational skills in reading and math, learned better ways of communicating with teachers and other adults, improved their ability to relate to peers, learned new social skills, practiced good study skills and emotionally and behaviorally more stable and able to return to a larger school and classroom setting and be successful.

- *The school calendar (must provide instruction for a minimum of 185 instructional days) (G.S.115C-238.29F(d)(1)) and how it coincides with the tenets of the proposed mission.*
- 

Eliada Academy is requesting a waiver to operate as a year-round school. The Instructional Program will begin prior to August 25 and will conclude by June 30. Total 2013-2014 School Days: 222

Eliada Academy is in session throughout the year with short breaks for holidays, and between semesters and the summer session. The reason for the extended year is due to the need for consistency and continuity in delivering treatment and maintaining academic structure for the students. When they are absent from school for more than a few days (even in the residential program where students are supervised 24/7,) it undermines their ability to retain and maintain their new social skills and behaviors. Academic achievement is also reinforced with a year-round schedule, with less time for students to forget what they have learned. Because students are only with us for a short time, it is also necessary to provide intensive support and interventions both academically and for treatment.

Attachment: EA School Calendar, p. 143

- *A concise description of any evaluation tool or test, if any, that the proposed charter school will use in addition to any state or federally mandated tests and how this data will be used to drive instruction and improve the curriculum over time for the benefit of students.*
- 

EA uses the BASI test to assess each student at admission, mid-placement and at discharge to measure academic growth during treatment.

The reports generated by the BASI test results provide diagnostic data to determine the strengths and weaknesses of individual students abilities in reading, writing and mathematics. The data is broken down into strands facilitate the development of a learning plan for individual students. As students are

tested, teachers will adjust lessons to strengthen the weak areas and extend learning in the areas that the students show strength. Frequently, the sequencing of instruction is altered to address the highest needs of the student first. These data also provide our Title One teacher with information that can be used in tutoring or support in the classroom. Appendix: BASI, p. 104; Appendix: BASI Report Format, p. 105

Assessment Timeline:

Appendix: Assessment Timeline, p. 145

- *Provide an overview of the professional development needs associated with the mission and proposed instructional program. Be sure this discussion matches with the funding of the budget section.*
- 

EAs Mission: Helping Children Succeed: Creating an optimal learning environment that empowers children and their families to succeed will drive professional development for teachers. Teachers will gain content area knowledge and expertise by attending workshops and training for the English and Mathematics programs that have been selected as foundational resources. Teachers will also attend workshops on technology to better equip them to use the MAC Books, iPods and iPads in the classroom. Ongoing training for Positive Intervention and Behavior Support will be attended in collaboration with local public and charter schools.

EA is also fortunate to have access to training in the Common Core Curriculum, Reading, Writing and Mathematics through the WRESA (Western Region Education Service Alliance.)

As part of the treatment program, EA staff will participate in campus-wide training for the various diagnoses and treatment issues of our target population at monthly Special Population trainings and workshops. Knowing more about the students being taught at EA will make teachers more effective teachers and students more effective learners.

- *An explanation of how the school will provide assistance to students that are not performing at expected levels to ensure the continued progress of student growth. The applicant needs to define their "expected levels" of performance and delineate a plan accordingly.*
- 

Teachers at EA will work intensively with students not performing at expected levels to assist them in achieving individual goals outlined in their SEP. The SEP will list specific strategies and interventions for those students that are tailored to assisting them achieve their goals, including previously used and known effective strategies gathered from the students academic history and/or IEP. The teacher will keep in mind that the student population often suffers from lack of achievement caused by their diagnoses and background. To that end, the teacher will collaborate with the student and their treatment team to adjust the SEP as needed, including, deleting and/or altering accommodations based on observations and trends in achievement data. Teachers will involve the students advocates in the process to ensure that rigor and achievement are supplemented outside the classroom. Incentives may be used as necessary to increase motivation, such as setting up academic motivators with advocates and restricting access to extra-curricular activities until the student is able to demonstrate improved progress toward their goals.

- *Details in how the proposed charter plans to involve parents and community members within the school.*
- 

EA believes that the success of the child's education and treatment are highly dependent on parent involvement in education and treatment. Students in the day treatment program of EA share information about their academic and behavioral day, every day when they go home from school and are required to get a parent signature on their homework and their behavior monitoring form. Parents can communicate daily with teachers via these documents or via email. Each student is assigned a

Case Manager who is in frequent, sometimes daily communication with parents and guardians and other members of the child's Child and Family Team (CFT.) Each child's CFT meets together, monthly, to discuss the child's progress in school and in treatment. The CFT will adjust goals, strategies and transition plans according to the progress or lack of progress that is made by the student at EA. Parents also sign a statement at admission that they agree to support their child's efforts at EA.

The community is highly invested in EA and the sister agencies, Eliada Homes, INC. and the Eliada Foundation. They offer support to the Annual Corn Maze fundraiser, sponsor an annual holiday party for children and their families, as well as EA staff and their families and sponsor a Spring Fling party for the students. The community also supports efforts at EA to build an awareness, appreciation and understanding of different cultures in our community and the world at large. Speakers, presentations and workshops for staff and students provide a well-rounded program of cultural competency.

Parents and community members serve as volunteers in many capacities as needed by EA. Privacy regarding treatment is always considered when accepting volunteer assistance and all volunteers go through a background check prior to mingling with the student population.

- *Describe how the school will meet the needs of gifted, at-risk children, English language learners by explaining the proposed school's process for identification and service of these students.*
- 

The very nature of the EA is intended to meet the needs of at-risk children. Having small classrooms with a low student to teacher ratio allows the teacher to observe and assess each student consistently on an individual basis. Involving community members and organizations allows the student to feel involved in the community, giving them a sense of purpose and drive. Some of the community organizations involved with EA students include: PAWS with a Mission, Brother Wolf, UNCA athletics, ABTech, Diana Wortham Theater, The tight-knit professional community at EA provides intensive collaboration and involvement to create an atmosphere of nurturing and growth for all. The mixed-age classroom setup at EA allow students to progress on their own goals at an individual pace, rather than feeling pressured by the parameters of their grade level. The student's SEP is used to monitor each student at their current level of achievement, and is implemented by the teacher to differentiate instruction and classroom design as needed to assure each student is successful in class. Students will take an active role in the drafting and reviewing of their SEP so they can feel in control of their progress, rather than feeling as though their learning is being micro-managed by authority figures. Teachers and clinical staff will work together, along with the student themselves, to target academic and emotional/behavior needs and how to best address them. The intended result is to create an optimal learning environment that actively engages the student in their process of learning, growth and reflection.

Gifted students will be identified either by academic review, teacher observation of consistently high intellectual aptitude, or by BASI testing data. Teachers will alter the SEP for such students to include appropriately challenging goals and strategies to allow the gifted learner to work in an environment appropriate for their learning styles. Monitored independent study tracks, individual projects, and higher grade-level work, geared toward critical analysis and use of divergent thinking skills, will be used to assure that the student is appropriately challenged. Student work will be aligned with the student's individual interests to maintain consistent levels of interest and motivation.

EA will screen for English Language Learners with a questionnaire upon enrollment. Staff members will be given training on how to best serve the ELL population. Classroom accommodations, extra tutoring, and using materials in the student's native language are some potential strategies EA will use to reach these students.

- *Discuss any proposed extra-curricular activities to be offered by the school and how these offerings match the over-all mission of the school.*

---

Students who participate in extra-curricular activities generally show a higher level of success and achievement in the other areas of their lives. Students with mental health issues and/or behavior issues benefit even more from exposure and participation in activities that are new and different from their usual routines (hanging out, getting into trouble, isolating, etc.) At Eliada Academy, the whole child receives treatment and education, often including extra-curricular activities and field trips.

On campus, students have the opportunity to make use of a fully equipped fitness center, climbing wall, gymnasium and a real mountain to explore and hike. Eliada Academy provides a Therapeutic Animal Stewardship Cooperative program that gives students a chance to learn about animals, how to take care of them and how they can teach us about ourselves. In the barn there are horses, a pot-bellied pig, a donkey, a goat and a llama for the students to groom and share secrets with.

Honda supports EA with a National Youth Program Using Minibikes (NYPUM) to teach character and how to ride dirt bikes. Annually, students who qualify participate in a National NYPUM Rodeo. EA has hosted this event and plans to host again in the summer of 2012.

A partnership with UNCA Athletic department provides students with the opportunity to learn how to play and participate in golf, tennis, basketball, softball, wrestling and other team and individual sports. Many students train and run 5K races in the community.

Students who qualify because of academic success and/or progress in treatment and who are responsible are able to be employed by the NYPUM or TASC programs and earn a small salary helping with the animals or bike maintenance.

A group of model train enthusiasts volunteer their time to teach EA students about model trains and building small dioramas that might be part of a larger model train track village or countryside. Other volunteers have taught students how to plant and tend gardens, paint murals, sew, build a labyrinth and shared many other gifts and talents with EA students.

Students at EA may take field trips to local theaters, sporting events, orchards and farms, recreation parks, the Blue Ridge Parkway, animal shelters, soup kitchens and retirement homes to learn about their community and ways they can serve others.

### **SPECIAL EDUCATION** (G.S.115C-106)

*The charter school must accept special needs children under the federal legislation Individuals with Disabilities Education Act (IDEA) (20 U.S.C. 1400 Et seq.) and the state legislation (G.S. 115C-106 Et seq.). The proposed school will abide by the charter school legislation, G.S. 115C-238.29F(g)(5), as stated below:*

*A charter school shall not discriminate against any student on the basis of ethnicity, national origin, gender, or disability. Except as otherwise provided by law or the mission of the school as set out in the charter, the school shall not limit admission to students on the basis of intellectual ability, measures of achievement or aptitude, athletic ability, disability, race, creed, gender, national origin, religion, or ancestry.*

*Provide a clear and thorough explanation of the procedures the proposed charter will follow to insure compliance of the above laws. As part of this section, the plan should include how you will identify and meet the needs of your projected students (at-risk, gifted/talented, English language learners, and students with disabilities) in a manner that aligns with the overall curriculum, instructional approach, and mission.*

---

EAs target population has consisted of 57.6% Regular Education and 34.44% Special Education and 7.95% of students with a 504 Plan. This number may change as students who arrive without Exceptional

Children accommodations and plans are found to be eligible for services under the statutes. IEPs will be reviewed and updated annually and if needed, developed for students who are not admitted with one. Additional support will come from Title I services. 98% of EA students qualify for Title I services. A checklist for the target population is used to determine eligibility. Appendices: Special Education; Title I; EA Title I Targeted Checklist, pp. 144, 146, 147

An individualized curriculum, experiential learning, high staff to student ratios and experienced staff delivering treatment for behavior issues will ensure that all students receive the service and support they need and are entitled to, to be successful. Students will be required to have a complete psychological evaluation and/or a Comprehensive Clinical Assessment (CCA.).

**STUDENT CONDUCT AND DISCIPLINE** (G.S.115C-238.29B(b)(12); G.S. 115C-238.29F(d)(4 and 5))

*Provide drafts, included in this section, of student handbooks and other policies governing student conduct and discipline. Include policies and procedures governing suspension and expulsion of students. Specifically address these policies with respect to exceptional children. Also describe how a parent could appeal the decision of a school administrator through a grievance process.*

---

Generally, students are neither suspended or detained at Eliada Academy. There are consequences in the classroom for serious behaviors and rarely is a student suspended or removed from the program. Each classroom staff will follow the behavior model for their program to determine consequences.

Intervention Continuum:

Natural Consequences (losing privileges, etc.)

Separation from the classroom

Special Staffing with EA personnel

Emergency CFT with child's entire team

Consultation with Psychiatrist on campus

Recommendation for a higher level of service

Expulsion with support from EA Board

All students and their parents or guardians are informed of the grievance procedure at or before admission to Eliada Academy.

**GRIEVANCE PROCEDURE:**

(1)The client presents grievance to the case manager. The case manager will:

- a) Acknowledge to the client in writing that the grievance has been received,
- b) Present the client with a copy of the current Client Grievance policy,
- c) Meet with the client to discuss and, hopefully, resolve the problem,
- d) Respond to the client with a written decision within 5 days of this meeting,
- e) File the grievance in a separate file entitled Client Grievances, not in the client record and,
- f) Forward copies of the grievance and all subsequent correspondence related to the grievance to program administration and Continuous Quality Improvement (CQI).
- g) If for any reason, a client cannot write, a grievance may be made verbally or written for the client.

(2) If after taking this action, the client does not feel that the problem has been resolved, he/she may submit the grievance to program administration. Within 5 days from receipt of the grievance, program administration will:

- a) Respond to the client with a written decision and
  - b)Forward additional copies of the response to the case manager and to CQI.
  - c)Notify the custodian and contracting agency.

(3) If the decision is still not satisfactory to the client, a final appeal may be made to the Chief Operations Officer of EHI. The Chief Operations Officer's decision will be final. Within 15 days from receipt of the grievance, the Chief Operations Officer will respond to the client with a written decision. Additional copies of this response will be forwarded to program administration, the case manager (for entry into the Client Grievances file) and CQI.

(4) The client will, at this point, direct any further appeal of the issue to their custodian/contracting agency.

(5) An annual summary of grievances will be reviewed by EHI's President/CEO and Board of Trustees.

(6) All grievances will be reviewed on a quarterly basis by the agency's Client Rights committee. Their findings/recommendations will be distributed to program administration and the appropriate CQI team for follow up or corrective action.

The attached policies are all drafts and will be edited to insert the name Eliada Academy upon approval. Appendices: Student Handbook, p.165; Behavior Management, p. 150, Grievance, p. 153; Restrictive Interventions, p. 155

**See Student handbooks and other policies governing student conduct and discipline Download**

### **TIMELINES**

*Please create and describe a detailed start-up plan, identifying major tasks, timelines, and responsible individuals for accomplishing those tasks.*

See Time Line Download

### **PRIVATE SCHOOL CONVERSIONS: complete ONLY if the proposed charter is a private school conversion.**

- *Provide a detailed description of the existing private school's financial status.*
- 

Appendix: Financial Statements 2010 and 2011, p. 191

- *Describe the rationale for converting from a private entity to a public school. Include information regarding how the proposed charter school will be nonsectarian in nature and will be open for all students (not just those currently attending the private school).*
- 

Currently, EA, Private School provides education to children and adolescents with significant mental health and behavioral issues. While students do get opportunities to further their academic skills, they do not receive a full array of services for special education or a completely balanced curriculum. There are also children who do not qualify for mental health services, who need the kind of intensive intervention that EA provides, in order to be successful in school. EA, Charter School removes all financial barriers and access to funding opens up the program to other students and creates an environment where these children can get the services they need. Charter School status provides the state mandated right to a free, sound, basic education to our targeted population. Converting to a Charter School supports the Mission and Goals of EA and supplies a population of students who frequently fall through the cracks and drop out



of school when they are old enough, an opportunity to be successful learners and citizens.

- *Depict and analyze the current enrollment trends of the school over the past three academic years.*
- 

The capacity for student enrollment is 67 students in Day (28) and Residential (39) programs. There are five residential cottages on campus and one day school with four classrooms (one elementary, one middle school, one high school and one mixed aged group of students with Asperger's diagnoses or traits.) Enrollment has increased slightly over the past three years. One reason for growth is that our residential program is one of few and the premier Psychiatric Residential Treatment Facility in Western North Carolina. Our Day Treatment program has competition from local schools and the census fluctuates from a low of 19 to a high of 27 in the past year. Appendix: Admission Trends, p. 196

- *Document and expound upon evidence that the existing private school is successful in student achievement. Base this explanation upon academic data available through summative assessments.*
- 

Outcome measures of a Longitudinal Follow up in 2011 documented that 86% of students are enrolled in school and of that, 68% are enrolled in public school. This is a significant success and demonstrates that the goals set for EA drive successful completion of the program for students who transition out of EA. Appendices: A Longitudinal Follow-Up, p.197; EA Powerful Progress Stories, p. 198; Success Stories, p.72; Academic Growth, p. 201

- *Explain the proposed charter school's expected staff turnover due to the statutory requirements for teacher licensure and highly qualified status.*
- 

No turnover is expected for Eliada Academy. Of the seven teachers employed, all have a degree and have passed the PRAXIS in their areas, with the exception of one English teacher who will take the middle school/secondary level of the PRAXIS for English Language Arts and an elementary teacher who is in the process of renewing her license. A Special Education teacher (or more depending on enrollment) will be hired to begin in August of 2013, as soon as the Charter Application is approved. Appendix: Resumes/Licenses, p. 207

## VI. BUSINESS PLAN

### **PROJECTED STAFF:**

*Provide a list of positions anticipated for the charter school; (e.g., principal or director; support staff; teachers, part-time and full-time; paraprofessionals/teaching assistants, clerical, and maintenance.)*

Position Name	Job Description
--Administrator(S)	President/CEO is responsible for the administration of the programs and policies of the Corporation.
--Clerical	Job Description downloaded and attached:
--Teachers	Job Description is downloaded and attached
--Librarians	Not applicable; will use current library and local public libraries
--Guidance	There are six full-time clinicians on staff that work with the Mental Health side of treatment and they will provide guidance functions.
--Teacher Assistants	N/A
--Custodian	Provided through centralized maintenance
--Maintenance	Maintenance is centralized
--Food Service	Food Service is centralized as part of the mental health services; Breakfast and Lunch are provided to all students
--Bus Driver	Staff are trained and licensed to drive Eliada Agencies vehicles
--Other	
Eliada Academy Director	Job Description is downloaded and attached; supervises, manages and evaluates education and treatment program for all students on Eliada Academy Campus

*Discuss how the school will develop, mentor, retain, and evaluate staff in a format that matches the school's mission and educational program. Please include a timeline, steps to be taken, and a lead contact.*

Eliada believes in the continuous professional development of staff through integrated training and supervision activities, in both formal and informal settings. Eliada will provide a comprehensive 80 hour pre-service training for academic staff. The training will include agency orientation/mission and core values; person centered thinking philosophy; common diagnoses; Mental Health service definitions; Therapeutic Crisis Intervention (28 hour curriculum); first aid, CPR and BBP; and training on specific evidence based treatment interventions used at Eliada. Teachers will have access to monthly special populations trainings focused on relevant treatment topics. In addition, teachers will attend academic related trainings offered in the local and state education community. Eliada fosters staff retention through an optimal work environment; involvement in quality improvement, evaluation and other committees; staff surveys; agency staff meetings; staff recognition by peers and agency. A formal professional development evaluation will be completed by each Teacher and the Director annually. The evaluation tool focuses on Eliadas core values and major job responsibilities. Improvement goals will be set and reviewed in regular supervision throughout the year. Staff development and evaluation will be managed by the Eliada Academy Director and the agency training coordinator.

*Also include the following information for the proposed charter school:*

- *Process to advertise for and employ members of the school*

Eliada advertises for staff through multiple venues including local newspapers; list serves;

professional associations; and others. We will also advertise open positions through placement offices of local schools of education. Recruitment and hiring will be facilitated by the agency Recruiter. The Eliada Academy Director will review all applications for employment; conduct interviews; and recommend hiring to senior administration.

- *Procedures for grievance and/or termination*
- 

Employee complaints will be handled through a dispute resolution procedure. Grievances and work related complaints must be submitted in writing to the Eliada Academy Director and the agency's Human Resources Director. Appeals can be made to the President/CEO and the Eliada Academy Board. A progressive discipline process is utilized to address job performance and employee conduct issues. The Director of Eliada Academy will address such issues through verbal and written feedback. Patterns and/or serious performance/conduct incidents will be addressed by the Director and could result in probation or suspension. Termination requires an Administrative Hearing with the President/CEO of the agency and includes a discussion of the written and verbal information on job performance and conduct with a final decision by the President/CEO. Terminated employees can request a grievance hearing with representatives of the Eliada Academy Board.

- *Sample employment policies to be implemented by the proposed charter school*
- 

**PRODUCTIVE WORK ENVIRONMENT:** It is the policy of Eliada Academy to promote a productive work environment and not to tolerate verbal or physical conduct by any employee that harasses, disrupts, or interferes with another's work performance or that creates an intimidating, offensive, or hostile environment. Special attention should be paid to the prohibition of written, verbal, emotional or physical sexual harassment. Any employee who believes that a supervisor/program director's, other employee's, or a non-employee's actions or words constitute unwelcome harassment has a responsibility to report situation as soon as possible. Any employee who is found to have violated the harassment policy will be subject to appropriate disciplinary action, up to and including termination.

**STANDARDS OF BEHAVIOR AND EMPLOYEE CONDUCT:** It is the policy of Eliada Academy that all employees are expected to comply with standards of behavior and performance and that any noncompliance with these standards must be corrected. Eliada Academy endorses a policy of progressive discipline in which it attempts to provide employees with notice of deficiencies and an opportunity to improve. Eliada Academy does retain the right to administer discipline in any manner it sees fit. This policy does not modify the status of employees as employees-at-will.

Conduct Subject to this Policy

Unintentional Violations

Intentional Misconduct that Does Not Constitute a Crime

Criminal Activity

It is the policy of Eliada Academy (EA) that conduct that interferes with operations, discredits EA, or is offensive to customers or coworkers will not be tolerated. Appropriate employee conduct includes: punctuality, giving advance notice of absences, adhering to safety and security regulations, abiding by the dress code, maintaining order in the work place, treating all students, families, visitors and colleagues with respect, working well as part of the team, protecting students from harm or neglect

- *Description, if the proposed charter school partners with an EMO, of the relationship that will exist between the*

charter school employees and the management company.

---

Does not apply

**See Handbooks governing standards of conduct, grounds for termination, policies and procedures, etc Download**

**QUALIFICATIONS REQUIRED FOR INDIVIDUAL POSITIONS:** (G.S.115C-238.29F(e))

*List the qualifications and appropriate licenses that each position must have to perform the job function(s). Describe the plan to meet the licensure requirements for teachers and paraprofessionals as prescribed by state law and No Child Left Behind. If individuals have already been identified for specific positions, please provide their qualifications and/or resumes in the appendices.*

---

Job descriptions that have been downloaded and attached have all requirements listed within the document.

Appendix: Resumes and Licenses of Staff, p. 207

See Qualification Required for Individual Positions Download

**ENROLLMENT and BUSINESS PLAN** (GS 115C.238.29F(g)(1-7))

*Provide a plan indicating how the school will reasonably reflect the demographic composition of the district in which the charter school will be located or of the special population the school seeks to serve: (G.S.115C-238.29F(g)(5)).*

---

Appendix: Basic Demographics, p. 287

The student population will match the demographics of the primary LEA, Buncombe County Schools. Eliada Academy will not discriminate against any student on the basis of ethnicity, national origin, gender, or disability. Eliada Academy will serve a vulnerable, high risk population with emotional and behavioral issues. A comprehensive clinical assessment and/or psychological evaluation will be required at referral to the school. Students must have a DSM-IV diagnosis on Axis I or II. Students served will have diagnosis such as Oppositional Defiant Disorder; Post Traumatic Stress Disorder; Depression; Mood Disorder; Bipolar Disorder, Conduct Disorder or others. Presenting reasons for referral will include self injurious behaviors, suicidal ideation, physical aggression, violence towards others, property destruction, running behaviors, substance abuse, sexualized behaviors, attachment issues, attention difficulties, and more. Most students will come from family histories of abuse, neglect, substance abuse, mental illness, domestic abuse/violence, and family structure characterized by chaos, frequent disruptions, and dysfunction. School behaviors will include aggression towards peers and adults, property destruction, disruptive, impulsive, stealing, suspension and expulsions, truancy, poor social interactions, fighting, anxiety, non compliance, and failing grades.

*Marketing to potential students and parents is vital to the survival of a charter school. Reaching the full capacity for enrollment will be critical to obtain the necessary financial resources to keep your school viable and operating efficiently. In addition, it is required by law that charter schools provide equal access to all students. Read the charter school State Statute regarding admissions GS 115C.238.29F(g) (1-7) carefully. Describe how the board will market the school to all populations (including various community ethnic groups, teachers and other employees, and the general public) to ensure that the school fully complies with the State Statute to mirror the diversity of the local education agency.*

---

Appendix: Flyers

The Eliada Academy Board will review and approve an initial and ongoing marketing plan developed by Eliada Academy and agency leadership staff to reach students and parents/guardians reflective of the demographics of Buncombe County Schools. Target audiences will include the general public, Mental

## Position Description

**Job Title:** Eliada Academy Director  
**Department:** Eliada Academy  
**Status:** Professional/Exempt

**Salary Grade:**

### Position Summary:

Under the direction of the Chief Operations Officer, the Eliada Academy Director is responsible for the development, implementation and service delivery of Eliada Academy and Day Treatment services.

### Major Responsibilities:

1. Academic/Service Delivery: Actively develops, implements and manages quality Charter School and Day Treatment Programs and delivery of academic and treatment services to students with mental health diagnosis.
  - a. Oversees a quality program of academic instruction and student learning.
  - b. Coordinates service delivery with case management, intake, clinical and other support services at the agency and in the community.
  - c. Participates in the ongoing development, implementation and evaluation of treatment/behavioral interventions and activities. Participates in the agency's evaluation and outcomes plan.
  - d. Ensures compliance with charter school, licensure, accreditation and agency standards and policies.
2. Supervises and manages staff assigned to Director's direct supervision.
  - a. Initiates weekly supervision, disciplinary action and performance evaluation of academic and treatment staff
  - b. Recommends the hiring of qualified Eliada Academy and treatment staff.
  - c. Provides supervision to QPs, APs and PPs according to NCAC and licensing guidelines.
  - d. Participates in the development and implementation of training and professional development for academic and treatment staff and for portions of pre-service training for all newly hired staff.
  - e. Ensures appropriate and adequate staff coverage at all times, maintaining 1: 6 QP and 1:4 staff to client ratios in the program.
3. Functions as liaison for Eliada Academy and Day Treatment Programs.
  - a. Develops and maintains relationships with community organizations, referral agencies, students/families and other members of the community.
  - b. Participates in leadership team for agency's education and treatment services. Includes shared oversight of agency's quality management, program development and evaluation; and clinical/best practices of care.
4. Participates in the preparation of budgets assigned to service areas.
  - a. Ensures monitoring and adherence to annual budgets.
5. Provides crisis management support and service delivery, including shared on call crisis services.

### Other Responsibilities:

1. Ensures the provision of quality services to students through participation in the agency's CQI processes.
2. Displays competence and responsiveness to cultural differences present in both student and employee population.
3. Performs other related administrative and management tasks as assigned by the Chief Operations Officer.

### Reporting Relationship:

Position reports to: Chief Operations Officer

Position supervises: Teachers, Program Manager, Case Managers, Administrative Assistant and Day Treatment staff.

### Qualifications:

#### Knowledge:

- A Master's degree in Education or related Human Services field from an accredited college or university. Must meet requirements and standards for a Qualified Professional.
- Requires knowledge of service delivery and behavioral management in social and behavioral health services.

#### Experience:

- Five or more years experience in the delivery of education and behavioral/mental health services.
- Two or more years supervisory experience.

**Skills:** Must possess a valid NC driver's license and insurability by the agency's insurers. This position requires on-call responsibilities. Requires ability to implement restrictive interventions. Position may experience verbal and physical aggression from the client population.

### Disclaimer Clause

Job descriptions are not intended, and should not be construed, to be exhaustive lists of all responsibilities, skills, efforts or working conditions associated with this job. They are meant to be accurate reflections of the principal job elements essential for making fair pay decisions. This position description is not intended as a contract. A Letter of Employment confirms employment. North Carolina is an at-will employment state and Eliada is an at-will employer.

## Position Description

**Job Title:** Teacher  
**Department:** Eliada Academy  
**Status:** Professional/Exempt

**Salary Grade:**

### Position Summary:

Under the supervision of the Eliada Academy Director, the Teacher will develop and implement curricula designed in accordance with the NC Standard Course of Study in order to help students learn subject matter and skills that will contribute to their academic development.

### Major Responsibilities:

1. Develop lessons for all students enrolled in the Eliada Academy in accordance with the NC Standard Course of Study, while differentiating for individual needs, various learning styles, and class dynamics. Completes weekly objective forms to document adherence to the curriculum.
2. Collaborates with the Treatment staff to provide behavioral supervision employing the Eliada Model in order to create a classroom environment that meets both the academic and treatment needs of the students. Ensures the safety of students by providing constant supervision and thoroughly and effectively using the agency's crisis intervention. Ability to perform physical restraint techniques as part of the agency's crisis intervention model.
3. Evaluates the academic progress of all students, which includes but is not limited to, preparing progress and grade reports by utilizing the computerized grading program, communicating academic progress to case managers, completing Student Education Plans and providing input for planning and implementing IEP goals and objectives.
4. Establishes and maintains a structures, safe and student-friendly classroom, which includes but is not limited to, active student engagement differentiation, clean and organized environment, clear and consistent procedures and expectations, and incorporation of school improvement components (i.e. school-wide writing approach, professional development, etc.) into instruction.
5. Obtains and maintains teaching certificate in accordance with North Carolina Department of Public Instruction (DPI) and participates in professional growth opportunities, such as county or state workshops, conferences, and/or advanced coursework at institutions of higher learning.

### Other Responsibilities:

1. Display competence and responsiveness to cultural differences present in both student and staff population.
2. Ensure the provision of quality services to students through participation in the agency's CQI process. Seeks opportunities to improve the academic program in relationship to their areas of expertise.
3. Actively participates and communicates with Eliada Academy team members on a consistent basis regarding academic strategies. Participates in scheduled teacher work days, all-staff agency meetings, as well as complying with all training requirements.
4. Develops appropriate educational field trips.
5. Ensure the safety of the students by providing consistent monitoring and supervision throughout the school.

### Reporting Relationship:

Position reports to: Eliada Academy Director

### Qualifications:

**Knowledge:** A Bachelor's Degree from an accredited college or university with an appropriate, current valid teaching certification as specified by the North Carolina Department of Public Instruction.

**Experience:** A minimum of two years teaching experience or direct residential experience with the target population is preferred.

**Skills/Working Conditions:** A valid North Carolina Driver's License and insurability by EHI's insurers is required. Work hours may include after hours, or weekend availability for trainings, all staff meetings. Must successfully complete pre-service workshop, including physical restraint training. Ability to easily and expeditiously climb and descend several flights of stairs, respond to a code, or call for staff assistance in the building or on campus. Position may experience verbal and/or physical aggression from the student population. Must provide a copy of current, valid teaching certificate at time of employment. Must maintain teaching certification by the North Carolina Department of Public Instruction and provide a copy of renewed teaching certificate to the principal upon completion of recertification requirements.

### Disclaimer Clause

Job descriptions are not intended, and should not be construed to be exhaustive lists of all responsibilities, skills, efforts or working conditions associated with this job. They are meant to be accurate reflections of the principle job elements essential for making fair pay decisions. This position description is not intended as a contract. A letter of employment confirms employment. North Carolina is an at-will employment state and Eliada is an at-will employer.

## Position Description

**Job Title:** Administrative Assistant  
**Department:** Eliada Academy  
**Status:** Non-Exempt

**Salary Grade:**

### Position Summary:

The Administrative Assistant works under the supervision of the Eliada Academy Director and provides administrative support to the Eliada Academy program and staff.

### Major Responsibilities:

1. Provide accurate and thorough administrative and clerical support for the Eliada Academy Director and staff. Includes timely correspondence, organized filing systems, scheduling, financial record keeping, uniform distribution and inventory maintenance, routine transportation problem-solving, ordering, inventories, daily/weekly/monthly and annual agency reports, audit preparations and other duties as requested. Maintains confidentiality of student, staff and program records and information.
2. Facilitate and maintain accurate and organized current and archived school records including those pertaining to but not limited to: attendance and academic progress; official transcripts (including documentation of admission and withdrawals); Special education records; Title I Grant Records; and maintaining all incident report documentation.
3. Deliver/administer medications for students as required by licensure. Maintain accurate medication records. Schedule medication evaluation appointments with the Medical Director and transcribe all medication evaluation notes.
4. Manage administrative office for Eliada Academy in a friendly, professional and organized manner. Includes telephone contacts, visitors, client appointments, and physical appearance of office space, staff requests and other inquiries.
5. Approval of service notes for billing, filing service notes, assisting in maintenance of all records for all audits, including but not limited to: Clinical and Team Minutes, MDT minutes, Incident Documentation, Enrollment Log, Travel Packs and other records as needed or required.

### Other Responsibilities:

1. Display competence and responsiveness to cultural differences present in both student and staff population
2. Ensure the provision of quality services to students through participation in the agency's CQI process
3. Perform other related administrative and programmatic tasks as assigned by the Eliada Academy Director.

### Reporting Relationship:

Position reports to: Eliada Academy Director

### Qualifications:

**Knowledge/Experience:** Must possess a High School Diploma or GED. Must have a working knowledge of word-processing, spreadsheet, and database software and be able to operate basic office equipment. Prefer at least one year experience in clerical service.

**Skills/Physical/Working Conditions:** Position requires professional communication skills, excellent organizational skills and the ability to multitask. Ability to easily and expeditiously climb and descend several flights of stairs, or call for staff assistance in the building or on campus. Must be able to work in a high pressure, high stress environment. Position may experience verbal and/or physical aggression from the student population.

### Disclaimer Clause:

Job descriptions are not intended, and should not be construed to be exhaustive lists of all responsibilities, skills, efforts, or working conditions associated with this job. They are meant to be accurate reflections of the principal job elements essential for making fair pay decisions. This position description is not intended as a contract. A letter of Employment confirms employment. North Carolina is an at-will employment and Eliada is an at-will employer.

Health referral agencies/programs, local churches, therapists in private practice, and parents/guardians of children served in the agencies treatment and child development programs. A variety of media will be utilized and may include local newspapers and magazines, flyers, email announcements, social media, yellow pages, and others. The demographics of the agencies current population served is reflective of the demographics of Buncombe county.

**The numbers in the following tables are projections, or estimates, and do not bind the State to fund the school at any particular level.**

*For the first two years the State will fund the school up to the maximum projected enrollment for each of those years approved in the projected enrollment tables. However, in subsequent years, the school may increase its enrollment only as permitted by G.S. 115C-238.29D(d), that is, an increase of 20% per year based on the previous year's enrollment. Any increase above 20% must be approved by the State Board of Education in accordance with G.S. 115C-238D(d).*

*In the following tables, please list for each year and grade level, the numbers of students that the school reasonably expects to enroll. In addition, please indicate any plans to increase the grade levels offered by the school over time and be sure these figures match those on the initial cover page. In describing your budgetary assumptions, explain the analysis utilized to project these specific enrollment figures. If your budget projections are lower than anticipated, how will the school adjust this budget and what is the determined break-even point for student enrollment?*

---

#### BUDGETARY ASSUMPTIONS

ENROLLMENT opening as grades 1-11 with 67 students

##### CLASS SIZE

- o 9 students per class max

##### STAFFING

- o Director - .75 FTE
- o Administrator .07133 FTE
- o 1 clerical staff
- o EC Teacher Opening with 1 F/T

##### CONTRACTED SERVICES

- o Financial/Audit/Legal 10050 for 1st year then 18050 each year afterwards
- o EC /Speech/Psychological 10050

OTHER OPERATING COSTS - based on historical trends of existing charters per ANS

analysis

*Also, in narrative format, explain how your spending priorities align with the school's mission, curricular offerings, transportation plans, and professional development needs. Be able to depict in chart format and discuss in a narrative how the school will maintain a small, contingency reserve and operate using sound fiscal practices. As you construct the budget, include any and all documentation about cash on hand, bonds, real estate, or grants as part of this application package.*

---

Eliada Academy will gain support from Eliada Foundation who has assets of \$12,000,000 and an endowment approaching \$3,000,000.





2 Compton Drive  
P.O. Box 16708  
Asheville, NC 28816

828-254-5356  
Fax: 828-259-5384  
www.eliada.org

Timothy A. Kelley  
*Chairman*

Hugh E. McCollum  
*Vice Chairman*

Martin Lewis  
*Secretary/Treasurer*

**MEMORANDUM**

To: The Board of Trustees  
Eliada Academy, Inc.

From: Eliada Foundation, Inc.  
Board of Directors  
Tim Kelley, Chairman of the Board

RE: Supplemental Funding for Eliada Academy

We are pleased to inform you that the Board of Directors of the Eliada Foundation has approved the request from Eliada Academy to provide supplemental funds sufficient to overcome any operating budget deficit through academic year 2017-2018. As a condition of this commitment, we request that the Treasurer of the Board of Directors of Eliada Academy be included in the budget planning process of Eliada Academy for each fiscal year and that Eliada Academy provide monthly financial statements to the Eliada Foundation showing results from operations.

This commitment is not a loan and in no way requires repayment or reimbursement.



The Symbol of Quality

COA

ACCREDITED

Council on Accreditation  
for Children and Family Services

**PROJECTED ENROLLMENT 2013-14 through 2017-2018**

IDENTIFY LEA FROM WHICH STUDENTS WILL PROBABLY COME

List LEA #1 – 110

List LEA #2 – 111

List LEA #3 – 440

Grade	2013-2014			2014-2015			2015-2016			2016-2017			2017-2018		
	LEA 1	LEA 2	LEA 3	LEA 1	LEA 2	LEA 3	LEA 1	LEA 2	LEA 3	LEA 1	LEA 2	LEA 3	LEA 1	LEA 2	LEA 3
Kindergarten	0	0	0	0	0	0	0	0	0	0	0	0	0	0	0
Grade 01	1	0	0	1	0	0	1	0	0	1	0	0	1	0	0
Grade 02	1	0	0	1	0	0	1	0	0	1	0	0	1	0	0
Grade 03	2	1	1	2	1	1	2	1	1	2	1	1	2	1	1
Grade 04	2	1	1	2	1	1	2	1	1	2	1	1	2	1	1
Grade 05	5	1	1	5	1	1	5	1	1	5	1	1	5	1	1
Grade 06	7	1	1	7	1	1	7	1	1	7	1	1	7	1	1
Grade 07	9	2	2	9	2	2	9	2	2	9	2	2	9	2	2
Grade 08	10	2	2	10	2	2	10	2	2	10	2	2	10	2	2
Grade 09	3	2	2	3	2	2	3	2	2	3	2	2	3	2	2
Grade 10	4	1	1	4	1	1	4	1	1	4	1	1	4	1	1
Grade 11	1	0	0	1	0	0	1	0	0	1	0	0	1	0	0
Grade 12	0	0	0	0	0	0	0	0	0	0	0	0	0	0	0
LEA Totals	45	11	11	45	11	11	45	11	11	45	11	11	45	11	11
<b>Overall Total Enrollment</b>	<b>67</b>														

**Budget: Revenue Projections 2013-14 through 2017-2018**

INCOME: REVENUE PROJECTIONS	2013-2014	2014-2015	2015-2016	2016-2017	2017-2018
--State ADM Funds	\$345,331	\$345,331	\$345,331	\$345,331	\$345,331
--Local Per Pupil Funds	\$121,806	\$121,806	\$121,806	\$121,806	\$121,806
--Federal Funds	\$0	\$0	\$0	\$0	\$0
--Grants*	\$0	\$0	\$0	\$0	\$0
--Foundations*	\$0	\$0	\$0	\$0	\$0
--Private Funds*	\$0	\$0	\$0	\$0	\$0
--Other Funds*	\$1,000	\$9,000	\$9,000	\$9,000	\$9,000
<b>TOTAL INCOME</b>	<b>\$468,137</b>	<b>\$476,137</b>	<b>\$476,137</b>	<b>\$476,137</b>	<b>\$476,137</b>

\*If you are depending on these sources of funding to balance your operating budget, please provide documentation, such as signed statements from donors, foundations, etc., on the availability of these funds.

**Budget (continued): Revenue Projections 2013-14 through 2017-2018**

**SHOW CALCULATIONS  
FOR FIGURING STATE  
AND LOCAL DOLLARS  
FOR THE PROPOSED  
CHARTER SCHOOL**

See <http://www.ncpublicschools.org/fbs/stats/index.html>

(OR Click on: Agency Website: Division of Financial Services, Reports and Statistics, Statistical Data

The formula for figuring these allotments can be found in the Resource Guide.

2011-2012 State ADM Allotments

LEA NAME	\$/ADM	\$/EC	HEADCOUNT*	% of Students from LEA
BUNCOMBE COUNTY	4,585.70	3,612.88		68.0%
ASHEVILLE CITY	4,745.74	3,649.02		16.0%
HAYWOOD COUNTY	4,655.32	3,262.78		16.0%
Weighted Average	4,622.45	3,562.65		100%

Local Per-Pupil Allotments-Charter School

LEA NAME	\$/Pupil	% of Students
BUNCOMBE COUNTY	1,852.68	68.0%
ASHEVILLE CITY	1,852.68	16.0%
HAYWOOD COUNTY	1,635.96	16.0%
Weighted Average	1,818.00	100%

**Budget (continued): Expenditure Projections 2013-14 through 2017-2018**

BUDGET EXPENDITURE PROJECTIONS	2013-2014	2014-2015	2015-2016	2016-2017	2017-2018
Personnel Total # Of Staff And Projected Costs	8 \$332,200	8 \$332,200	8 \$332,200	8 \$332,200	8 \$332,200
--Administrator(S) Resident/CEOs/OTI	1 \$10,700	0 \$10,700	0 \$10,700	0 \$10,700	0 \$10,700
--Clerical	6 \$25,000	1 \$25,000	1 \$25,000	1 \$25,000	1 \$25,000
--Teachers	6 \$216,000	6 \$216,000	6 \$216,000	6 \$216,000	6 \$216,000
--Librarians	0 \$0	0 \$0	0 \$0	0 \$0	0 \$0
--Guidance EC Teacher	1 \$37,000	1 \$37,000	1 \$37,000	1 \$37,000	1 \$37,000
--Teacher Assistants	0 \$0	0 \$0	0 \$0	0 \$0	0 \$0
--Custodian	0 \$0	0 \$0	0 \$0	0 \$0	0 \$0
--Maintenance	0 \$0	0 \$0	0 \$0	0 \$0	0 \$0
--Food Service	0 \$0	0 \$0	0 \$0	0 \$0	0 \$0
--Bus Driver	0 \$0	0 \$0	0 \$0	0 \$0	0 \$0
--Other Director	0 \$43,500	0 \$43,500	0 \$43,500	0 \$43,500	0 \$43,500
Employee Benefits	0 \$76,406	0 \$76,406	0 \$76,406	0 \$76,406	0 \$76,406
Staff Development	0 \$8,821	0 \$8,821	0 \$8,821	0 \$8,821	0 \$8,821
Materials And Supplies	0 \$10,000	0 \$10,000	0 \$10,000	0 \$10,000	0 \$10,000
Office Supplies	0 \$1,463	0 \$1,488	0 \$1,488	0 \$1,488	0 \$1,488
Instructional Equipment	0 \$350	0 \$350	0 \$350	0 \$350	0 \$350
Office Equipment	0 \$91	0 \$91	0 \$91	0 \$91	0 \$91
Testing Materials	0 \$1,675	0 \$1,675	0 \$1,675	0 \$1,675	0 \$1,675
Insurance	0 \$1,338	0 \$1,338	0 \$1,338	0 \$1,338	0 \$1,338
Utilities	0 \$4,502	0 \$4,502	0 \$4,502	0 \$4,502	0 \$4,502
Rent	0 \$9,650	0 \$9,650	0 \$9,650	0 \$9,650	0 \$9,650
Maintenance & Repair	0 \$1,200	0 \$1,200	0 \$1,200	0 \$1,200	0 \$1,200
Transportation	0 \$0	0 \$0	0 \$0	0 \$0	0 \$0
Marketing	0 \$0	0 \$0	0 \$0	0 \$0	0 \$0
Food/Cafeteria Supplies	0 \$0	0 \$0	0 \$0	0 \$0	0 \$0
Professional Development/ Contracted Services	0 \$20,100	0 \$28,100	0 \$28,100	0 \$28,100	0 \$28,100

BUDGET EXPENDITURE PROJECTIONS	2013-2014	2014-2015	2015-2016	2016-2017	2017-2018
TOTALS	8.00 \$467,796	8.00 \$475,821	8.00 \$475,821	8.00 \$475,821	8.00 \$475,821

**Budget (continued): Expenditure Projections 2013-14 through 2017-2018**

**BUDGET NARRATIVE:**

*Please include additional information that showcases all assumptions for your budgetary calculations. For instance, you may start the first year with 10 teachers but plan to add 2 teachers each year. The increase may be seen in the budget; however, the specific assumptions are missing beyond the projected first year. Use this space to explain, in depth, your budget calculations for years 2 through 5.*

---

	2013-2014	2014-2015	2015-2016	2016-2017	2017-2018
Projected Contingency					
Total Revenue	\$468,137	\$476,137	\$476,137	\$476,137	\$476,137
Total Expenditures	\$467,796	\$475,821	\$475,821	\$475,821	\$475,821
Projected Surplus/Shortfall	\$341	\$316	\$316	\$316	\$316
Carryover-Prior year	0	\$341	\$657	\$973	\$1,289
Contingency /Fund Balance Appropriated	\$341	\$657	\$973	\$1,289	\$1,605

**WORKING CAPITAL and/or ASSETS ON DATE OF APPLICATION**

<i>Cash on Hand</i>	<u>\$\$</u> .00
<i>Certificates of Deposit</i>	<u>\$\$</u> .00
<i>Bonds</i>	<u>\$\$</u> .00
<i>Real Estate</i>	<u>\$\$</u> .00
<i>Capital Equipment</i>	<u>\$\$</u> .00
<i>Motor Vehicles</i>	<u>\$\$</u> .00
<i>Other Assets</i>	<u>\$\$</u> .00
<b>TOTAL</b>	<u>\$\$</u> .00

**ADDITIONAL NOTES:**

See Financial Statements Download

**SCHOOL AUDITS:**

**PROGRAM AUDITS: GS 115C-238.29B(b)(6)**

*Describe the procedure and method for evaluating the overall effectiveness of the proposed charter school program as related to the mission of the school.*

---

Eliada Academy will utilize multiple resources to evaluate the charter school program. Data on student demographics; critical incidents; pre and post academic and clinical/behavioral progress; and discharge placements will be collected/administered to all students with input from their guardians/parents and Academy staff. The data will be aggregated annually and reviewed formally through a program evaluation/quality improvement model. Other data collected and reviewed will include student and parent satisfaction surveys; student exit interviews; staff surveys; EOG and EOC test scores; licensure reviews; Mental Health audits; and others. Quarterly quality improvement meetings will focus on review of the evaluation data and reports, and the School Improvement Plan. Academy staff will revise and set new goals and objectives to ensure quality delivery of services. An annual report will be presented to the Eliada Academy Board. In addition, longitudinal surveys will be implemented at 3, 6, 12 month, and annual intervals after discharge to collect data on each student's ongoing well being after

leaving Eliada Academy.

See Program Audit Download

**FINANCIAL AUDITS:** GS 115C-238.29F(f)(1)

*Describe the procedure and method for conducting an independent financial audit for the proposed charter school. Give the name of the firm approved by the NC Local Government Commission (GCC) that will conduct the audit. Include the complete mailing address, telephone number and fax number.*

---

See Letter from Auditor Download

**CIVIL LIABILITY AND INSURANCE** (GS 115C-238.29F(c))

*State the proposed coverage for:*

Comprehensive General Liability	\$3,000,000
Officers and Directors/Errors and Omissions	\$3,000,000
Property Insurance	\$2,500,000
Motor Vehicle Liability	\$1,000,000
Bonding	\$0
Minimum amount:	\$250,000
Maximum amount:	\$250,000
Other	General Aggregate \$3,000,000
Professional Liability	\$3,000,000
Employment Practices Liability	\$3,000,000
Fiduciary Liability	\$3,000,000

If you, as an applicant, have already received quote from an insurance organization, please provide a copy within the appendices.

See Insurance Quote Download

See Resource Manual for Minimums allowed by SBE Policy.

**TRANSPORTATION** (G.S. 115C-238.29F(h))

*Describe in detail the transportation plan that will ensure that no child is denied access to the school due to lack of transportation.*

---

Residential students will attend Eliada Academy on the campus in which they reside. To ensure that



transportation is not a barrier for day students, Eliada Academy staff will actively assist parents in finding transportation options. Carpooling and other options will be encouraged.

**FACILITY** (GS 115C-238.29D(c))

*Describe the facility in which the school will be located. Include information on how the site is appropriate to your instructional program. Note that the SBE may approve a charter school prior to the school's obtaining a facility; however, students may not attend school and no funds will be allocated until the school has obtained a facility and has provided a valid Certificate of Occupancy for Educational use to The Office of Charter Schools.*

Eliada Academy will be located in six (6) existing buildings, a four story school building and the central classroom areas of five (5) residential cottages. Eliada Academy will seek valid Certificate of Occupancy for Educational use for each of these buildings. All six buildings are currently zoned and licensed by the Department of Health Services Regulation for Day Treatment or Psychiatric Residential Treatment Facility.

**See Floor plans, photos, etc of the facility Download**

Name of the facility (if known): Eliada Academy  
Address: 2 Compton Drive  
City/State/Zip: Asheville NC 28806

Description of the Facility:

Total square feet:	<u>14,727</u>
Number of Classrooms:	<u>10</u>
Number of Restrooms:	<u>11</u>
Other Rooms:	<u>E</u>
Auditorium:	
Gymnasium:	<u>Gymnasium 4,712 Total square feet</u>
Fitness Center:	<u>4,068 Total square feet</u>
Music Room:	
Art Room:	
Laboratory:	

Ownership:  Fee Simple or  Lease

If the facility is to be leased, provide the following information:

- (a) Term of the Lease: NA
- (b) Type of Lease: NA
- (c) Rent: \$ 9,650 per year ~~per month~~

Name of Landlord: Eliada Foundation, Inc.  
Address: 2 Compton Drive  
City/State/Zip: Asheville NC 28806  
Phone: 828-254-5356 Fax: 828-259-5384

Document inspections for the following:

- (a) Fire: See Fire Inspection Download
- (b) Safety: See Safety Inspection Download
- (c) Handicapped accessibility? See Handicapped Accessibility Download

Describe how the maintenance will be provided for the facility.

---

Routine maintenance and cleaning will be provided by the agency's maintenance department.

# CUMMINGS, CENTER

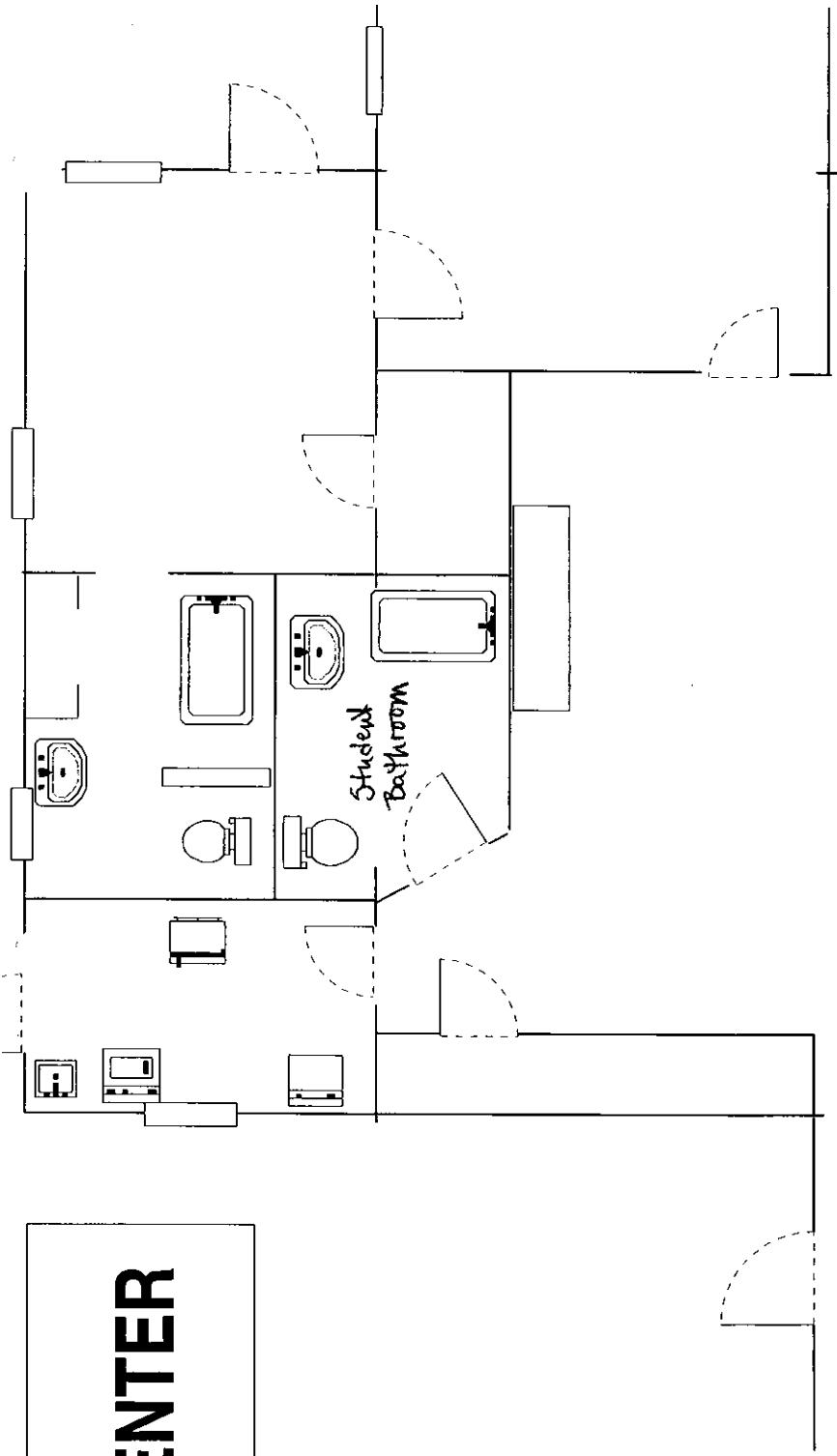

Classroom  
21'7" x 40'

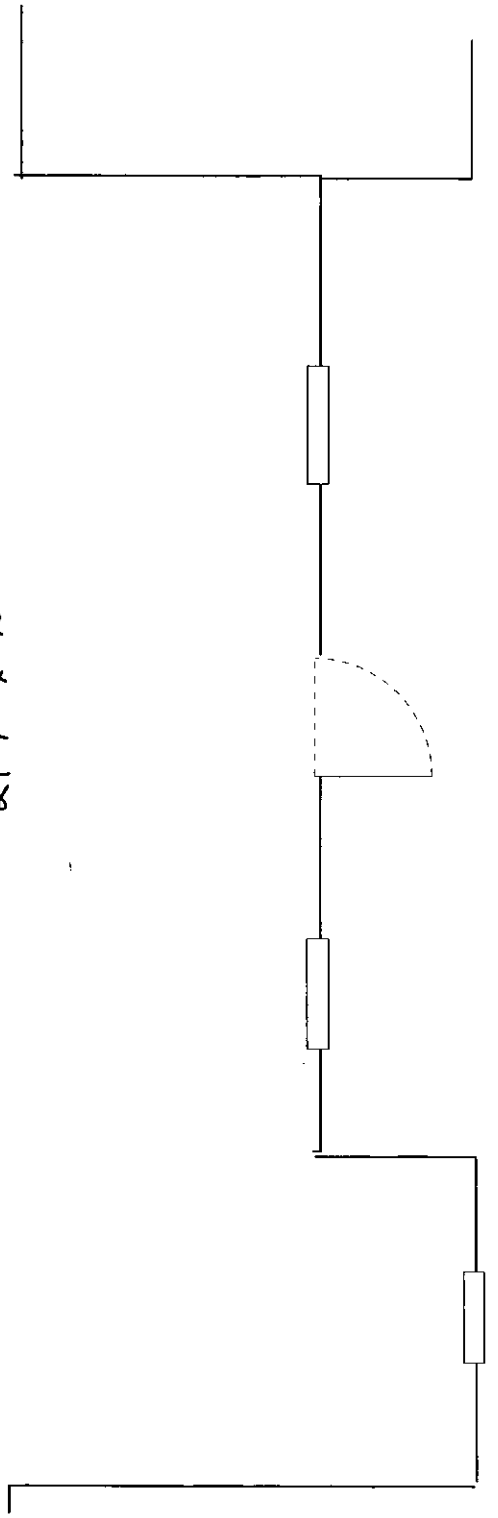

# REYNOLDS, CENTER

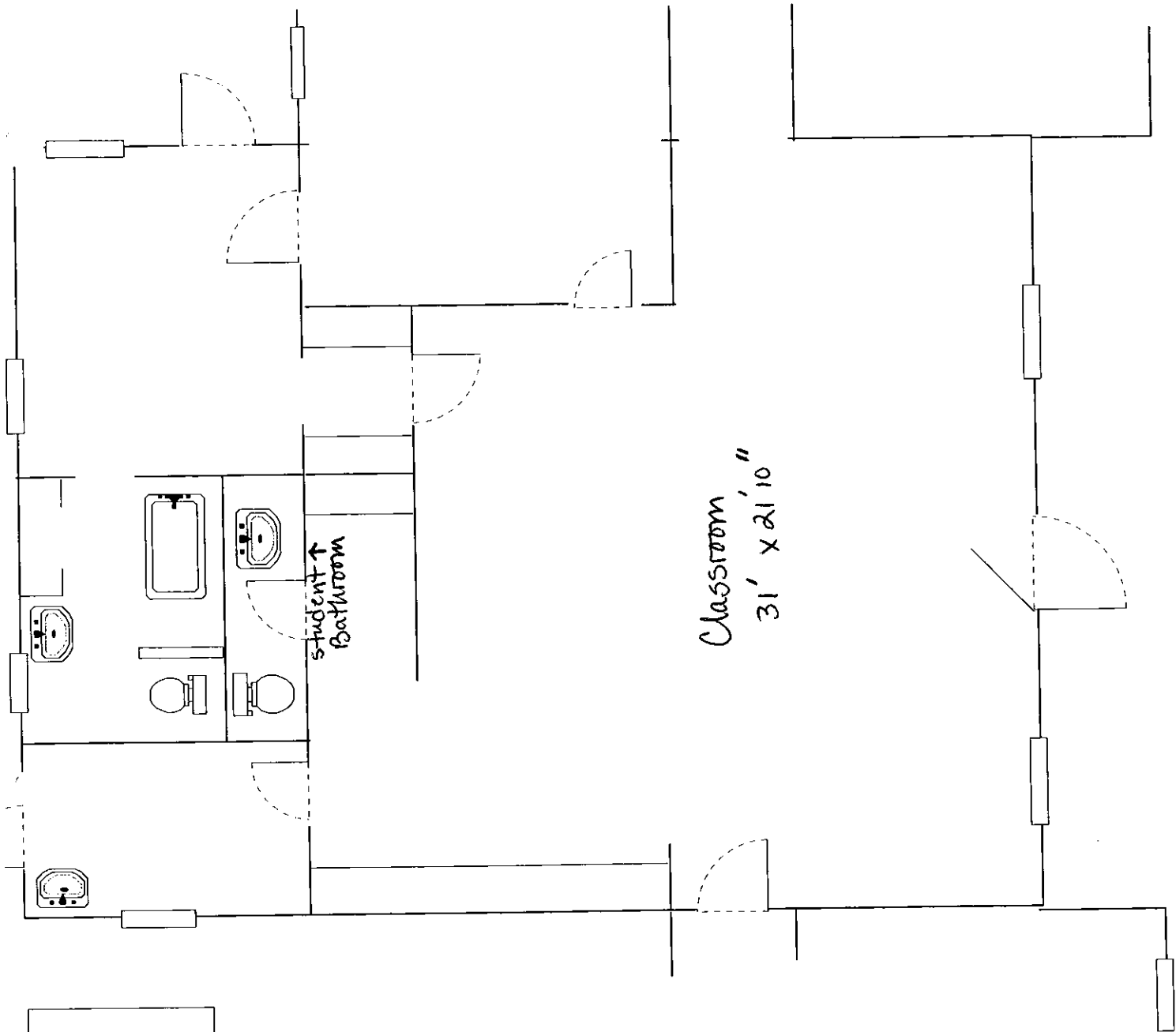

# LIONS, CENTER

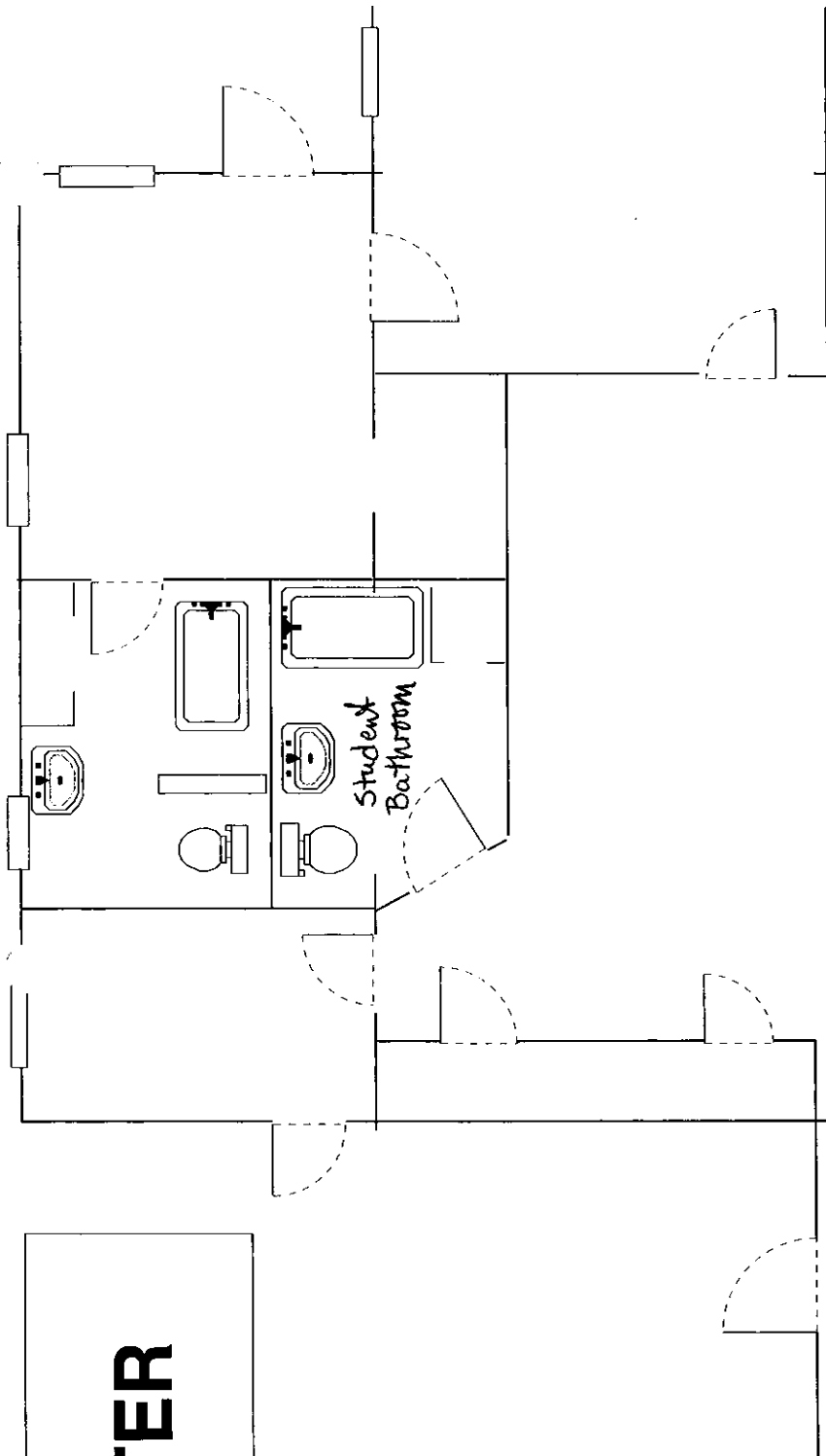

Classroom  
24'10" x 39'7"

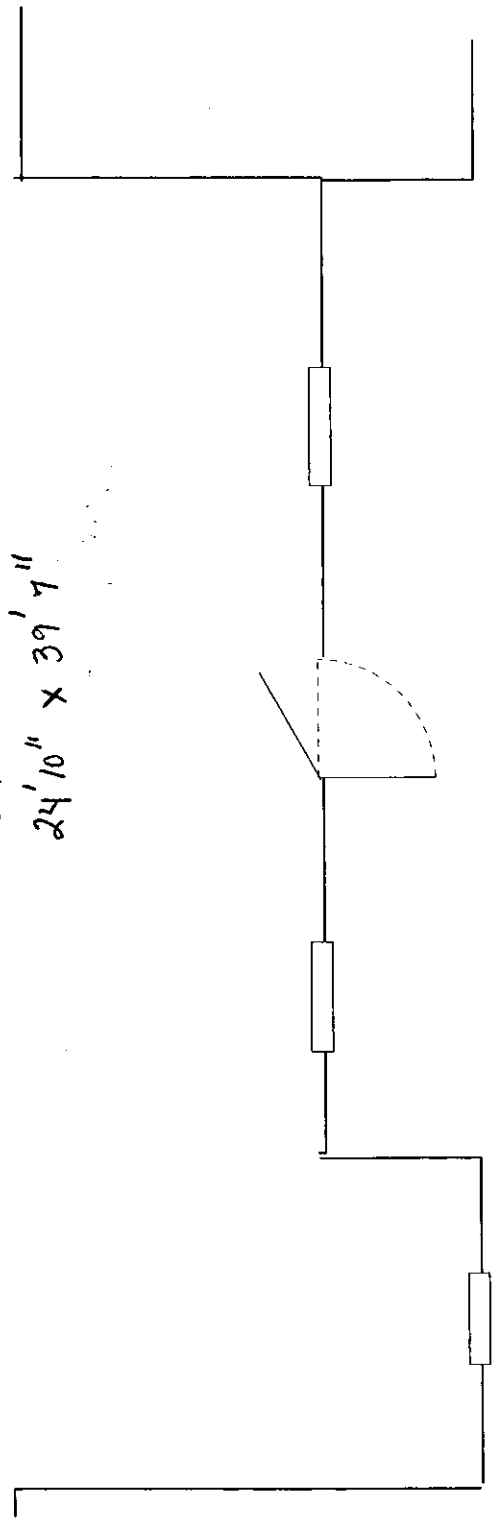

# REUTER, CENTER

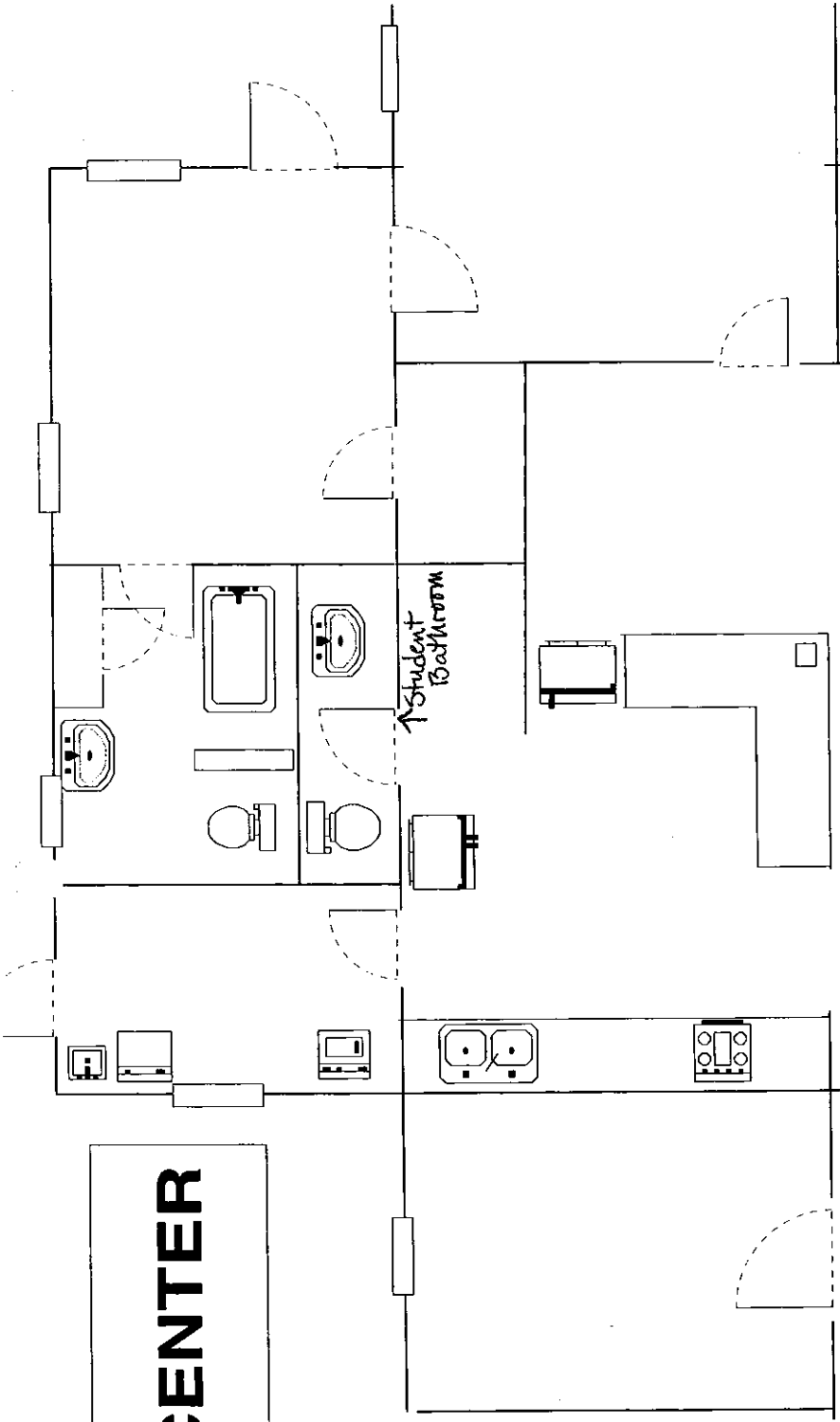

Classroom  
40' x 24' 8"

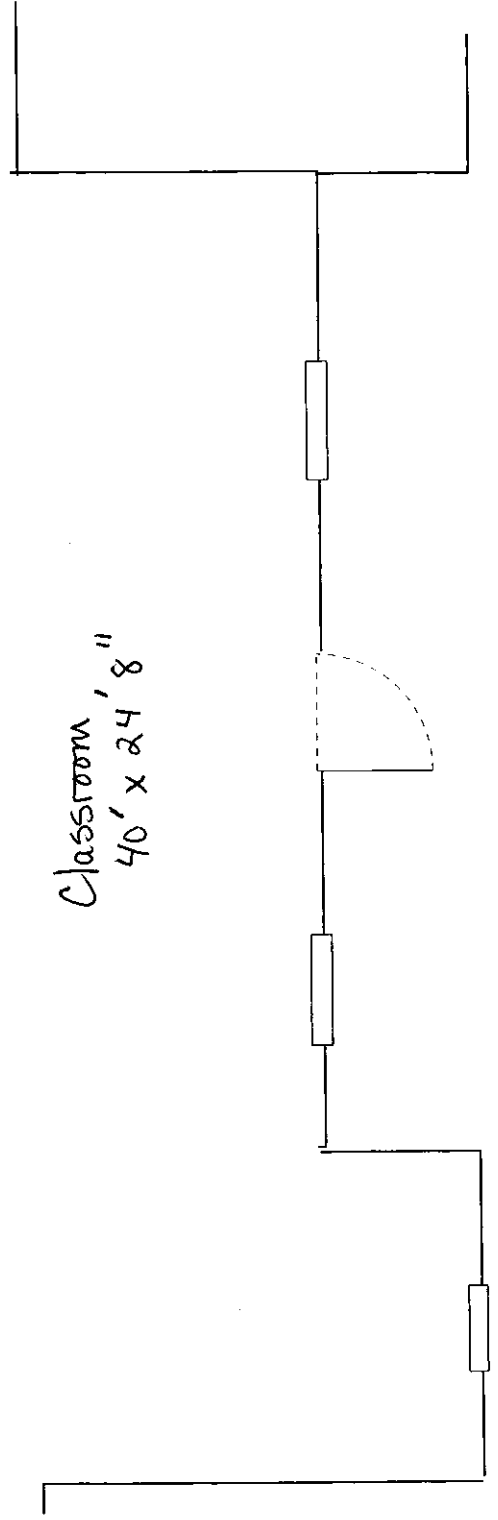

Earle, Center

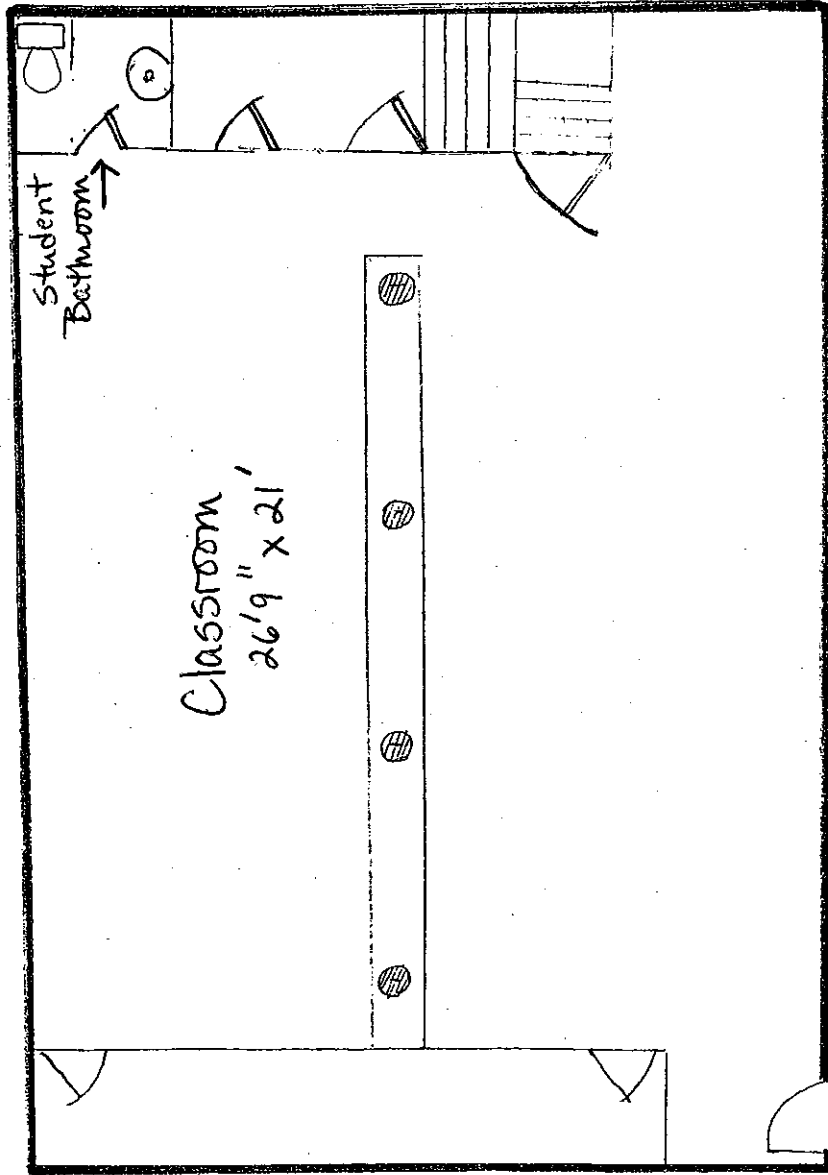

**ALLRED  
BASEMENT**

Total Square Feet 11,648

# Classrooms - 5

# Bathrooms - 6

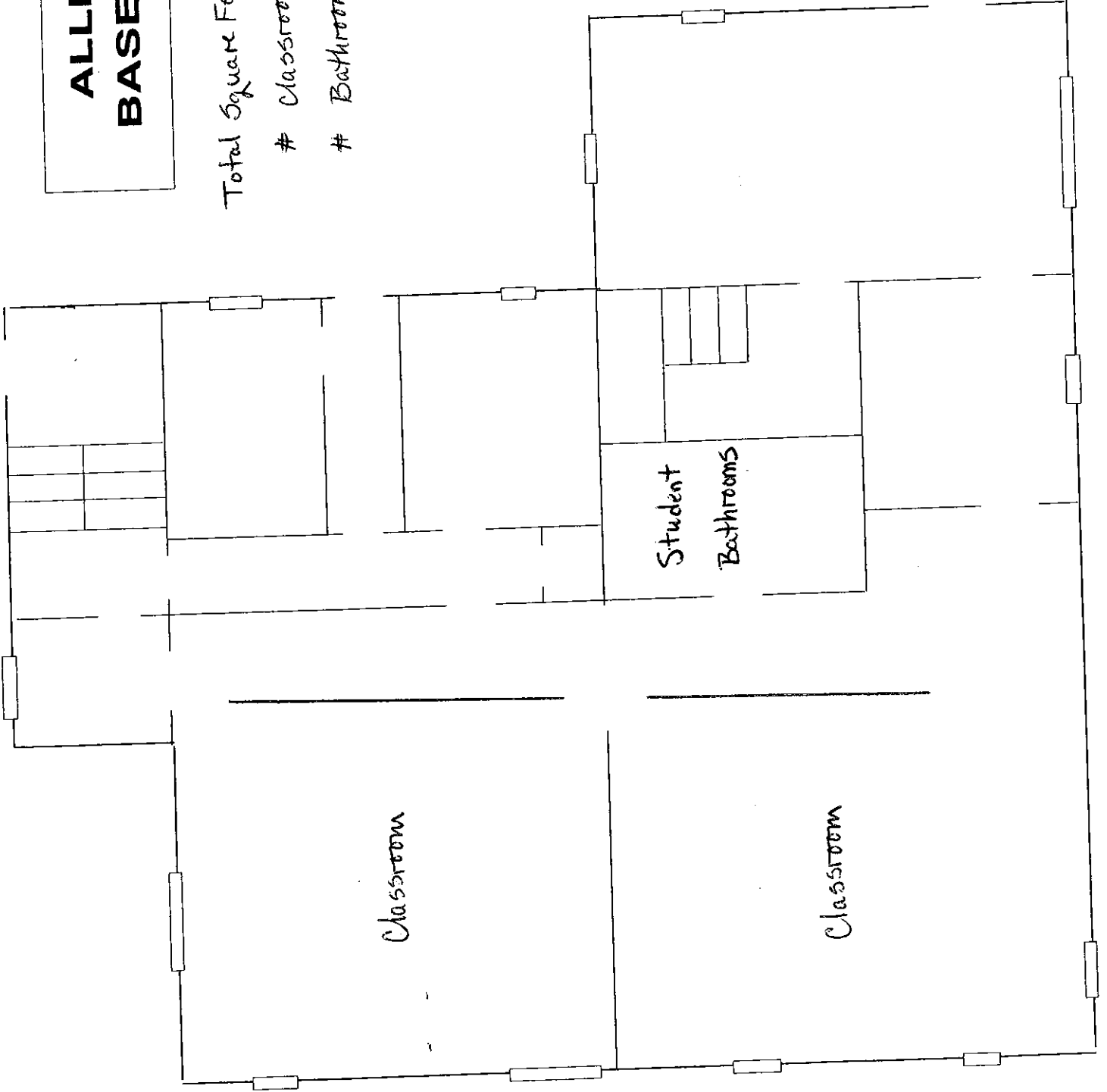

**ALLRED  
FIRST FLOOR**

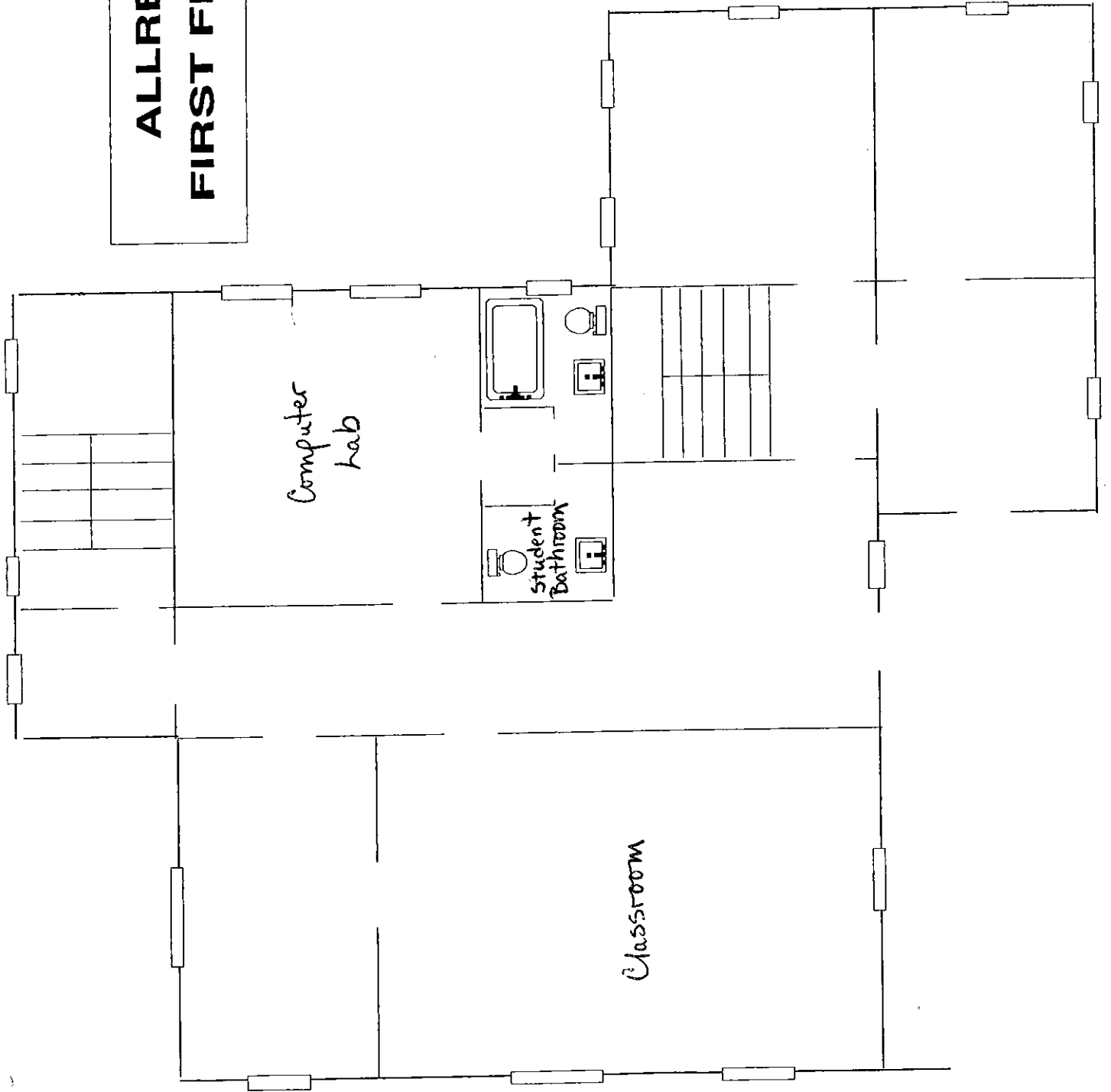



**ALLRED  
SECOND FLOOR**

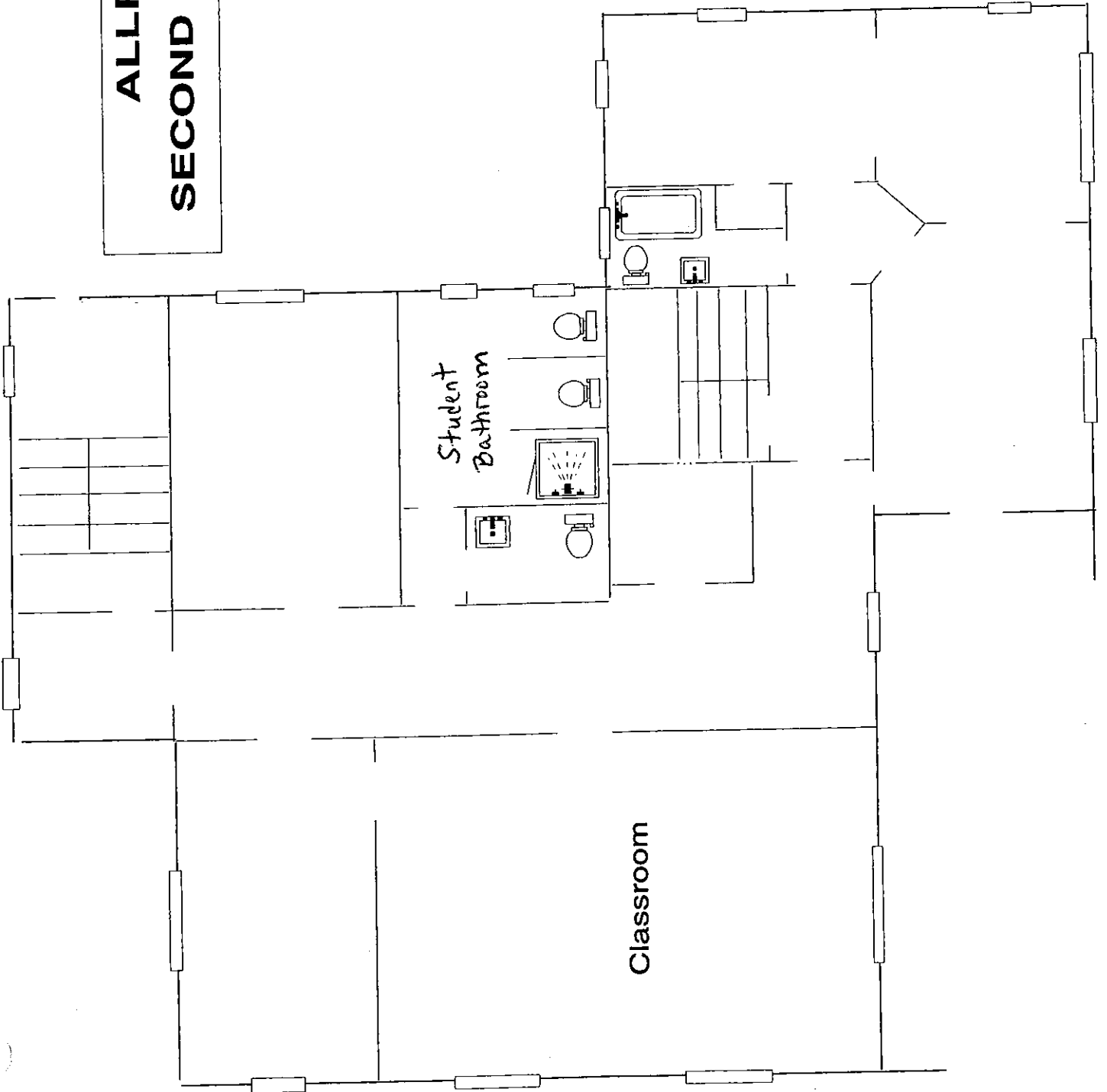

**ALLRED  
THIRD FLOOR**

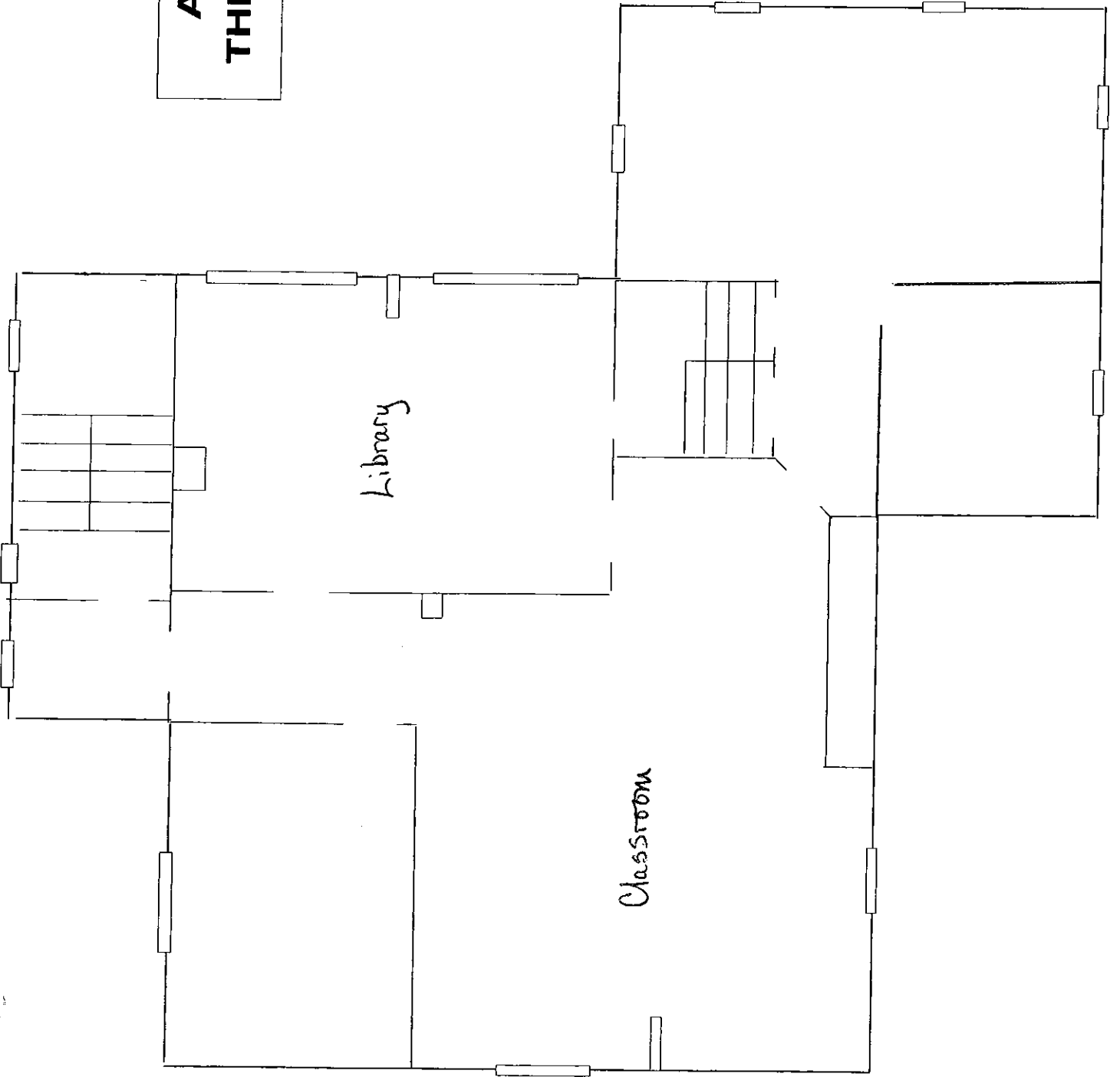

**REPORT OF INSPECTION FIRE MARSHAL'S OFFICE  
CITY OF ASHEVILLE**

**\*\*THIS IS NOT AN INVOICE, THE ASHEVILLE FINANCE DEPARTMENT WILL MAIL YOU AN INVOICE**

Rating as: EMERGENCY HOME - ACADEMY (ALL RED) Date: 2/20/12  
Street Address: 57 CAMPBELL DR. Zip: 28304 Phone: 254-5396  
Billing Address: \_\_\_\_\_ Zip: \_\_\_\_\_ Phone: \_\_\_\_\_  
Contact: \_\_\_\_\_ Phone: \_\_\_\_\_  
Notes: \*REINSPECTION\*

ALL VIOLATIONS ARE CLEAR AT THIS TIME

City Ordinances and N.C. General Statutes charge the Fire Official with the responsibility of protecting the people and properties from the ravages of fire. This is accomplished by an organized program of inspections, and enforcement of Codes, Statutes, and Standards intended to minimize the community's fire loss. Should there be any questions as to the validity of this inspection, we invite you to call 828-259-5640, or mail correspondence to the Asheville Fire & Rescue Department, Fire Marshal's Office, P.O. Box 7148, Asheville, N.C. 28802.

**THIS IS VERY IMPORTANT!**

The fire code violations found, as listed above, must be corrected on or before N/A. Failure to correct these violations will result in a re-inspection fee of \$ N/A. Maintaining these violations can also result in civil penalties. If difficulties arise and a request for an extension is necessary, contact the Fire Code Official as listed below.

I understand the terms and conditions of this report:

Signed: Kyle Barrett  
Printed: Kyle Barrett

Fire Official/Phone: 259-51050  
Signed: [Signature]  
Printed: TRE HILL

Reinspection # \_\_\_\_\_ Previous Date: \_\_\_\_\_ FEE \$ N/A

REPORT OF INSPECTION FIRE MARSHAL'S OFFICE  
CITY OF ASHEVILLE

\*\*THIS IS NOT AN INVOICE, THE ASHEVILLE FINANCE DEPARTMENT WILL MAIL YOU AN INVOICE.

Operating As: Florida Home - Craminos Date: 1/2/10  
Street Address: 555 Florida Home Rd Zip: 28906 Phone: 252-5551  
Billing Address: \_\_\_\_\_ Zip: \_\_\_\_\_ Phone: \_\_\_\_\_  
Contact: Lynn Bassett Phone: 778-3434  
Notes: no

No Violations At This Time

[Signature]

City Ordinances and N C General Statutes charge the Fire Official with the responsibility of protecting the people and properties from the ravages of fire. This is accomplished by an organized program of inspections, and enforcement of Codes, Statutes, and Standards intended to minimize the community's fire loss. Should there be any questions as to the validity of this inspection, we invite you to call 828-259-5640, or mail correspondence to the Asheville Fire & Rescue Department, Fire Marshal's Office, P.O. Box 7148, Asheville, N.C. 28802.

**THIS IS VERY IMPORTANT!**

The fire code violations found, as listed above, must be corrected on or before \_\_\_\_\_. Failure to correct these violations will result in a re-inspection fee of \$ \_\_\_\_\_. Maintaining these violations can also result in civil penalties. If difficulties arise and a request for an extension is necessary, contact the Fire Code Official as listed below.

I understand the terms and conditions of this report:

Fire Official/Phone: 252-5650

Signed: [Signature]

Signed: [Signature]

Printed: [Name]

Printed: [Name]

Reinspection # \_\_\_\_\_ Previous Date: \_\_\_\_\_ FEE \$ \_\_\_\_\_

REPORT OF INSPECTION FIRE MARSHAL'S OFFICE  
CITY OF ASHEVILLE

\*\*THIS IS NOT AN INVOICE, THE ASHEVILLE FINANCE DEPARTMENT WILL MAIL YOU AN INVOICE.

Operating As: ELIZABETH HOME - RENTER Date: 1/5/12  
Street Address: 111 CHERRY DR Zip: 28906 Phone: 252-5350  
Billing Address: \_\_\_\_\_ Zip: \_\_\_\_\_ Phone: \_\_\_\_\_  
Contact: KYLE BARRETT Phone: 775-3434  
Notes: 6- (1)

No Violations At This Time. EJA

City Ordinances and N C General Statutes charge the Fire Official with the responsibility of protecting the people and properties from the ravages of fire. This is accomplished by an organized program of inspections, and enforcement of Codes, Statutes, and Standards intended to minimize the community's fire loss. Should there be any questions as to the validity of this inspection, we invite you to call 828-259-5640, or mail correspondence to the Asheville Fire & Rescue Department, Fire Marshal's Office, P.O. Box 7148, Asheville, N.C. 28802.

**THIS IS VERY IMPORTANT!**

The fire code violations found, as listed above, must be corrected on or before \_\_\_\_\_. Failure to correct these violations will result in a re-inspection fee of \$ \_\_\_\_\_. Maintaining these violations can also result in civil penalties. If difficulties arise and a request for an extension is necessary, contact the Fire Code Official as listed below.

I understand the terms and conditions of this report:

Fire Official/Phone: 252-5650

Signed: [Signature]

Signed: [Signature]

Printed: Kyle Barrett

Printed: TEE ALLEN

Reinspection # \_\_\_\_\_ Previous Date: \_\_\_\_\_ FEE \$ \_\_\_\_\_

**REPORT OF INSPECTION FIRE MARSHAL'S OFFICE  
CITY OF ASHEVILLE**

**\*\*THIS IS NOT AN INVOICE, THE ASHEVILLE FINANCE DEPARTMENT WILL MAIL YOU AN INVOICE**

Rating as: FLANDA HOME - FABLE COTTAGE Date: 2/14/16  
Street Address: 205 FLANDA HOME RD Zip: 28806 Phone: 828-535-4600  
Billing Address: \_\_\_\_\_ Zip: \_\_\_\_\_ Phone: \_\_\_\_\_  
Contact: \_\_\_\_\_ Phone: \_\_\_\_\_  
Notes: \*REINSPECTION\*

ALL VIOLATIONS ARE CLEAR AT THIS TIME.

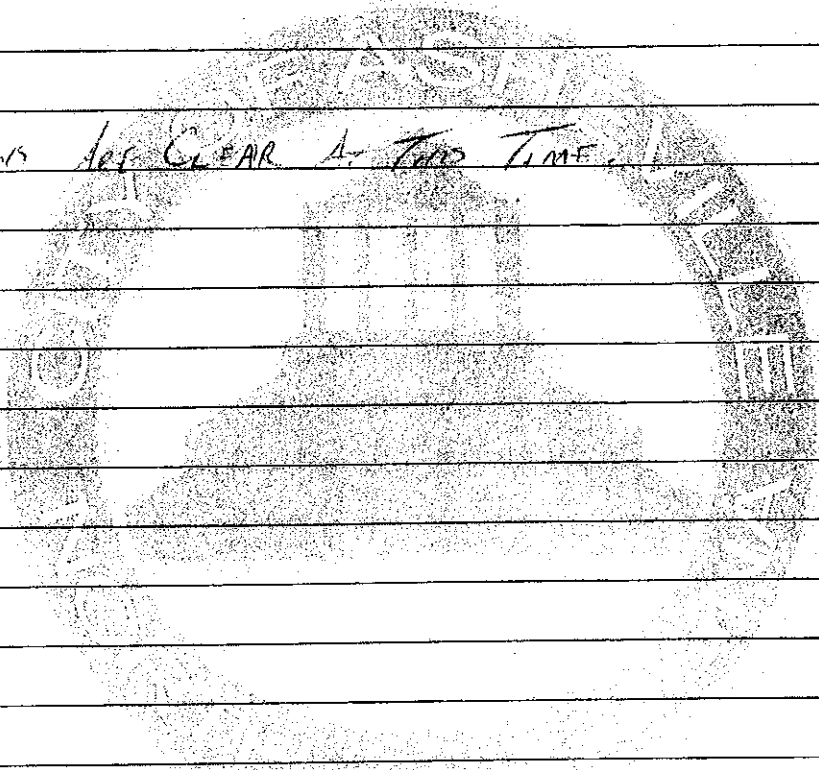

City Ordinances and N.C. General Statutes charge the Fire Official with the responsibility of protecting the people and properties from the ravages of fire. This is accomplished by an organized program of inspections, and enforcement of Codes, Statutes, and Standards intended to minimize the community's fire loss. Should there be any questions as to the validity of this inspection, we invite you to call 828-259-5640, or mail correspondence to the Asheville Fire & Rescue Department, Fire Marshal's Office, P.O. Box 7148, Asheville, N.C. 28802.

**THIS IS VERY IMPORTANT!**

The fire code violations found, as listed above, must be corrected on or before n/a. Failure to correct these violations will result in a re-inspection fee of \$ n/a. Maintaining these violations can also result in civil penalties. If difficulties arise and a request for an extension is necessary, contact the Fire Code Official as listed below.

I understand the terms and conditions of this report:  
Signed: [Signature]  
Printed: Kyle Barrett

Fire Official/Phone: 259-5680  
Signed: [Signature]  
Printed: Tom Alford

Reinspection # \_\_\_\_\_ Previous Date: \_\_\_\_\_ FEE \$ n/a  
White Copy = Fire Official Yellow Copy = Customer Page \_\_\_\_\_ of \_\_\_\_\_

REPORT OF INSPECTION FIRE MARSHAL'S OFFICE  
CITY OF ASHEVILLE

\*\*THIS IS NOT AN INVOICE, THE ASHEVILLE FINANCE DEPARTMENT WILL MAIL YOU AN INVOICE

Rating as: ELIADA HOME - LIONS Date: 2/20/10  
Street Address: 53 COLLETON DR. Zip: 28806 Phone: 54-5330  
Billing Address: \_\_\_\_\_ Zip: \_\_\_\_\_ Phone: \_\_\_\_\_  
Contact: \_\_\_\_\_ Phone: \_\_\_\_\_  
Notes: \*REINSPECTION\*

VIOLATIONS CLEARED AT THIS TIME.

City Ordinances and N C General Statutes charge the Fire Official with the responsibility of protecting the people and properties from the ravages of fire. This is accomplished by an organized program of inspections, and enforcement of Codes, Statues, and Standards intended to minimize the community's fire loss. Should there be any questions as to the validity of this inspection, we invite you to call 828-259-5640, or mail correspondence to the Asheville Fire & Rescue Department, Fire Marshal's Office, P.O. Box 7148, Asheville, N.C. 28802.

**THIS IS VERY IMPORTANT!**

The fire code violations found, as listed above, must be corrected on or before 2/21. Failure to correct these violations will result in a re-inspection fee of \$ 100. Maintaining these violations can also result in civil penalties. If difficulties arise and a request for an extension is necessary, contact the Fire Code Official as listed below.

I understand the terms and conditions of this report:  
Signed: [Signature]  
Printed: Kyle Barrett

Fire Official/Phone: 259-5650  
Signed: [Signature]  
Printed: Tom A...

Reinspection # \_\_\_\_\_ Previous Date: \_\_\_\_\_ FEE \$ 100  
White Copy = Fire Official Yellow Copy = Customer Page \_\_\_\_\_ of \_\_\_\_\_

REPORT OF INSPECTION FIRE MARSHAL'S OFFICE  
CITY OF ASHEVILLE

\*\*THIS IS NOT AN INVOICE, THE ASHEVILLE FINANCE DEPARTMENT WILL MAIL YOU AN INVOICE.

Operating As: ELIADA HOME - REYNOLDS Date: 1-1-10

Street Address: 844 ELIADA HOME RD Zip: 28901 Phone: 252-5556

Billing Address: \_\_\_\_\_ Zip: \_\_\_\_\_ Phone: \_\_\_\_\_

Contact: \_\_\_\_\_ Phone: \_\_\_\_\_

Notes: \*REMOVED TEXT\*

ALL VIOLATIONS ARE CLEAR AT THIS TIME.

City Ordinances and N C General Statutes charge the Fire Official with the responsibility of protecting the people and properties from the ravages of fire. This is accomplished by an organized program of inspections, and enforcement of Codes, Statutes, and Standards intended to minimize the community's fire loss. Should there be any questions as to the validity of this inspection, we invite you to call 828-259-5640, or mail correspondence to the Asheville Fire & Rescue Department, Fire Marshal's Office, P.O. Box 7148, Asheville, N.C. 28802.

**THIS IS VERY IMPORTANT!**

The fire code violations found, as listed above, must be corrected on or before 1/1/10. Failure to correct these violations will result in a re-inspection fee of \$ 100. Maintaining these violations can also result in civil penalties. If difficulties arise and a request for an extension is necessary, contact the Fire Code Official as listed below.

I understand the terms and conditions of this report:

Fire Official/Phone: 252-5556

Signed: Kyle Barrett

Signed: \_\_\_\_\_

Printed: Kyle Barrett

Printed: Kyle Barrett

Reinspection # \_\_\_\_\_

Previous Date: \_\_\_\_\_

FEE \$ 100



**INSPECTION OF SCHOOL**

Score: 91.5  
Date of Insp/Chg: 04/10/2012  
Status Code: A

Health Department: BUNCOMBE  
Current ID Number: 01011440018  
Old ID Number:

<b>Water Supply</b>	<input checked="" type="checkbox"/> Community	<input type="checkbox"/> Non-Transient Non-Community	<b>Water sample taken?</b> <input type="checkbox"/> Yes <input checked="" type="checkbox"/> No
	<input type="checkbox"/> Transient Non-Community	<input type="checkbox"/> Non-Public Water Supply	<input checked="" type="checkbox"/> Inspection
			<input type="checkbox"/> Name Change
<b>Wastewater</b>	<input checked="" type="checkbox"/> Community	<input type="checkbox"/> On-Site System	<input type="checkbox"/> Visit
		<b>Seating:0</b>	<input type="checkbox"/> Status Change
			<input type="checkbox"/> Re-Inspection
			<input type="checkbox"/> Verification of Closure

Name of School: ELIADA ACADEMY

Location: 2 COMPTON DR

City: ASHEVILLE

State: NC

Zip: 28806

Mailing Addr: 2 COMPTON DR

City: ASHEVILLE

State: NC

Zip: 28806

	SCORE	SCHOOL [.2408]
1. WATER SUPPLY: Approved water supply properly located, constructed and operated, adequate for all requirements 130* ; well house clean, no storage 15* ; no cross connections 30* (.2405)	175	4. Replace toilet seats when they are no longer smooth and easily cleanable.
2. SANITARY SEWAGE DISPOSAL: Sewage collected, treated, and disposed of by an approved method 150* ; system properly operated and maintained 55* (.2407)	205	6. Repair damaged walls and baseboards
3. DRINKING FOUNTAINS: Clean and in good repair #40 ; adequate pressure, properly regulated 40# (.2406)	80	8. Clean A/C filters. Replace missing window screens
4. TOILET FACILITIES: Walls and ceilings clean, nonabsorbent, washable, and in good repair 30# ; fixtures clean and in good repair (40#) ; floors impervious, kept clean 30# (.2408)	100	11. Products labeled "keep out of reach of children" (EXPO solution) must be stored 5' off the floor.
5. LAVATORY FACILITIES: Fixtures clean and in good repair 30# ; soap and individual towels or approved hand-drying devices provided 40# (.2409)	70	
6. FLOORS: WALLS: AND CEILINGS: Floors, walls, and ceilings clean and in good repair (30#) (.2410)	30	
7. STORAGE SPACES: Clean 20# ; storage off floor 20# (.2411)	40	
8. LIGHTING AND VENTILATION: Fixtures, grills, vents, blinds, drapes, etc., clean and in good repair (40#) (.2412)	40	
9. DRESSING ROOMS AND SHOWERS: Floors, walls, and ceilings clean, in good repair, washable, non-absorbent 30# ; fixtures clean, in good repair 40# ; facilities for storage of clothes provided, kept clean 20# ; soap and towel 10* (.2413)	100	
10. SOLID WASTE DISPOSAL: Impervious, cleanable containers with lids, approved type 20* ; clean and in good repair 20# ; empties as needed; properly disposed of 40# (.2414)	80	
11. PREMISES: MISCELLANEOUS: Premises neat, clean 30# ; no vector breeding or harborage 20# ; pesticides and other toxic materials properly handled and stored (30*) (.2415)	80	
<b>TOTAL</b>	<b>1000</b>	<b>85</b>

Additional Comment Sheet Attached  
 YES  NO

EHS ID#: 2064

Inspection By: Crystal Buckner  
DENR 1163 (Revised 6/03)  
Environmental Health Services Section (Review 6/06)

*Crystal M. Buckner REHS*

NC Department of Environmental and Natural Resources  
 Division of Environmental Health  
**INSPECTION OF  
 RESIDENTIAL CARE FACILITY**  
 (For facilities, as defined, with  
 not more than 12 residents)

Demerit Score: 0  
 Date of Insp/Chg: 05/13/2011  
 Status Code: A

Health Department: BUNCOMBE  
 Current Facility ID: 01011430396  
 Old Facility ID:

Water Supply	<input checked="" type="checkbox"/> Community <input type="checkbox"/> Transient Non-Community	Non-Transient Non-Community Non-Public Water Supply	Water sample taken? <input checked="" type="checkbox"/> Inspection Visit	Yes <input checked="" type="checkbox"/> No <input checked="" type="checkbox"/> Name Change Status Change
Wastewater	<input checked="" type="checkbox"/> Community	On-Site System	Re-Inspection	Verification of Closure

Name of Establishment: ELIDA HOME ( EARLE COTTAGE )  
 Location Address: 2 COMPTON DR

Permittee: ELIADA HOME  
 Number of Residents: 6  
 Mailing Addr: P.O. BOX 16708

City: ASHEVILLE State: NC Zip: 28806

City: ASHEVILLE State: NC Zip: 28816

Approved (20 or less demerits, and no 6-point deductions)  
 Provisional (More than 20, but 40 or less demerits, or a 6-point demerit)

Family Foster Home (Only items 1 and 2 apply)  
 Disapproved (More than 40 demerits or failure to improve provisional classification)  
 Demerits COMMENTS

- 1 WATER SUPPLY: Public supply; private supply approved 6 ( )
- 2 LIQUID WASTES: Sewage and other liquid wastes disposed of by approved method 6 ( )
- 3 FOOD SUPPLIES AND PROTECTION: Supplies: All food clean, wholesome, no spoilage 6; Protection: Adequate during storage, preparation and serving, potentially hazardous food 45° F or below, or 140° F or above 5; all refrigerators with thermometers 2; pork, ground beef products, poultry and stuffings, etc., thoroughly cooked; meat and poultry salad, potato salad, etc., handled as required, no re-serving of portions once served to an individual 4; food containers stored above floor and protected from contamination 2; pets and other animals not allowed where food is prepared or stored, nor in serving area (unless caged or otherwise restricted) 4 ( )
- 4 FOOD SERVICE UTENSILS AND EQUIPMENT: Food service utensils and equipment in good repair and kept clean 4; eating and drinking utensils clean to sight and touch, cleaned after each use; approved facilities 4; clean utensils properly stored 2; substances containing poisonous material not used for cleaning or polishing eating or cooking utensils 6; disposable items properly stored and handled, used only once 2 ( )
- 5 FOOD SERVICE PERSONS: Clean clothes, hands, and work habits 4 ( )
- 6 DRINKING WATER FACILITIES: ICE HANDLING: Common drinking cups not used 4; ice, if provided, handled and dispensed in a sanitary manner 2 ( )
- 7 HOT AND COLD WATER: Adequate hot and cold water piped to points of use 4 ( )
- 8 TOILET, HANDWASHING: LAUNDRY AND BATHING FACILITIES: Toilet, lavatory and bathing facilities adequate 4; fixtures in good repair and kept clean 2; soap and towels provided 2 ( )
- 9 BEDS: LINEN: FURNITURE: All furniture, mattresses, linen, drapes, blinds and similar items in good repair and clean 2; bed linen changed as required 2; clean and soiled linens properly stored and handled 2 ( )
- 10 STORAGE: MISCELLANEOUS: Rooms or areas provided for storage of clothes, personal effects, luggage, supplies and equipment kept clean 2; medications, cleaning supplies, pesticides and other hazardous products properly stored as required 4 ( )
- 11 FLOORS: In good repair 1; kept clean 2 ( )
- 12 WALLS AND CEILINGS: In good repair 1; kept clean 2 ( )
- 13 LIGHTING AND VENTILATION: Windows and fixtures in good repair 1; kept clean 2 ( )
- 14 VERMIN CONTROL: PREMISES: Outside openings effectively screened or otherwise protected against entrance of flying insects, and flying insects absent 4; effective control of rodents and other vermin 4; approved pesticides properly used 4; premises neat, clean, drained and free of litter and vermin harborages and breeding areas 2 ( )
- 15 SOLID WASTES: Garbage in standard containers, properly covered and stored, approved disposal 4; containers, storage area kept clean 2; dry rubbish in suitable receptacles, approved storage and disposal 2 ( )

General Comments:  
 For water 1111. This cottage is approved for 6 residents, as per DSS requirements.

TOTAL DEMERIT SCORE 0

Inspection By: Roger Beeman

*[Signature]*  
 DATE: 05/13/2011

Report received by: \_\_\_\_\_

NC. Department of Environmental and Natural Resources  
Division of Environmental Health  
INSPECTION OF  
RESIDENTIAL CARE FACILITY  
(For facilities, as defined, with  
not more than 12 residents)

Demerit Score: 0  
Date of Insp/Chg: 05/12/2011  
Status Code: A

Health Department: BUNCOMBE  
Current Facility ID: 01011430020  
Old Facility ID:

Water Supply	<input checked="" type="checkbox"/> Community Transient Non-Community	Non-Transient Non-Community Non-Public Water Supply	Water sample taken? <input checked="" type="checkbox"/> Inspection Visit Re-Inspection	Yes <input checked="" type="checkbox"/> No Name Change Status Change Verification of Closure
Wastewater	<input checked="" type="checkbox"/> Community	On-Site System		

Name of Establishment: ELIADA HOME REUTER COTTAGE  
Location Address: 2 COMPTON DR

Permittee: ELIADA HOMES  
Number of Residents: 9  
Mailing Addr: P.O. BOX 16708

City: ASHEVILLE State: NC Zip: 28816 City: ASHEVILLE State: NC Zip: 28818

Approved (20 or less demerits, and no 6-point deductions)  
Provisional (More than 20, but 40 or less demerits, or a 6-point demerit)  
Family Foster Home (Only items 1 and 2 apply)  
Disapproved (More than 40 demerits or failure to improve provisional classification)

Demerits COMMENTS

- 1 WATER SUPPLY: Public supply; private supply approved 6 ( )
- 2 LIQUID WASTES: Sewage and other liquid wastes disposed of by approved method 6 ( )
- 3 FOOD SUPPLIES AND PROTECTION: Supplies: All food clean, wholesome, no spoilage 6; Protection: Adequate during storage, preparation and serving, potentially hazardous food 45? F or below, or 140? F or above 5; all refrigerators with thermometers 2; pork, ground beef products, poultry and stuffings, etc., thoroughly cooked; meat and poultry salad, potato salad, etc., handled as required, no re-serving of portions once served to an individual 4; food containers stored above floor and protected from contamination 2; pets and other animals not allowed where food is prepared or stored, nor in serving area (unless caged or otherwise restricted) 4 ( )
- 4 FOOD SERVICE UTENSILS AND EQUIPMENT: Food service utensils and equipment in good repair and kept clean 4; eating and drinking utensils clean to sight and touch, cleaned after each use; approved facilities 4; clean utensils properly stored 2; substances containing poisonous material not used for cleaning or polishing eating or cooking utensils 6; disposable items properly stored and handled, used only once 2 ( )
- 5 FOOD SERVICE PERSONS: Clean clothes, hands, and work habits 4 ( )
- 6 DRINKING WATER FACILITIES: ICE HANDLING: Common drinking cups not used 4; ice, if provided, handled and dispensed in a sanitary manner 2 ( )
- 7 HOT AND COLD WATER: Adequate hot and cold water piped to points of use 4 ( )
- 8 TOILET: HANDWASHING: LAUNDRY AND BATHING FACILITIES: Toilet, lavatory and bathing facilities adequate 4; fixtures in good repair and kept clean 2; soap and towels provided 2 ( )
- 9 BEDS: LINEN: FURNITURE: All furniture, mattresses, linen, drapes, blinds and similar items in good repair and clean 2; bed linen changed as required 2; clean and soiled linens properly stored and handled 2 ( )
- 10 STORAGE: MISCELLANEOUS: Rooms or areas provided for storage of clothes, personal effects, luggage, supplies and equipment kept clean 2; medications, cleaning supplies, pesticides and other hazardous products properly stored as required 4 ( )
- 11 FLOORS: In good repair 1; kept clean 2 ( )
- 12 WALLS AND CEILINGS: In good repair 1; kept clean 2 ( )
- 13 LIGHTING AND VENTILATION: Windows and fixtures in good repair 1; kept clean 2 ( )
- 14 VERMIN CONTROL: PREMISES: Outside openings effectively screened or otherwise protected against entrance of flying insects, and flying insects absent 4; effective control of rodents and other vermin 4; approved pesticides properly used 4; premises neat, clean, drained and free of litter and vermin harborages and breeding areas 2 ( )
- 15 SOLID WASTES: Garbage in standard containers, properly covered and stored, approved disposal 4; containers, storage area kept clean 2; dry rubbish in suitable receptacles, approved storage and disposal 2 ( )

General Comments:  
No water 110F. ( Correction of  
number of residents permitted from  
8 to 9 as per Kathy Pont at Elida  
Home )

TOTAL DEMERIT SCORE 0

Inspection By: Roger Beeman

EHS ID: 002

Report received by:

NC. Department of Environmental and Natural Resources  
Division of Environmental Health

**INSPECTION OF  
RESIDENTIAL CARE FACILITY**  
(For facilities, as defined, with  
not more than 12 residents)

**Demerit Score: 0**  
**Date of Insp/Chg: 05/13/2011**  
**Status Code: A**

**Health Department: BUNCOMBE**  
**Current Facility ID: 01011430018**  
**Old Facility ID:**

<b>Water Supply</b>	<input checked="" type="checkbox"/> Community <input type="checkbox"/> Transient Non-Community	<input type="checkbox"/> Non-Transient Non-Community <input type="checkbox"/> Non-Public Water Supply	<b>Water sample taken?</b> <input type="checkbox"/> Yes <input checked="" type="checkbox"/> No
<b>Wastewater</b>	<input checked="" type="checkbox"/> Community <input type="checkbox"/> On-Site System	<input type="checkbox"/> On-Site System	<input checked="" type="checkbox"/> Inspection <input type="checkbox"/> Visit <input type="checkbox"/> Re-Inspection
			<input type="checkbox"/> Name Change <input type="checkbox"/> Status Change <input type="checkbox"/> Verification of Closure

**Name of Establishment:** ELIADA HOME CUMMING COTTAGE  
**Location Address:** 2 COMPTON DR

**Permittee:** ELIADA HOME  
**Number of Residents:** 6  
**Mailing Addr:** P.O. BOX 16708

**City:** ASHEVILLE **State:** NC **Zip:** 28816

**City:** ASHEVILLE **State:** NC **Zip:** 28816

**Approved** (20 or less demerits, and no 6-point deductions)  
 **Provisional** (More than 20, but 40 or less demerits, or a 6-point demerit)

**Family Foster Home** (Only items 1 and 2 apply)  
 **Disapproved** (More than 40 demerits or failure to improve provisional classification)  
**Demerits** **COMMENTS**

- 1 **WATER SUPPLY:** Public supply; private supply approved 6 ( )
- 2 **LIQUID WASTES:** Sewage and other liquid wastes disposed of by approved method 6 ( )
- 3 **FOOD SUPPLIES AND PROTECTION:** Supplies: All food clean, wholesome, no spoilage 6; Protection: Adequate during storage, preparation and serving, potentially hazardous food 45? F or below, or 140? F or above 5; all refrigerators with thermometers 2; pork, ground beef products, poultry and stuffings, etc., thoroughly cooked; meat and poultry salad, potato salad, etc., handled as required, no re-serving of portions once served to an individual 4; food containers stored above floor and protected from contamination 2; pets and other animals not allowed where food is prepared or stored, nor in serving area (unless caged or otherwise restricted) 4 ( )
- 4 **FOOD SERVICE UTENSILS AND EQUIPMENT:** Food service utensils and equipment in good repair and kept clean 4; eating and drinking utensils clean to sight and touch, cleaned after each use; approved facilities 4; clean utensils properly stored 2; substances containing poisonous material not used for cleaning or polishing eating or cooking utensils 6; disposable items properly stored and handled, used only once 2 ( )
- 5 **FOOD SERVICE PERSONS:** Clean clothes, hands, and work habits 4 ( )
- 6 **DRINKING WATER FACILITIES: ICE HANDLING:** Common drinking cups not used 4; ice, if provided, handled and dispensed in a sanitary manner 2 ( )
- 7 **HOT AND COLD WATER:** Adequate hot and cold water piped to points of use 4 ( )
- 8 **TOILET: HANDWASHING: LAUNDRY AND BATHING FACILITIES:** Toilet, lavatory and bathing facilities adequate 4; fixtures in good repair and kept clean 2; soap and towels provided 2 ( )
- 9 **BEDS: LINEN: FURNITURE:** All furniture, mattresses, linen, drapes, blinds and similar items in good repair and clean 2; bed linen changed as required 2; clean and soiled linens properly stored and handled 2 ( )
- 10 **STORAGE: MISCELLANEOUS:** Rooms or areas provided for storage of clothes, personal effects, luggage, supplies and equipment kept clean 2; medications, cleaning supplies, pesticides and other hazardous products properly stored as required 4 ( )
- 11 **FLOORS:** In good repair 1; kept clean 2 ( )
- 12 **WALLS AND CEILINGS:** In good repair 1; kept clean 2 ( )
- 13 **LIGHTING AND VENTILATION:** Windows and fixtures in good repair 1; kept clean 2 ( )
- 14 **VERMIN CONTROL: PREMISES:** Outside openings effectively screened or otherwise protected against entrance of flying insects, and flying insects absent 4; effective control of rodents and other vermin 4; approved pesticides properly used 4; premises neat, clean, drained and free of litter and vermin harborage and breeding areas 2 ( )
- 15 **SOLID WASTES:** Garbage in standard containers, properly covered and stored, approved disposal 4; containers, storage area kept clean 2; dry rubbish in suitable receptacles, approved storage and disposal 2 ( )

**General Comments:**  
Hot water 110F. ( Correction of number of residents to 6 from 8 as stated in above permit information. As per Kathy Pont of Elida Home )

**TOTAL DEMERIT SCORE** 0

**Inspection By:** Roger Deeman  
DENR 2004 (Revised 11-01)  
Environmental Health Services Section (Revised 11-01)

*[Handwritten Signature]*  
INSPECTOR: 4972

**Report received by:**

NC. Department of Environmental and Natural Resources  
 Division of Environmental Health  
**INSPECTION OF**  
**RESIDENTIAL CARE FACILITY**  
 (For facilities, as defined, with  
 not more than 12 residents)

**Demerit Score: 0**  
**Date of Insp/Chg: 05/13/2011**  
**Status Code: A**

**Health Department: BUNCOMBE**  
**Current Facility ID: 01011430019**  
**Old Facility ID:**

<b>Water Supply</b>	<input checked="" type="checkbox"/> Community	<input type="checkbox"/> Non-Transient Non-Community	<b>Water sample taken?</b> <input type="checkbox"/> Yes <input checked="" type="checkbox"/> No
	<input type="checkbox"/> Transient Non-Community	<input type="checkbox"/> Non-Public Water Supply	<input checked="" type="checkbox"/> Inspection
			<input type="checkbox"/> Name Change
			<input type="checkbox"/> Visit
<b>Wastewater</b>	<input checked="" type="checkbox"/> Community	<input type="checkbox"/> On-Site System	<input type="checkbox"/> Re-Inspection
			<input type="checkbox"/> Verification of Closure

**Name of Establishment:** ELIADA HOME LION'S COTTAGE

**Permittee:** ELIADA HOME

**Location Address:** 2 COMPTON DR

**Number of Residents:** 9

**Mailing Addr:** P.O. BOX 16708

**City:** ASHEVILLE

**State:** NC

**Zip:** 28816

**City:** ASHEVILLE

**State:** NC

**Zip:** 28816

Approved (20 or less demerits, and no 6-point deductions)

Provisional (More than 20, but 40 or less demerits, or a 6-point demerit)

Family Foster Home (Only items 1 and 2 apply)

Disapproved (More than 40 demerits or failure to improve provisional classification)

Demerits

COMMENTS

- 1 **WATER SUPPLY:** Public supply; private supply approved 6 ( )
- 2 **LIQUID WASTES:** Sewage and other liquid wastes disposed of by approved method 6 ( )
- 3 **FOOD SUPPLIES AND PROTECTION:** Supplies: All food clean, wholesome, no spoilage 6; Protection: Adequate during storage, preparation and serving, potentially hazardous food 45? F or below, or 140? F or above 5; all refrigerators with thermometers 2; pork, ground beef products, poultry and stuffings, etc., thoroughly cooked; meat and poultry salad, potato salad, etc., handled as required, no re-serving of portions once served to an individual 4; food containers stored above floor and protected from contamination 2; pets and other animals not allowed where food is prepared or stored, nor in serving area (unless caged or otherwise restricted) 4 ( )
- 4 **FOOD SERVICE UTENSILS AND EQUIPMENT:** Food service utensils and equipment in good repair and kept clean 4; eating and drinking utensils clean to sight and touch, cleaned after each use; approved facilities 4; clean utensils properly stored 2; substances containing poisonous material not used for cleaning or polishing eating or cooking utensils 6; disposable items properly stored and handled, used only once 2 ( )
- 5 **FOOD SERVICE PERSONS:** Clean clothes, hands, and work habits 4 ( )
- 6 **DRINKING WATER FACILITIES: ICE HANDLING:** Common drinking cups not used 4; ice, if provided, handled and dispensed in a sanitary manner 2 ( )
- 7 **HOT AND COLD WATER:** Adequate hot and cold water piped to points of use 4 ( )
- 8 **TOILET: HANDWASHING: LAUNDRY AND BATHING FACILITIES:** Toilet, lavatory and bathing facilities adequate 4; fixtures in good repair and kept clean 2; soap and towels provided 2 ( )
- 9 **BEDS: LINEN: FURNITURE:** All furniture, mattresses, linen, drapes, blinds and similar items in good repair and clean 2; bed linen changed as required 2; clean and soiled linens properly stored and handled 2 ( )
- 10 **STORAGE: MISCELLANEOUS:** Rooms or areas provided for storage of clothes, personal effects, luggage, supplies and equipment kept clean 2; medications, cleaning supplies, pesticides and other hazardous products properly stored as required 4 ( )
- 11 **FLOORS:** In good repair 1; kept clean 2 ( )
- 12 **WALLS AND CEILINGS:** In good repair 1; kept clean 2 ( )
- 13 **LIGHTING AND VENTILATION:** Windows and fixtures in good repair 1; kept clean 2 ( )
- 14 **VERMIN CONTROL: PREMISES:** Outside openings effectively screened or otherwise protected against entrance of flying insects, and flying insects absent 4; effective control of rodents and other vermin 4; approved pesticides properly used 4; premises neat, clean, drained and free of litter and vermin harborage and breeding areas 2 ( )
- 15 **SOLID WASTES:** Garbage in standard containers, properly covered and stored, approved disposal 4; containers, storage area kept clean 2; dry rubbish in suitable receptacles, approved storage and disposal 2 ( )

**General Comments:**  
 Hot water 109F.

**TOTAL DEMERIT SCORE** 0

ELHS ID#: 6972

**Inspection By:** Roger Beeman

DENR 2094 (Revised 11/01)

Environmental Health Services Section (Review 11/04)

**Report received by:**

x *Andrea*

**INSPECTION OF  
RESIDENTIAL CARE FACILITY**  
(For facilities, as defined, with  
not more than 12 residents)

**Demerit Score: 0**  
**Date of Insp/Chg: 05/13/2011**  
**Status Code: A**

**Health Department: BUNCOMBE**  
**Current Facility ID: 01011430250**  
**Old Facility ID:**

<b>Water Supply</b>	<input checked="" type="checkbox"/> Community	<input type="checkbox"/> Non-Transient Non-Community	<b>Water sample taken?</b> <input type="checkbox"/> Yes <input checked="" type="checkbox"/> No
	<input type="checkbox"/> Transient Non-Community	<input type="checkbox"/> Non-Public Water Supply	
<b>Wastewater</b>	<input checked="" type="checkbox"/> Community	<input type="checkbox"/> On-Site System	<input type="checkbox"/> Name Change
			<input type="checkbox"/> Visit
			<input type="checkbox"/> Status Change
			<input type="checkbox"/> Re-Inspection
			<input type="checkbox"/> Verification of Closure

**Name of Establishment:** ELIADA HOME REYNOLD'S COTTAGE  
**Location Address:** 2 COMPTON DR

**Permittee:** ELIADA HOME  
**Number of Residents:** 9  
**Mailing Addr:** P.O. BOX 16708

**City:** ASHEVILLE **State:** NC **Zip:** 28806 **City:** ASHEVILLE **State:** NC **Zip:** 28816

Approved (20 or less demerits, and no 6-point deductions)  Family Foster Home (Only items 1 and 2 apply)  
 Provisional (More than 20, but 40 or less demerits, or a 6-point demerit)  Disapproved (More than 40 demerits or failure to improve provisional classification)

**Demerits** **COMMENTS**

- 1 **WATER SUPPLY:** Public supply; private supply approved 6 ( )
- 2 **LIQUID WASTES:** Sewage and other liquid wastes disposed of by approved method 6 ( )
- 3 **FOOD SUPPLIES AND PROTECTION:** Supplies: All food clean, wholesome, no spoilage 6; Protection: Adequate during storage, preparation and serving, potentially hazardous food 45? F or below, or 140? F or above 5; all refrigerators with thermometers 2; pork, ground beef products, poultry and stuffings, etc., thoroughly cooked; meat and poultry salad, potato salad, etc., handled as required, no re-serving of portions once served to an individual 4; food containers stored above floor and protected from contamination 2; pets and other animals not allowed where food is prepared or stored, nor in serving area (unless caged or otherwise restricted) 4 ( )
- 4 **FOOD SERVICE UTENSILS AND EQUIPMENT:** Food service utensils and equipment in good repair and kept clean 4; eating and drinking utensils clean to sight and touch, cleaned after each use; approved facilities 4; clean utensils properly stored 2; substances containing poisonous material not used for cleaning or polishing eating or cooking utensils 6; disposable items properly stored and handled, used only once 2 ( )
- 5 **FOOD SERVICE PERSONS:** Clean clothes, hands, and work habits 4 ( )
- 6 **DRINKING WATER FACILITIES: ICE HANDLING:** Common drinking cups not used 4; ice, if provided, handled and dispensed in a sanitary manner 2 ( )
- 7 **HOT AND COLD WATER:** Adequate hot and cold water piped to points of use 4 ( )
- 8 **TOILET: HANDWASHING: LAUNDRY AND BATHING FACILITIES:** Toilet, lavatory and bathing facilities adequate 4; fixtures in good repair and kept clean 2; soap and towels provided 2 ( )
- 9 **BEDS: LINEN: FURNITURE:** All furniture, mattresses, linen, drapes, blinds and similar items in good repair and clean 2; bed linen changed as required 2; clean and soiled linens properly stored and handled 2 ( )
- 10 **STORAGE: MISCELLANEOUS:** Rooms or areas provided for storage of clothes, personal effects, luggage, supplies and equipment kept clean 2; medications, cleaning supplies, pesticides and other hazardous products properly stored as required 4 ( )
- 11 **FLOORS:** In good repair 1; kept clean 2 ( )
- 12 **WALLS AND CEILINGS:** In good repair 1; kept clean 2 ( )
- 13 **LIGHTING AND VENTILATION:** Windows and fixtures in good repair 1; kept clean 2 ( )
- 14 **VERMIN CONTROL: PREMISES:** Outside openings effectively screened or otherwise protected against entrance of flying insects, and flying insects absent 4; effective control of rodents and other vermin 4; approved pesticides properly used 4; premises neat, clean, drained and free of litter and vermin harborages and breeding areas 2 ( )
- 15 **SOLID WASTES:** Garbage in standard containers, properly covered and stored, approved disposal 4; containers, storage area kept clean 2; dry rubbish in suitable receptacles, approved storage and disposal 2 ( )

**General Comments:**  
Hot water 110f.

**TOTAL DEMERIT SCORE** 0

**Report received by:**

**Inspection By:** Roger Beeman  
DENR 2094 (Revised 11/01)  
Environmental Health Services Section (Review 11/04)

*Roger Beeman*  
0972

*Andrea H...*

## **Eliada Academy**

### **Handicap Accessibility**

All six (6) buildings have available handicapped accessibility in identified area.

Describe the method of finding a facility if one is not readily available at this time including information about the spatial needs of the school to best suit your adopted educational program and instructional methodologies. Does the applicant have a facility contingency plan should their initial efforts not be successful?

---

NA

**HEALTH AND SAFETY REQUIREMENTS (G.S. 115C-238.29F(a))**

Describe how the school plans to adhere to the requirements of the health and safety laws and regulations of the federal and state governments. Address how the proposed charter school will meet the following requirements:

- *Safety*

---

Eliada Academy is committed to the health, safety and well being of all students and staff. All Academy staff will be trained in First Aid, CPR and BBP during their initial pre-service training. Staff will complete re-certification training in all 3 of those trainings as required. All Eliada staff are trained in the agency's disaster/emergency plan during monthly agency orientation for new employees. Eliada Academy will have a staff representative on the agency's safety committee and will complete monthly safety inspections in all buildings and monthly safety and disaster drills. The safety committee reports quarterly to the agency's risk management team. Eliada Academy staff will also ensure the safety proofing of all buildings utilized for school purposes and will follow agency procedures for potential weapons and unsafe substances, and monitoring the inventory of such items.

- *Immunization of Students*

---

NC students are required by law to have certain immunizations prior to attending schools. Eliada Academy will require proof of immunizations during the referral and admission process. Documentation will include the student's age at administration of each vaccine, the number of doses, and the date of administration. Parents of students who have not had the proper immunizations will be advised about where they may obtain those immunizations prior to their child's enrollment in Eliada Academy. Parents may submit written requests to be exempted from immunizations for medical or religious reasons in accordance with state requirements.

- *Fire and Safety Regulations*

---

Eliada Academy meets building codes for fire and safety regulations. All buildings have annual fire and sanitation inspections by local officials as required by current licensure. The agency maintenance department will correct any deficiencies identified during inspections and report back to the local officials. Eliada Academy Director will schedule and conduct monthly fire and disaster drills. Teachers receive training on the agency disaster plan in agency orientation during their first month of employment. New students are oriented to the fire drill procedures upon enrollment. Exit and fire evacuation plans are posted in required locations in each building.

- *Food Inspections*

---

Eliada Academy will comply with the regulations set by the Department of Health and Human Services for food purchases, preparation, serving, and disposing of food and food products. Eliada's centralized kitchen meets all sanitation, licensure and health requirements, and works diligently to



correct any food preparation and food service concerns identified during inspections.

- *Hazardous Chemicals*

---

Eliada Academy will inform and train all staff who work with hazardous substances about the agency's policies/procedures. Material Safety Data sheets (MSDS) will be on site and available for review of anyone coming in contact with chemicals. Poison Control contact information will be posted in all classrooms. Eliada's maintenance department will manage and ensure compliance with all OSHA standards in this area.

- *Bloodborne Pathogens*

---

Eliada Academy will operate under the agency's Prevention and Control of Contagious and Infectious Diseases policy and procedure. The policy states that the agency and Eliada Academy will comply with applicable health and occupational safety regulations governing contagious or infectious diseases and problems associated with immunodeficiency. Current medical advice, universal precautions, work practice controls, and employment practice controls will be utilized for the prevention and control of hepatitis, TB, HIV/AIDS, and other contagious or infectious diseases. Staff will be trained in and expected to follow procedures for BBP, communicable disease prevention, TB testing, universal precautions, personal protective equipment, legal rights of persons with communicable diseases, post-exposure reporting, and required staff training.

- *Diabetes care plans*

---

Eliada Academy will identify students with special medical needs such as diabetes, asthma, or others during the intake and enrollment process. The agency's nursing staff will review medical documentation provided at enrollment, and will train staff to appropriately assist and support students with diabetes or other special medical needs. Staff will follow a Care Plan developed for management of the special medical needs.

- *Providing students in grades 9-12 with information on how a parent may lawfully abandon a newborn*

---

Eliada Academy will provide this information to high school students and their guardians at enrollment.

- *Providing parents and guardians with information about:*

- *Meningococcal meningitis and influenza and their vaccines at the beginning of each year*
- 

Eliada Academy will provide information to parents/guardians upon enrollment and at the beginning of each school year about meningococcal meningitis and influenza. Handouts will include information about vaccines, causes, symptoms, how they are spread, and where parents can get vaccines for their children.

- *Cervical cancer, cervical dysplasia, human papillomavirus, and the vaccines available to prevent diseases*
- 

Eliada Academy will provide information to parents/guardians upon enrollment and at the beginning of each school year about these diseases and the vaccines available to prevent these

diseases. Handouts will include causes, symptoms, how these diseases are transmitted, vaccines that can prevent them, benefits and possible side effects of vaccines, and where parents can get more information and vaccines for their children.

## **VII.**

# LEA IMPACT STATEMENT

Pursuant to G.S. 115C-238.29B(d), the charter school applicant must submit a copy of the application to the LEA in which the school will locate within seven days of the submission of the application to the Office of Charter Schools. Applicants are encouraged to submit their application to the LEA first so that proof of submission can be included in the complete application packet. The LEA may then submit information or comment directly to the Office of Charter Schools for consideration by the State Board of Education.

Please attach to this application a return receipt, or other documentation, verifying the applicant's timely submission of a copy of this application to the LEA.

See Return receipt or other documentation Download

## VI APPENDICES (OPTIONAL)

You may include numbered and indexed appendices to provide additional information that you believe will assist the State Board of Education in the consideration of your application.

See Appendix Download

## IX. SIGNATURE PAGE

The foregoing application is submitted on behalf of Eliada Academy, INC.. The undersigned has read the application and hereby declares that the information contained in it is true and accounts to the best of his/her information and belief. The undersigned further represent that the applicant has read the Charter School Law and agrees to be governed by it, other applicable laws, and SBE regulations.

Print/Type Name: Mark C. Upright

Position: President/CEO

Signature: \_\_\_\_\_



4/12/12

Date:

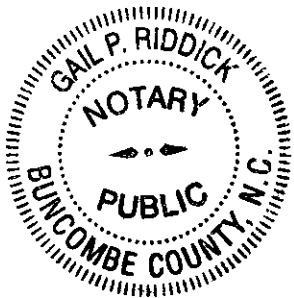

Sworn to and subscribed before me this

12 day of April, 2012.

Gail P. Riddick  
Notary Public Official Seal

My commission expires: 4/3, 2015.

U

U

U

## Table of Contents

Historic Perspective	1
Annual Report	4
Fall Newsletter 2011	52
Strategic Plan	68
Success Stories	72
Timeline Goals	78
Purposes of Proposed Charter School	79
A Brief Overview Program Evaluation Report FY 2011	81
2011-2012 FY Outcomes Measurement Framework	89
A Model of Learning Objectives	90
Bloom's Taxonomy	93
Curriculum Design	94
NETS Standards	99
Eliada Academy Day Treatment Class Schedule	101
Eliada Academy Residential Class Schedule	102
Pillars of School Culture	103
BASI Data 2010	104
BASI Report Form	105
Eliada Student Education Plan	108
Transition Plan 1	112
Transition Plan 2	120
Logic Model 2011-2012	142
School Calendar 2013-2014	143
Special Education Overview	144
Assessment Timeline	145
Title One	146
Title One Targeted Checklist	147
Behavior Model Summaries	148
Behavior Management	150
Grievance	153
Restrictive Interventions	155
Search and Seizure	163
Student Handbook	165
Timeline Start Up	190
Eliada Homes Audit	191
Admission Trends	196
Longitudinal Follow-Up	197
Eliada Academy Powerful Progress Stories	198
Academic Growth	201

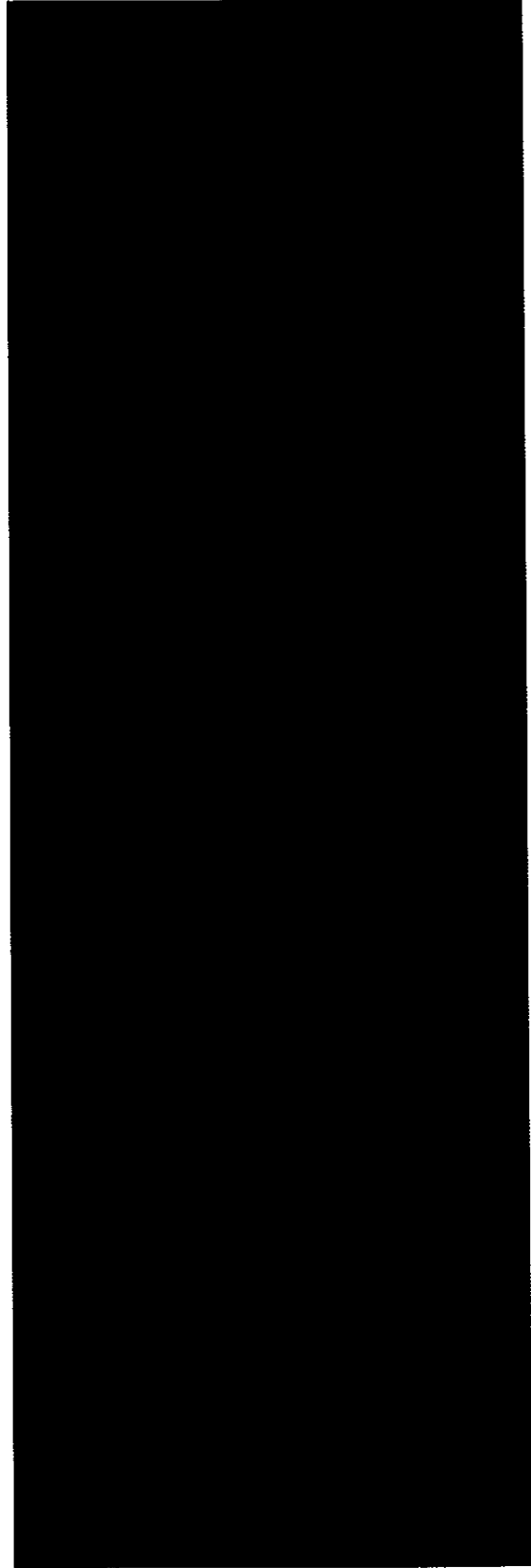



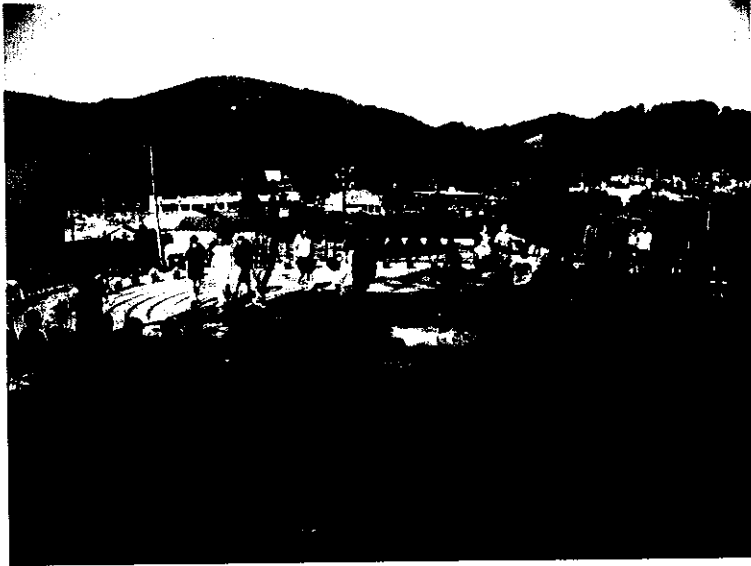

Labyrinth Opening  
Poetry Slam  
Talent Show



Most people can look back over the years and identify a time and place at which their lives changed significantly. Whether by accident or design, these are the moments when, because of a readiness within us and a collaboration with events occurring around us, we are forced to seriously reappraise ourselves and the conditions under which we live and to make certain choices that will affect the rest of our lives.

- Frederick F. Flack



FISCAL YEAR 08/09  
ANNUAL REPORT,  
STRATEGIC PLAN  
& 20 YEAR VISION

# CHARTING A PATH TO SUCCESS



# EL ADA

Faith, Hope & Love. Excellence. Teamwork. Integrity.



*Eliada, circa 1906. Dr. Compton is pictured to the far left.*

“Without a single dollar and without friends to pledge its support, the work had its beginning in prayers & tears which fanned faith into a flame of motion... but what has been done is so little compared with what is yet to be done.”

-Dr. Lucius B. Compton,  
Founder of Eliada (1909)

#### TABLE OF CONTENTS

3	Historic Timeline
5	Letter from the President & CEO
7	Programmatic Descriptions & Achievements
21	Financial Performance
27	Strategic Plan & 20 Year Vision
41	Thank You to Donors

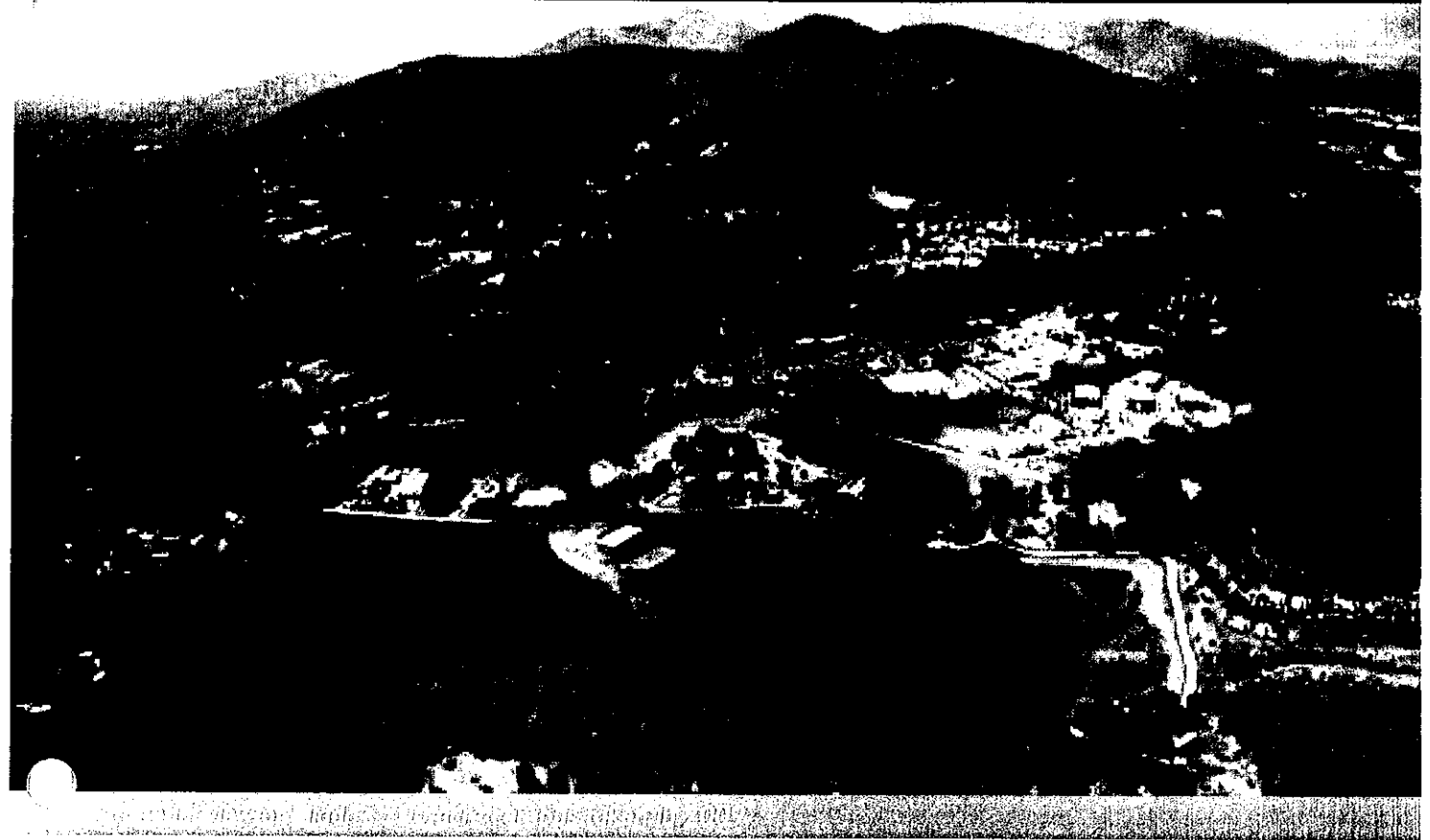

In 1903, Dr. Lucius B. Compton founded Eliada with a deep spiritual conviction to serve “the last, the least and the lost.” With little money, he began “Eliada Orphanage & Rescue Work” with a complete dependence on providential care. As the years went on Eliada grew to become a home and family to thousands of children with nowhere else to turn.

We continue Dr. Compton’s legacy of serving children and families in need through a diverse spectrum of programming designed to fulfill our mission: **Helping Children Succeed.** Today, we offer residential care, foster care, day treatment, case management, child development center services, and therapeutic recreation programming.

If you would like to learn more about Eliada, consider taking a tour of our historic West Asheville campus. Tours are offered each second and fourth Tuesday beginning at 10:30 am, and can be scheduled by phoning 828.254.5356 x 108 or emailing [dpope@eliada.org](mailto:dpope@eliada.org). More information can also be obtained by contacting us:

Eliada  
PO Box 16708  
Asheville, NC 28806  
828.254.5356 (phone)  
828.259.5384 (fax)  
[info@eliada.org](mailto:info@eliada.org)  
[www.eliada.org](http://www.eliada.org)

# A Legacy of Caring...

**1903**

Dr. Lucius B. Compton founds Faith Cottage as a home for unwed mothers.

**1910**

A farm is given to Eliada. Eventually, the farm incorporated a dairy barn that operated in conjunction with Biltmore Dairy.

**1960's**

Small cottages were built on Eliada's campus transitioning the children from dormitory living to cottage accommodations.



**1908**

As the number of children living in Faith Cottage grew, Dr. Compton saw the need for an orphanage, which he named 'Eliada', a biblical word meaning 'One for Whom God Cares.'

**1920's**

Dr. Compton and Eliada continued to grow, becoming a home for thousands of children. Throughout the time, Dr. Compton provided care on the farm and community support to community ministers.



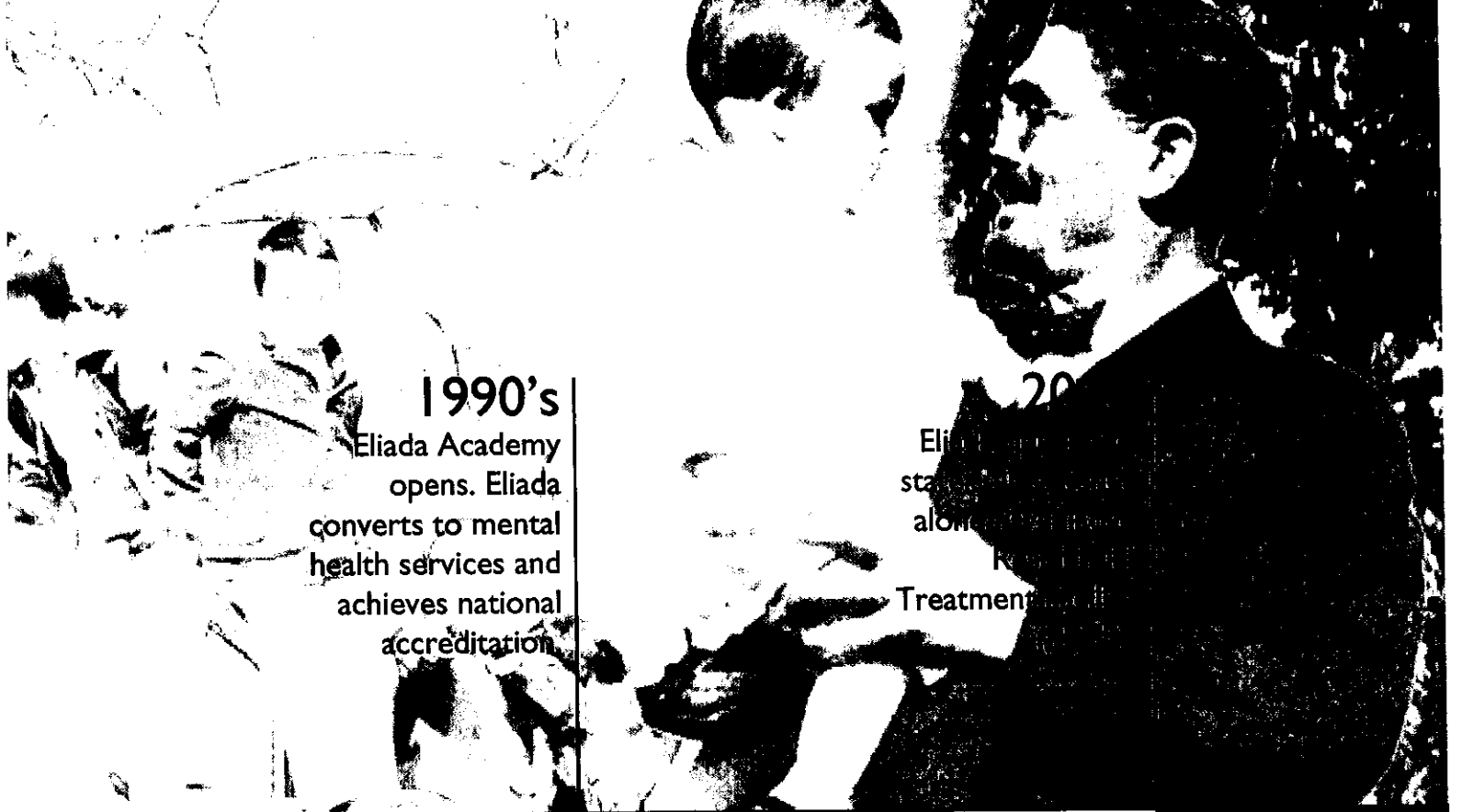

**1990's**  
 Eliada Academy  
 opens. Eliada  
 converts to mental  
 health services and  
 achieves national  
 accreditation.

**2000**  
 Eliada Academy  
 starts a residential  
 along with the  
 Residential  
 Treatment Center

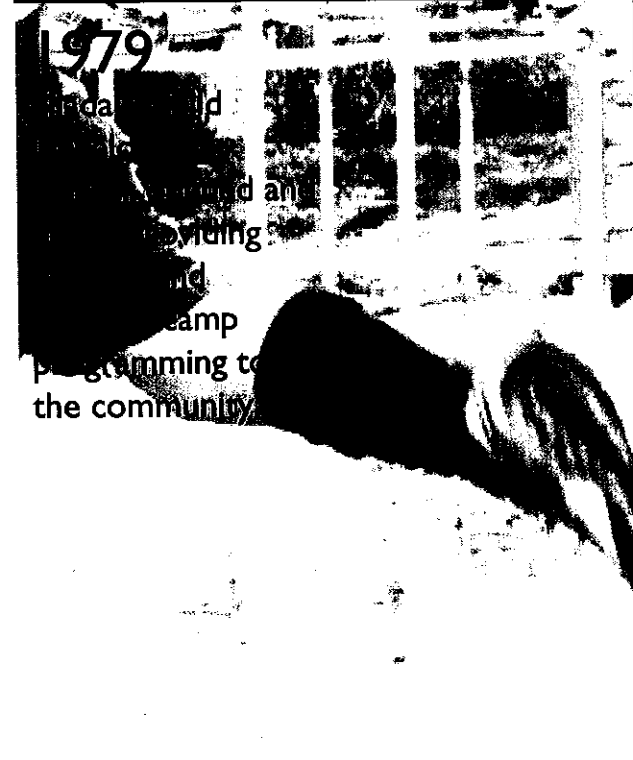
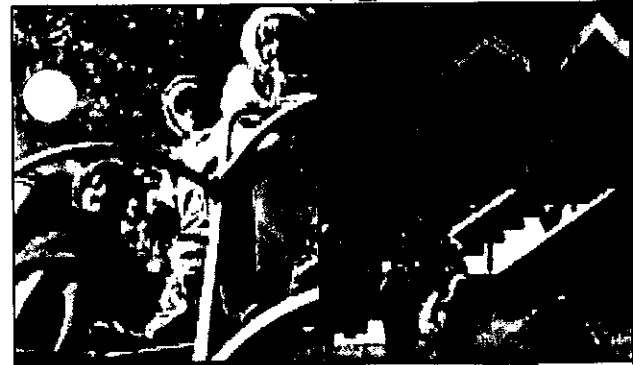

**1979**  
 Eliada Academy  
 is founded and  
 provides  
 camp  
 programming to  
 the community.

**2006**  
 Eliada Academy  
 Enhances  
 and a mental  
 program  
 The RIS  
 program  
 founded

**2010**  
 Responding to local  
 and state need,  
 Eliada transitions  
 to an all-PR JF  
 residential campus  
 for high-acuity  
 children and  
 adolescents.

## LETTER FROM THE PRESIDENT & CEO



“Make no little plans. They have no magic to stir men’s blood and probably themselves will not be realized. Make big plans. Aim high in hope and work, remembering that a noble, logical diagram once recorded will not die.”

-Daniel Burnham

Dear Friends of Eliada:

This may be the most comprehensive and important document we’ve ever issued.

This annual report lists not only our accomplishments of the past year, but also introduces our strategic plan and 20 year vision for Eliada. The ideas reflected in the 20 year vision are nearly seven years in the making, beginning with Eliada’s very first strategic plan in 2003. The new initiatives, programs, and focus areas described herein are exciting, and all of us at Eliada are proud and humbled by the potential they hold to positively impact the lives of children and families in need.

If Helping Children Succeed is a cause close to your heart, this is a document you will want to read carefully.

Many of the ideas you will read about are ambitious, such as our goal to open a degree-granting vocational school specifically designed for youth transitioning from the social service and mental health systems. Young people aging out of foster care or residential care will attend the vocational school to learn valuable skills and trades to help them rise above the statistics that characterize their demographic. Rather than enter adulthood with few marketable skills or resources, graduates of our vocational program will enter the working world with specialized ability, a technical degree, and the ability to be self-sufficient.

To realize this and many other goals within this report will take the dedicated commitment of our staff, students, donors, volunteers, board, and community. It will take countless hours of

research, planning, fundraising, and advocacy. Yet we cannot shy away because the goal is hard to reach; in the words of former Congressman Frank Clark, "If you can find a path with no obstacles, it probably doesn't lead anywhere."

We have accomplished lofty goals before. In our two previous strategic plans, we accomplished over 95% of the short and long-term objectives ahead of schedule. We have done the hard work of fleshing out our core values, looking honestly at our strengths as well as our weaknesses, and charting a focused and considered course to the future. Our foundation is solid, and, according to the plan outlined in the following pages, we are ready to enter a new era of service.

It has been said that a goal without a plan is just a wish, yet it takes more than just a plan to bring life to an idea. It also takes support. As a non-profit organization, Eliada was founded on the idea that not only do we serve the community, we also belong to the community. Each of you are a part of Eliada, and it will take each of you to make these goals a reality.

I will be upfront with you; if you are reading this report, you can expect a call from Eliada. We each have something unique to contribute to the future of this organization. Some may have financial resources, others may bring technical expertise, contacts, or volunteer time. We all have something important to give.

Thank you for taking the time to read this report. Share it with your friends, family, colleagues, and church members. If you have questions about any of these ideas or want to learn more, contact us. We operate with complete transparency and welcome the opportunity to share more about what we do.

Very Sincerely,

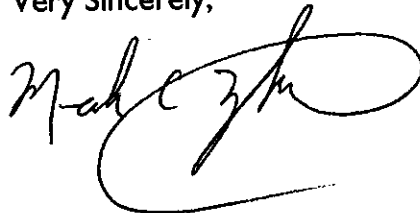
A handwritten signature in black ink, appearing to read "Mark C. Upright". The signature is fluid and cursive, with a large loop at the end.

Mark C. Upright, J.D., M.B.A.  
President & CEO  
Attorney at Law

**WHAT IS ELIADA?**



## **OUR MISSION**

Helping Children Succeed

## **OUR VISION**

To provide the optimal learning environment to empower children and their families to succeed

## **OUR CORE VALUES**

Faith, Hope, & Love, Excellence, Teamwork, Integrity

## **OUR CORE PURPOSE**

Eliada provides an environment in which children and their families can find their own unique gifts and strengths to reach their fullest potential



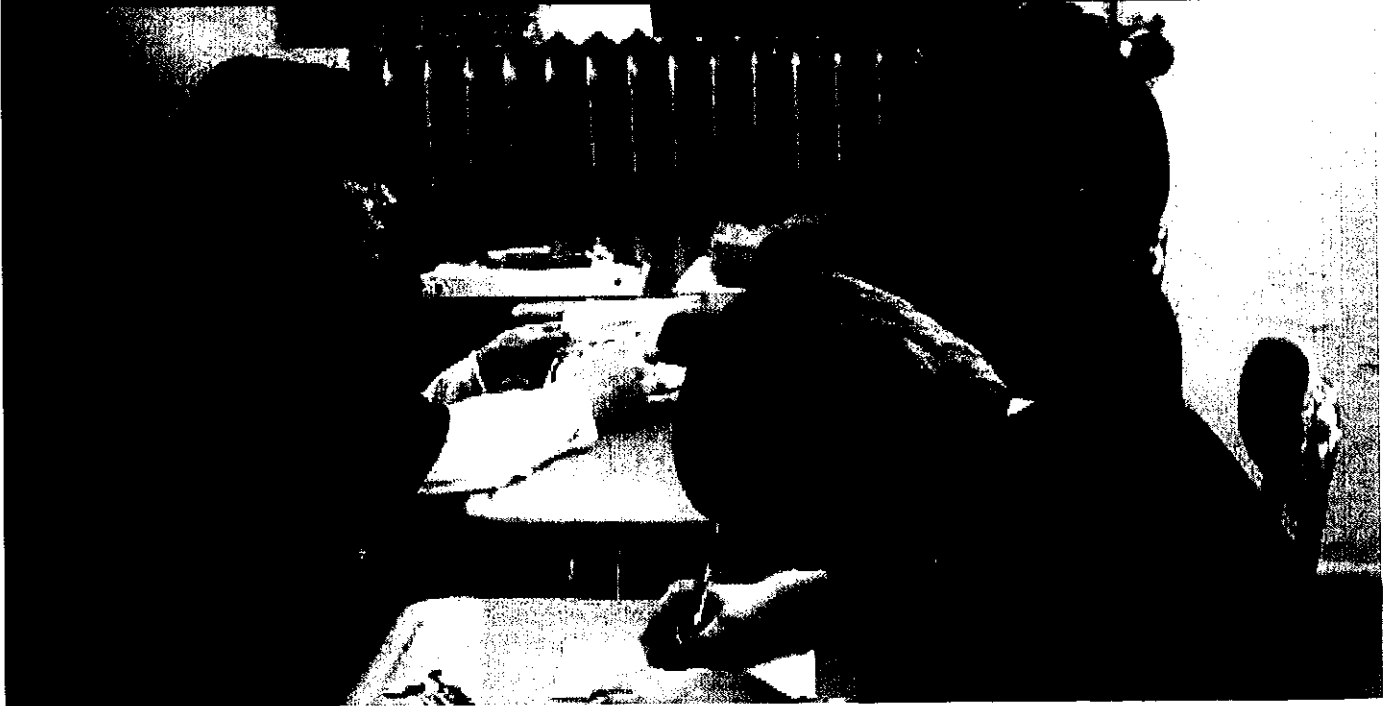

## TREATMENT PROGRAMS

Psychiatric Residential Treatment  
Facility (PRTF) services for  
children and adolescents

Foster care

Therapeutic foster care

Day treatment at Eliada Academy

Clinical services

Community Support &  
Case management

Program Evaluation

Eliada is committed to providing the highest quality of care for each child and family it serves. The Eliada Model is a comprehensive, solution-focused treatment approach that integrates best practices with an individualized treatment process. Our model blends behavioral, educational and clinical components to systematically implement the most appropriate service delivery.

The Eliada Model focuses on the development of vital social, academic and community living skills. Through clinical and program consultation, person centered plans are developed with the child and family to meet the needs of each student. Ongoing assessment of each child's plan is critical to maximize the child's strengths and abilities to reach individualized treatment goals.

Each child and family is treated with respect, dignity and cultural sensitivity. Confidentiality is safeguarded and students' care and treatment are characterized by competence and compassion. Health, safety, physical and emotional well-being of each student and family are paramount. Success is supported by involving families and communities. By working closely with individuals, families and agencies that are integral to the student, we are better able to provide treatment services that enable short and long-term success.

Every family has the capacity for growth and change, and every child needs a permanent, caring family. Eliada strives to reunify children and families, or when this is not possible, to secure a safe, loving and permanent alternative family.

## Devon Reaches for the Stars

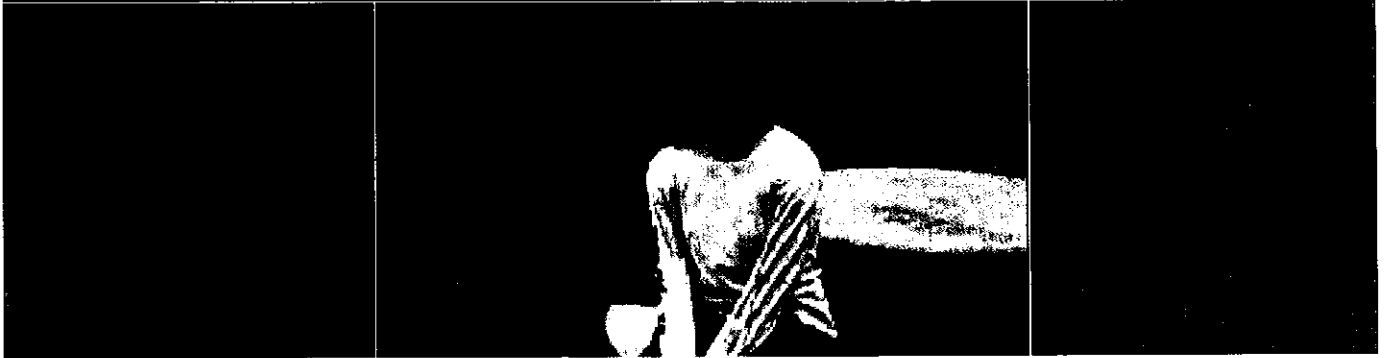

Before I stepped foot on Eliada's campus I was a child that had no respect for others. I was involved in drugs, alcohol, and running away and saw no wrong in it. I was thirteen and had always struggled with anger, depression, and never being the popular kid in school. I had been to seven prior facilities and none of them seemed to provide the help that I needed.

I remember sitting around a table with my counselors on my first day at Eliada. I thought, "I'm going to stay here, not talk to anybody, not make any friends, and get out. How hard could it be?" Within the next few months I struggled, not understanding that I had a whole world of opportunities at my fingertips. Living apart from my old life, I was isolated from the mistakes I'd made and all that was familiar to me.

Isolation from the real world is what really helped me. It wasn't total separation but it was enough for me to focus on my life. The sports and activities helped me get a break from dealing with my emotional troubles. I was involved in basketball, softball, track, and the NYPUM minibike program. We swam during the summer, went to the campus church on Sundays, and occasionally went on outings. I received two Silver Honor Roll certificates at Eliada Academy, the Martin Luther King Jr. award, NYPUM student of the month, art contest participant award, defensive player of the year award in basketball, best female comedian award, and two student of the month awards in English class. All of these activities gave me hope that I could change.

It took me seven months to realize what I had at stake. One night it finally hit me that Eliada was a second chance for me. I had two choices, I could stay in my same rebellious mindset and not change at all or I could give myself a chance and change for the better. That night I

looked up at the full moon and looked back at Cummings Cottage. I thought, "This Eliada experience is like walking uphill in sand. Its extremely difficult and tiring, emotionally and physically, but when you get to the top and look down you'll see the hill that couldn't hold you back. It'll be the biggest feeling of accomplishment that you have ever felt. Take it one step at a time and you will make it."

I used to take three medications daily to control my emotions. Now, I'm completely off all of them. I have been in a foster home since August 2006. I have a wonderful relationship with my foster family and adore where I'm living. I will graduate high school in 2010 and plan on going to a four-year college in 2011. I want to move to Asheville and be an interior designer. I have been taking violin lessons for two years and I love it. I'm comfortable with school and my grades are better than they've ever been.

I've been drug and alcohol free for a good while now and I couldn't have done it without support from Eliada. I'm ready to accept everything that life dishes out. I'm confident that I can make it through life successfully and never look back at what happened before.

When I look back at my past I think that going to Eliada is what truly helped me change my life around. I'm proud of myself and I have no doubt in my mind that I can do anything as long as I set my mind to it. If it wasn't for Eliada I don't know where I would be today. I hope that I can reach out to youth in need through my success story and give them a sense of hope. Everyone can change but sometimes they need a shoulder to lean on or a solid foundation to depend on. Eliada was there to help me, to stick with me through rough times or good times, to give me something to temporarily depend on, and to help me be the person I was born to be.

## Treatment Programs: Demographics

Total Served in FY 08/09: 307

Program	Age & Gender	Socio-economic Status	Ethnicity & Region of Origin	Representative Presenting Problems & Diagnoses	Case History & Representative Family Characteristics
Residential	8-18  75% Female 25% Male	80% Poverty/ Low Income  20% Middle Income	79% Caucasian 7% African American 7% Native American 7% Biracial 65% WNC	Suicidal ideation; post-traumatic stress; major depression; physical & sexual abuse	3-22 prior placements; family structure characterized by frequent separation, abandonment, mental health problems, domestic violence, financial instability, & suicide.
Foster Care & Therapeutic Foster Care	1-18  47% Female 53% Male	91% Poverty/ Low Income  9% Middle Income	89% Caucasian 6% Biracial 5% African American  94% WNC	Suicidal ideation; running away; conduct disorders; post-traumatic stress; anxiety disorders; physical & sexual abuse; neglect	70% have prior placements; family structure characterized by frequent separation, abandonment, mental health problems, substance abuse, financial instability, domestic violence, unsanitary living environments, lack of supervision, & exposure to pornography.
Day Treatment	8-18  49% Female 51% Male	90% Poverty/ Low Income  10% Lower Middle Income	80% Caucasian 7% African American 7% Hispanic 6% Biracial  73% Buncombe County	Aggression; attention problems; grief; abuse/neglect; mood disorders; attachment disorders; depressive disorders	1-5 prior placements; 40% performing one or more grades below grade level; family structure characterized by poverty, incarceration, dysfunction, substance abuse, & domestic violence.
Community Support & Case Management	5-19  63% Female 37% Male	90% Poverty/ Low Income  10% Middle Income	89% Caucasian 11% African American  100% WNC	Self-injurious behaviors; physical & sexual abuse; neglect; aggression; depression; post-traumatic stress, conduct & oppositional disorders	0-10 prior placements; family structure characterized by mental illness, unresolved grief, substance abuse, incarceration, lack of structure, unsanitary living environments, and lack of accountability.

# TREATMENT HIGHLIGHTS

## Psychiatric Residential Treatment Facility (PRTF) Program

Opened Earle Cottage, an unlocked 5-bed coed unit for young children in December, and reached full capacity in February. The first student graduated in April.

Responding to community need, we again expanded our PRTF program in late 2009. Cummings and Reuter cottages opened as PRTF units in September & November, thereby bringing our total capacity to 39 students.

Provided a crisis bed in Lions PRTF for the Western Highlands Network eight-county area. Crisis bed placements assisted children and families with stabilization of emergent situations, providing time to work on family issues and preventing costly psychiatric hospitalizations. All students were returned to their family, foster family, or group home after a 5-7 day crisis stay.

Made history with the first-ever PRTF theater performance on campus. Reynolds girls prepared and starred in their own unique version of Snow White & The Seven Dwarfs. Lions and Reynolds students worked for several weeks on an adaptation of Romeo & Juliet, while Earle children presented a talent show and student art exhibit.

Implemented on-site medical care for dentistry and x-rays.

Implemented a new residential staffing schedule which improved staffing patterns and job performance while lowering costs.

## Foster Care & Therapeutic Foster Care

Three children were adopted by their foster parents, and 3 children were placed in guardianship with their grandmother/foster mother.

Employed an experienced foster care recruiter and trainer who trained and licensed eight new foster homes.

Joined the NC Chapter of the Foster Family Treatment Association.

Converted to a field-based model with staff working out of their homes and agency vehicles, equipping staff with agency laptops, internet connections, copier/fax machines, and cell phones.

**Day Treatment**

Employed a new Education Director with vocational and technical education certification, administrative certification, experience as a middle school principal, and curriculum/instruction experience.

Employed a Title I Teacher to provide educational assessments & individualized instruction for students reading 2 or more levels below grade level.

Held the 3rd Annual Eliada Academy Winter Formal. Students and staff gathered at Eliada's recreation center for prom photos, dinner, and dancing.

**Clinical Services**

Restructured clinical services, adding a part-time psychologist to handle court commitments and a fourth therapist to meet the increased need for therapy and clinical supervision. Promoted an experienced therapist to the position of Clinical Director.

Two clinicians presented a workshop on Dialectical Behavior Therapy (DBT) with horses and adolescents at the national Equine Assisted Growth and Learning Association (EAGALA) conference in March.

**Community Support & Case Management**

Converted to a field-based model with staff working out of their homes and agency vehicles.

Achieved significant milestones with several clients, i.e. graduation from high school, completion of a nursing tech program, honor roll in public school, and obtaining a first job.

**Program Evaluation**

Piloted a longitudinal survey covering all areas of child well being (employment, living environment, education, physical and mental health, spiritual health, etc.). Implemented the full survey on July 1, 2009 in all program areas.

Successfully completed the Duke Endowment grant including transition to our current Program Evaluation Coordinator assuming management of the evaluation processes on July 1, 2009.

Revised logic models and outcomes measured based on experience in FY08. Standardized data collections processes with clear follow up and accountability.



## EDUCATION PROGRAMS

Child Development

Preschool

More at Four

Afterschool

Summer Camp

Eliada's Child Development Center serves over 400 infants, preschoolers, and school age children each year. Combining an enriching environment, highly educated staff members, and a dynamic approach to learning, Eliada's education programs aim to instill a positive self-concept from a very early age. The educational model, called *Foundations*, is based on the core ideas that:

- Each child is unique;
- Development occurs in predictable patterns;
- Young children are active learners;
- Many factors influence a child's development;
- Children with disabilities learn best in inclusive settings.

Child Development programming focuses on emotional and social development, health and physical development, language development and communication, and cognitive development. Our programs have attained 5-star licensing and are accredited by the National Association for the Education of Young Children (NAEYC).

# EDUCATION HIGHLIGHTS

## Child Development

Successfully maintained 5 star licensing (all programs), as well as NAEYC accreditation.

## Preschool

Teacher Karen Jeter was honored at the annual family choice awards for her work with special needs children. This is the second year in a row she has achieved this honor.

Engaged in a new nutrition initiative to set high food standards and incorporate farm-to-table concepts within the preschool curriculum.

Director invited to serve on the “Ready School” committee for Buncombe County schools.

Through membership with Buncombe County Local Interagency Community Council, continued to advocate for Early Intervention Services in the community.

## More at Four

Successfully graduated 86 children through the More at Four program.

Teachers Tara Robbins and Jennifer Donati presented 2 workshops at the Early Childhood Western Regional Conference.

## Afterschool

More at Four audits completed with full compliance.

Expanded the afterschool program to serve an average of 95 children each school year.

Created an outdoor classroom for homework and arts & crafts activities.

Intensified partnerships with schools and families to become more involved with high-risk children and a bigger part of their individual learning plans.

Worked with a school age specialist toward quality enhancement.

Creation of “The Bully Project”; produced by the children, for the children to educate on bullying and the consequences of bully behavior.

## Summer Camp

Increased summer camp capacity to serve 154 children and adolescents.

## { SUCCESS STORY }

### More at Four in Action

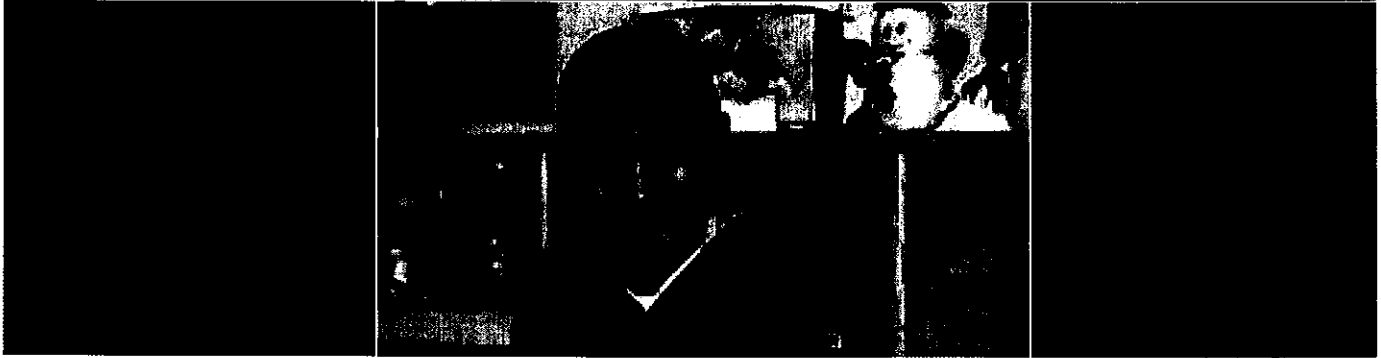

Joshua began attending Eliada's "More at Four" program in late August of 2009. "More at Four" is a free kindergarten readiness initiative designed to ensure that all children are able to enter school with basic skills and an equal chance for success. The program is especially helpful for children with developmental delays and can be an important opportunity for early intervention.

Joshua was a perfect candidate for the program, having been recently diagnosed with Autism. His mother had become concerned that Joshua didn't speak very often, instead expressing himself through temper tantrums and angry outbursts. She hoped that his experience at Eliada would help him work through these issues before he went to public school.

Fear of new environments can be a hallmark of autism, and Joshua initially struggled at Eliada. He had difficulty with transitions and interacting with other children his age. His tantrums continued and at times he would even hit his classmates to get their attention.

Joshua's teachers realized that in order for him to feel comfortable, Joshua needed a special routine and consistent structure to follow every day. They also realized the importance of modeling appropriate ways to express feelings and needs. The other classmates helped Joshua by guiding him to play nicely, often saying "Use your words, Joshua!"

Joshua now feels secure and happy in the classroom, and has made friends with many of the other children. He is able to interact with his peers and express basic needs using words in English and Spanish. With guidance and lots of hugs from his teachers, Joshua isn't hurting his friends and loves playing with them. He enjoys sitting down for story time and repeats the words aloud. His tantrums have ceased and he can often be seen with a big smile on his face! His mother reports that Joshua wakes up every morning at 5:30 am and tells her, "Mama, escuela!" ("Mom, school!").

The most important thing Joshua learned during his time in the More at Four program is the self-assurance to succeed in kindergarten. Now, he can enter school with basic knowledge and, more importantly, the communication and social skills that will enrich his relationships with teachers and peers.

Last year, 86 young students graduated from the More at Four program at Eliada. They took part in a graduation ceremony complete with caps, gowns, and diplomas, walking the stage in the presence of their teachers, families, and friends. We can only hope that for these students, this ceremony was only the first in a series of celebrations of the scholastic accomplishments they will achieve over their academic careers.



## Education Programs: Demographics

Total Served in FY 08/09: 411

Program	Age & Gender	Socio-economic Status	Ethnicity & Region of Origin	Presenting Reasons for Enrollment	Special Needs
Child Development (Preschool)	Infant: 17.75%; 12-23 months: 17.75%; 2 years: 25.64%; 3 years: 28.21%; 4 years: 10.26% 61.54% Female 38.46% Male	Poverty/Low Income: 48.69% Middle Income: 20.51% High Income: 20.51% (7.6% Unreported)	64% Caucasian 21% Multiracial 10% Hispanic 5% African American 93% Buncombe County	92% Working parents 8% Parents attending school	97% None 3% Asthma
More at Four	4 years: 80% 5 years: 20% 52% Female 48% Male	Poverty/Low Income: 78% Middle Income: 2% High Income: 6% (14% Unreported)	70% Caucasian 12% Multiracial 8% Hispanic 4% African American 4% Native American 100% Buncombe County	44% Kindergarten readiness 34% Working parents 10% Parents attending school 10% Development needs/physician referral	68% None 6% Developmental delay 6% Speech/language delays 4% Asthma 2% ADHD/ADD 4% Other
Afterschool & Summer Camp	5-10 years: 88% 10-15 years: 12% 56% Female 44% Male	Poverty/Low Income: 60% Middle Income: 9% High Income: 14% (17% Unreported)	77% Caucasian 10% Hispanic 7% African American 6% Multiracial	86% Working parents 8% Parents attending school 6% Development needs/physician referral	57% None 16% ADHD/ADD 11% Asthma 9% Speech/language delays 3% Developmental delays 1% Autism 1% Learning disabilities 3% Other

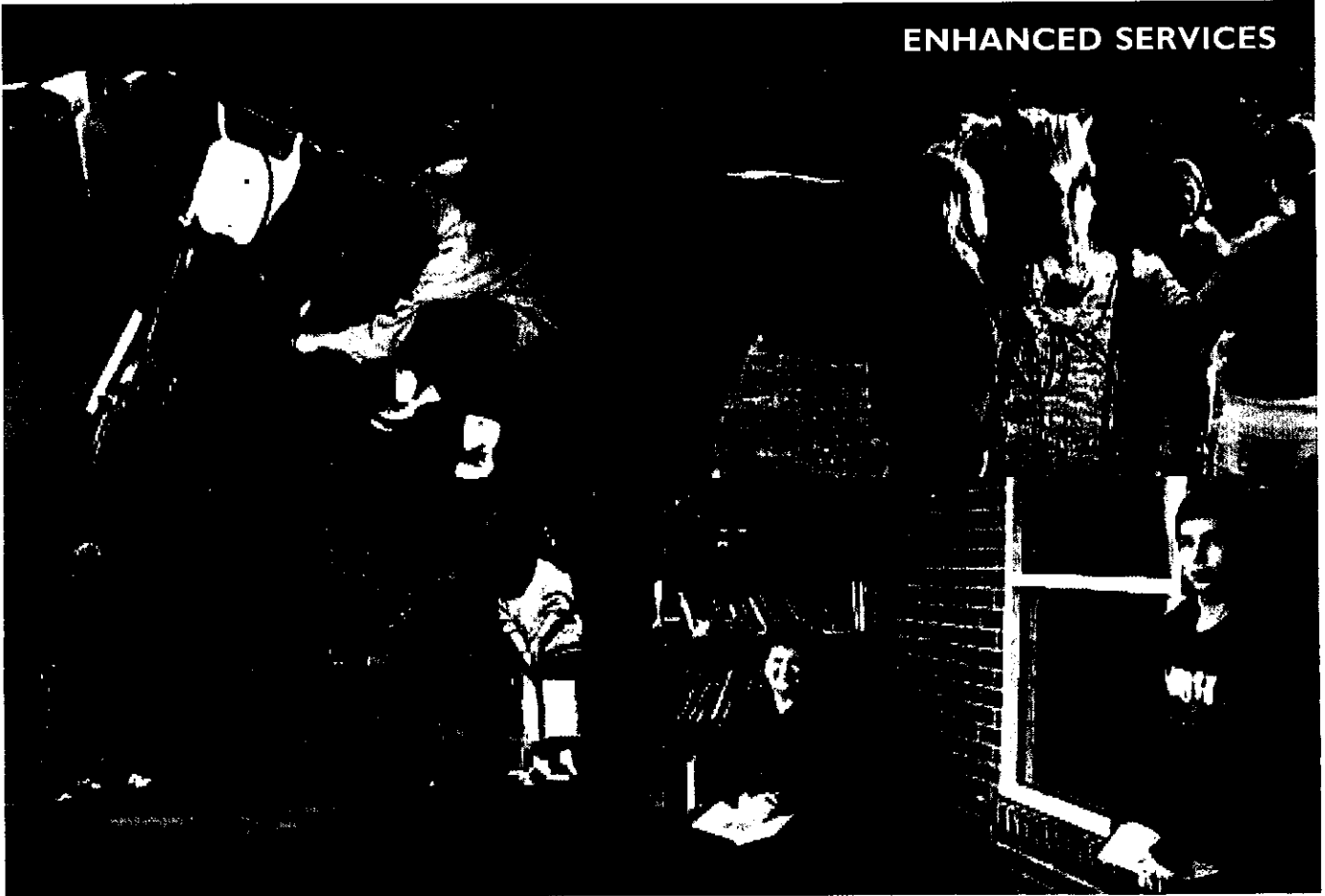

## ENHANCED SERVICES PROGRAMS

National Youth Project Using  
Minibikes (NYPUM)

Therapeutic Animal Stewardship  
Cooperative (TASC)

Intramural Athletics

Spiritual Development

Independent Living

Enhanced Services provide a unique opportunity for our students to participate in engaging, fun and challenging activities that they may otherwise not have the opportunity to experience. Each of the programs is designed to build confidence, instill a healthy lifestyle and teach important character development traits. Whether it is learning to ride a dirt bike, care for a horse or responsibly complete the duties of an after-school job, the Enhanced Services programs bring enrichment, excitement and unique opportunities for growth to each of its participants.

The Enhanced Services department strives to make the students' experience challenging, fun and rewarding. By exposing students to unique opportunities in a supportive environment, we hope students learn the confidence to try new things and experience success in healthy and productive activities. In this department relationship are built, self-esteem is heightened, success is experienced and A LOT of fun is had by students and family members of all ages!

## ENHANCED SERVICES HIGHLIGHTS

### National Youth Project Using Minibikes (NYPUM)

Two residential leadership staff became certified NYPUM instructors.

Implemented students setting three personal development goals to earn riding time; students who met goals rode on Slippey Mountain and traveled to other communities to ride on special courses.

Eliada sent four high-achieving NYPUM students to the national NYPUM rodeo in Massachusetts, and is in the early stages of planning to host the 2010 Southeast Regional NYPUM rodeo on Eliada's campus.

Established a Junior Leaders program to reward hard work in the program and keep students involved after they graduate from Eliada.

### Therapeutic Animal Stewardship Cooperative (TASC)

Developed standard Horsemanship / Character Development Curriculum.

Added a miniature horse, five goats, and a llama to the TASC family.

Strengthened Eliada's relationship with Paws With A Purpose, a local non-profit. Hosted Paws With A Purpose certification day and developed an animal-assisted therapy curriculum specialized for our students.

### Athletics

Transitioned to intramural athletics teams to better serve high-acuity students.

Developed a standard Junior Golf/Character Development curriculum.

Partnered with Aston Park to offer tennis clinics to treatment students.

Built a relationship with UNCA student athletes who are volunteer coaches for Eliada students.

### Spiritual Development

Developed and implemented a spiritual development philosophy and guidelines. Hosted daily evening and morning prayers in the cottages, two church services on Sunday, a Sunday school class, a weekly girls youth group, Bible study for secured cottages, and another weekly Bible study for any student who wishes to participate.

### Independent Living

Offered summer jobs for students working in maintenance, child development, and community-based jobs.

## PROFESSIONAL LEADERSHIP DEVELOPMENT



### PROGRAMS

Residential Interns Seeking  
Excellence (RISE)

Clinical Internship Program

Child Development Internship  
Program

Eliada Institute

At Eliada, we are training the next generation of Human Services professionals and developing leaders within our own organizational structure. We believe in the power of on-the-job education, and in the idea of developing the skills and talents of our employees while tackling management-level problems.

We founded Eliada Institute in 2006. Eliada Institute is comprised of middle managers who meet monthly to work on a project of their choosing. Typically, these projects are broad-based efforts to improve the lives of our students and staff. While they work, they learn managerial skills and gain the ability to think holistically about intradepartmental issues outside of their normal focus area.

Many of our programs offer internship opportunities in partnership with local colleges and universities. In addition, we operate our own post-graduate residential internship program for new college graduates.

# LEADERSHIP HIGHLIGHTS

## Residential Interns Seeking Excellence (RISE)

In the past fiscal year, recruited 26 RISE interns from local colleges such as UNCA, Mars Hill, Warren Wilson, and Appalachian State, as well as from other areas including the United Kingdom and South Africa.

Four graduating RISE interns stayed on for a second year to serve as lead RISE staff.

RISE staff members provided invaluable service and flexibility during the snow storms of 2009/2010, ensuring that our residential cottages stayed fully staffed despite crippling blizzards and ice storms that prevented off-site staff from traveling to work.

## Clinical Internship Program

Hosted 2 clinical interns who went on to receive Master's Degrees in Community Counseling.

One intern presented "Integrating Play Therapy with Art and Music for Grieving Children and Adolescents" at the North Carolina Play Therapy Conference. Another intern provided specialized training on "Communication Techniques to Help With Rapport" to our staff in the cottages.

Due to the success of our previous interns and the valuable experience they gained at our site, our program has grown and we currently have 3 interns. We also developed a relationship with Appalachian State University to provide an internship site for their students in their Clinical Mental Health Counseling program.

## Child Development Internship Program

Currently hosting two Master's Level interns in the Child Development program.

## Eliada Institute

Developed a purchasing policy to improve the nutritional value of foods served in the cafeteria and cottages. Increased the agency's emphasis on fresh fruits and vegetables and set concrete standards for food quality.

Began the process of researching and recommending best practices in employee evaluation; preparing to rework the internal employee evaluation form based on this research.



# FINANCIAL PERFORMANCE

**Eliada Homes, Inc.**  
**Statement of Activities**  
July 1, 2008 - June 30, 2009

REVENUE		2009	2008
	Medicaid	\$6,406,851	\$5,848,179
	State & County	\$1,764,112	\$1,529,099
	Private Pay	\$449,617	\$426,216
	Grants & Gifts	\$369,465	\$437,139
	Eliada Foundation	\$273,666	\$959,301
	Miscellaneous	\$10,818	\$11,279
	<b>Total Revenue</b>	<b>\$9,274,529</b>	<b>\$9,211,213</b>

EXPENSES		2009	2008
	Personnel	\$6,679,953	\$6,658,498
	Program	\$1,202,995	\$1,208,728
	Occupancy & Communications	\$875,204	\$925,973
	Professional Fees	\$298,525	\$292,789
	Training & Travel	\$63,828	\$85,964
	Depreciation	\$88,100	\$84,145
	<b>TOTAL EXPENSES</b>	<b>\$9,208,605</b>	<b>\$9,256,097</b>
	<b>PROFIT/(LOSS)</b>	<b>\$65,924</b>	<b>(\$44,884)</b>
	<b>NET ASSETS</b>	<b>\$868,736</b>	<b>\$802,812</b>

These financial statements have been prepared on the accrual basis of accounting and conform to accounting principals generally accepted in the United States of America as applicable to not-for-profit organizations.

**Eliada Homes, Inc.**  
**Statement of Financial Position**  
June 30, 2009

<b>ASSETS</b>		2009	2008
	Cash	\$225,235	\$171,089
	Accounts Receivable	\$763,173	\$758,775
	Pledge Receivable	\$0	\$20,000
	Rec. from Eliada FDN	\$648	\$19,525
	Inventory	\$7,945	\$5,926
	Prepaid Expenses	\$56,744	\$78,968
	Property & Equipment	\$257,432	\$218,706
	Perpetual Trust	\$185,700	\$221,800
<b>TOTAL ASSETS</b>		<b>\$1,496,877</b>	<b>\$1,494,789</b>

<b>LIABILITIES</b>		2009	2008
	Accounts Payable	\$114,420	\$128,921
	Payroll Liabilities	\$355,450	\$440,827
	Other Liabilities	\$10,353	\$27,142
	Lease Payable	\$40,345	\$0
	Long-term Debt	\$107,573	\$89,479
	Payable to Eliada FDN	\$0	\$5,608
<b>TOTAL LIABILITIES</b>		<b>\$628,141</b>	<b>\$691,977</b>
<b>FUND BALANCE</b>			
	Unrestricted	\$671,325	\$492,087
	Temporarily Restricted	\$11,711	\$88,925
	Permanently Restricted	\$185,700	\$221,800
<b>TOTAL NET ASSETS</b>		<b>\$868,736</b>	<b>\$802,812</b>
<b>TOTAL LIABILITIES &amp; FUND BALANCE</b>		<b>\$1,496,877</b>	<b>\$1,494,789</b>



**Eliada Foundation, Inc.**  
**Statement of Activities**  
July 1, 2008 - June 30, 2009

<b>REVENUE</b>		2009	2008
	Grants and Gifts	\$644,246	\$797,496
	Rental Income	\$199,572	\$190,392
	Special Events	\$71,287	\$71,718
	Investment Income	(\$12,244)	\$86,373
	Unrealized Profit/Loss on Investments	(\$433,231)	(\$209,712)
	<b>TOTAL REVENUE</b>	<b>\$469,630</b>	<b>\$936,267</b>

<b>EXPENSES</b>		2009	2008
	Development	\$408,268	\$373,098
	Scholarships	\$5,105	\$8,889
	Grants to Eliada Homes	\$45,280	\$593,961
	Depreciation	\$197,161	\$180,753
	<b>TOTAL EXPENSES</b>	<b>\$655,814</b>	<b>\$1,156,701</b>
	<b>PROFIT/(LOSS)</b>	<b>-\$186,184</b>	<b>-\$220,434</b>
	<b>NET ASSETS</b>	<b>\$10,745,762</b>	<b>\$10,931,946</b>

Eliada Foundation is a not-for-profit corporation that exists and operates exclusively to support Eliada Homes, Inc. in the mission of Helping Children Succeed. The Board of Directors for Eliada Foundation is charged with the management of the physical plant comprising the campus of Eliada Homes. Additionally, the Board is responsible for capital development of Eliada Homes through securing funding for operational and capital needs and by safeguarding existing assets.

**Eliada Foundation, Inc.**  
**Statement of Financial Position**  
June 30, 2009

<b>ASSETS</b>		2009	2008
Cash		\$511,426	\$155,740
Accounts Receivable		\$13,856	\$7,773
Investments		\$1,814,881	\$2,261,245
Pledge Receivable		\$34,869	\$347,619
Prepaid Expenses		\$8,214	\$0
Prepaid Marketing Material		\$0	\$1,368
Utility Deposit		\$3,500	\$0
Property & Equipment		\$8,371,513	\$8,191,266
<b>TOTAL ASSETS</b>		<b>\$10,758,259</b>	<b>\$10,965,011</b>

<b>LIABILITIES</b>		2009	2008
Accounts Payable		\$6,820	\$19,148
Payroll Liabilities		\$5,029	\$0
Accounts Payable to Eliada Homes, Inc.		\$648	\$13,917
<b>TOTAL LIABILITIES</b>		<b>\$12,497</b>	<b>\$33,065</b>
<b>FUND BALANCE</b>			
Unrestricted		\$9,600,080	\$9,962,427
Temporarily Restricted		\$295,595	\$119,432
Permanently Restricted		\$850,087	\$850,087
<b>TOTAL NET ASSETS</b>		<b>\$10,745,762</b>	<b>\$10,931,946</b>
<b>TOTAL LIABILITIES &amp; FUND BALANCE</b>		<b>\$10,758,259</b>	<b>\$10,965,011</b>

<b>CONSOLIDATED NET ASSETS</b>		2009	2008
<b>ELIADA HOMES &amp; ELIADA FOUNDATION</b>		<b>\$11,614,498</b>	<b>\$11,734,758</b>

## Five Year Trends Eliada Homes & Eliada Foundation (Consolidated)

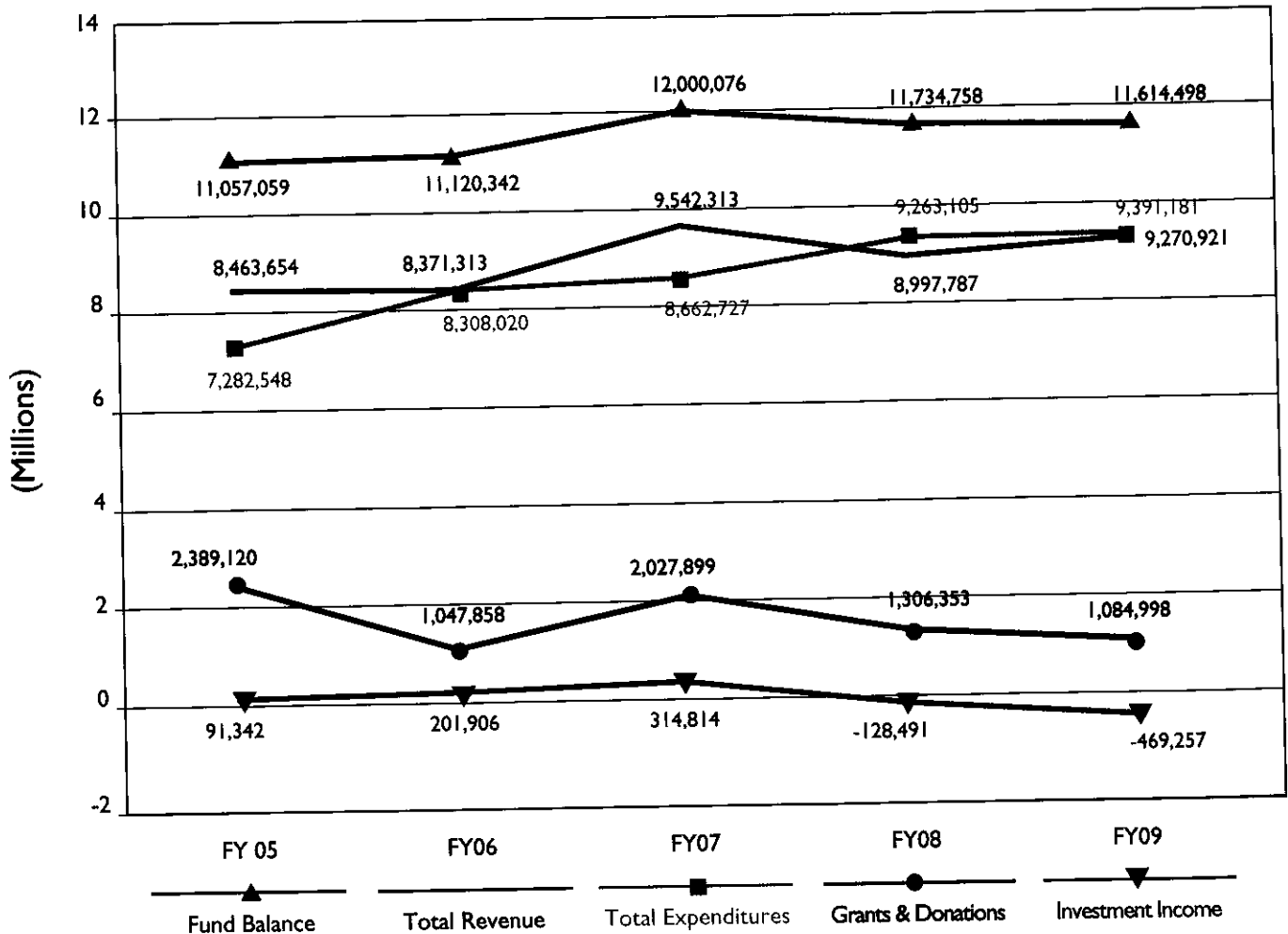

Over the past five years, Eliada has achieved remarkable growth and stability. Even during the recession of the past two years, our fund balance has remained favorable and our total revenue was not drastically affected. Major changes, however, can be seen in our investment income and, to a lesser extent, our donations. Eliada is well poised to meet the financial challenges posed by the realization of goals within the most recent strategic plan, and looking forward to a rebounding of investment income and a resurgence in donations through the institution of a capital campaign.

## STRATEGIC PLANNING AT ELIADA



Eliada is proud of its ability to be proactive and innovative. This is only accomplished by careful monitoring of quality and fiscal indicators, effective communication within the organization, and a continuous strategic planning mechanism to ensure optimum performance. Eliada began this organized approach in 2003 by conducting an environmental scan including surveys of students, parents, referral agencies, legislatures, school administrators, community activists, foundations, and donors. We also conducted SWOT (strengths, weaknesses, opportunities & threats) analyses for each of our program services. We developed quality and financial objectives and reviewed Eliada's position as a provider of quality services in North Carolina.

Once this process was completed the Senior Management and Board of Trustees met for a two day retreat to review this information and develop short and long term goals for Eliada. After just two years into that strategic plan (2003 – 2006), Eliada had accomplished 98% of the identified goals. The agency achieved a new level of financial stability through the development of managerial tools, policies, and procedures.

In 2006, Eliada began the second strategic planning process. This strategic plan focused on the organizational culture and how we would perform our services as an agency. The team reaffirmed Eliada's mission and vision statements and developed

Core Values: Faith, Hope & Love, Excellence, Teamwork, & Integrity. These values became the foundation upon which staff and board members are recruited, trained, and hired. They help us identify quality candidates, wrestle with tough decisions, and unify us in our quest to create the optimal learning environment.

Along with the identification of core values, the 2006 strategic plan also outlined 36 new objectives and initiatives. Again, over 95% of the objectives identified have been completed to date; a true testament to the power of strategic planning.

Our most recent strategic plan focuses on the direction Eliada will take over the coming decades. What programs will we expand? What new initiatives will we consider? Who should we serve? How should we respond to community need? These are just a few of the questions the strategic planning process answered.

At the end of the planning process, we had more than a plan; we had a vision. The coming pages will outline Eliada's 20 year vision, including bold new ideas to serve children and families in completely innovative ways. We invite you to be a part of this exciting time in Eliada's history, as we realign our programming toward the next century of Helping Children Succeed.



STRATEGIC PLAN  
&  
20 YEAR VISION

## **20 YEAR VISION:**

Eliada is a community of highly integrated educational, treatment and character development programs for children, families and the greater community, utilizing horizontal and vertical integration to achieve its mission.

### **SHORT-TERM OBJECTIVES**

Convert to new Medicaid service definitions for day treatment, therapeutic family services and case management.

Feasibility Study: Add Substance Abuse Treatment to Eliada's continuum of care. Implement if all criteria are satisfied.

Feasibility Study: Add therapeutic family services in homes owned by Eliada adjacent to the campus. Implement if all criteria are satisfied.

Write the Eliada Model, including specific behavioral models for each treatment unit. Incorporate evidence based practices and interventions in all services.

Create the optimal mix, size, and viability of treatment services within the Critical Access Behavioral Health Agency (CABHA).

Develop and implement expanded therapeutic based vocational, animal, horticultural, recreational, and other curriculum options to promote success in treatment for the diversity of children referred to Eliada's Mental Health Services.



Longitudinal tracking of students for 10 years after leaving Eliada's services.

Develop computerized student goal tracking and feedback loop that students use to track their own progress.

Virtual Goal Coach for Students - Utilizing Artificial Intelligence, internet and "bot" technology, the virtual goal coach would be developed for a specific student's goals to track progress and provide guidance and encouragement for the student. Supplement to existing staff involvement.

Expand After-School Services by increasing PARC enrollment by 30 students.

Develop early interventions services to address:

- Learning Delays & Disabilities
- Physical Disabilities
- Autism
- Hyperkinetic and Behavioral Disorder
- Post Traumatic Stress, Neglect and Abuse

## Establishing a Vocational Program at Eliada



One of the most ambitious and forward-thinking goals outlined in Eliada's most recent strategic plan is the formation of a new vocational school for youth transitioning from the mental health or social service systems.

Organizations like Eliada have long been troubled by the startling long-term outcomes for youth who transition from foster care or residential care to adulthood. Unequipped for success in the real world, these young people are at extreme risk for homelessness, incarceration, substance abuse, and lifelong dependence on social services.

Realizing that skill development was a critically important component of tackling this challenge, Eliada began an aggressive independent living program in 2003. This series of classes and community field trips taught young people how to open a bank account, access medical care, apply for college, and much more. In addition, we began heavily promoting Eliada Foundation scholarships to youth who were ready to begin college.

Surprisingly, very few students ever took advantage of the scholarship opportunity, and those that did often floundered when given the ultimate freedom and lack of structure that typifies the collegiate experience. We realized that more needed to be done to ensure these young people didn't fall through the cracks.

Now, we are in the early stages of launching a vocational program specifically tailored to these youth. The program will offer a bridge to adulthood

and provide structure and support to youth who may not have an adult in their lives to turn to for help. Best of all, students will walk away from the program with an associate's degree in an applied trade, giving them real-world skills and opportunities to become truly self-sufficient.

This is an innovative program unlike any other in North Carolina, and we hope it will be a model for other organizations to follow in piloting similar initiatives. Preliminary thoughts on curriculum offerings include food tech, HVAC, facilities management, green technology, and turfgrass management. The specific strategic goal attached to this project is as follows:

Implement plan to pursue accreditation by 2012:

- Identify Foundation(s) to fund program during accreditation period of 1.5 years;
- Develop educational/trades program of study;
- Identify 8 initial students for the program;
- Address housing needs;
- Hire/train staff;
- Goal: Full accreditation and trades program that can be funded completely by Pell Grants, Social Security, and foster care funds;
- Identify and determine other trades to incorporate after accreditation is achieved.

## **20 YEAR VISION:**

Eliada breaks the cycles that prevent children and their families from succeeding.



### SHORT-TERM OBJECTIVES

Feasibility study/needs assessment: adding Adoption Services to Eliada's continuum of care.

Feasibility study/needs assessment: add outpatient and community-based Substance Abuse services to Eliada's continuum of care. Implement if all criteria are satisfied.

Implement and expand array of services for families of children in treatment, including:

- Parent & Sibling Support Groups
- Parent Training Classes
- Multi-Family Therapy
- Financial and Legal Counseling

Eliada will increase the intensity in which it works with families. Focus on family clarification, reunification, and permanency.

Development of effective aftercare services to ensure continued success for our students and families.

Develop family access to electronics to track student progress; Parent training customized for each family from a library of trainings delivered via internet.

Parent Partnership- Provide expanded parent teacher conferences, parent volunteers, parenting classes, parent support groups and Parent Advisory Committee.

Research and develop funding (grants) to provide services to families:

- Legal, Financial & Housing Counseling
- Immigration Assistance
- Language and GED Courses
- Identification and linkage to Social Services.



## Strengthening Family Partnerships

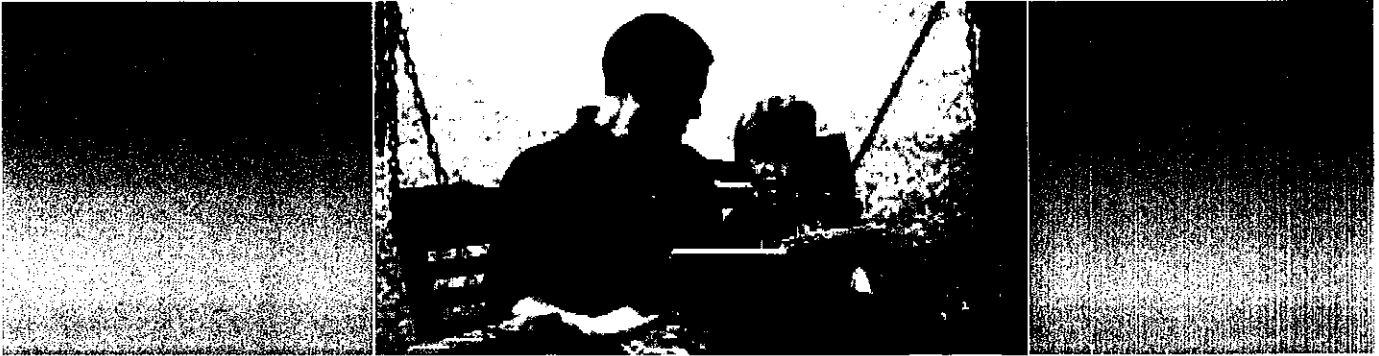

Longitudinal studies show family involvement is a direct corollary of student success. At Eliada, our role is to provide families with the tools, skills, and other resources to work in partnership towards their child's treatment goals.

Last year, we began a new initiative designed to encourage family involvement from the first day of admission. Families sign an agreement stating the expectations for them in their child's treatment process. Participation in meetings, therapy sessions and therapeutic contact with their child is essential to the process. This effort was successful in our residential services and saw 90% of families participating in treatment. The agreement is now being used in foster care and day treatment.

Now, in our new strategic plan, we are taking our commitment to family involvement to a whole new level. By offering educational programs, parenting classes, and support groups for parents and siblings, we hope to help families create a community network they can draw on for support.

In the coming years, student goals will be tracked using an electronic system accessible through a secure website. At any time, parents will be able to chart their child's progress, dialogue with their child's case manager or therapist, and learn about their child's successes and challenges. Parents will also be able to access a library of trainings, lectures, and resources to help them prepare for their child's transition home.

We will offer specialized parent trainings on the Eliada Model of care in the hopes of sustaining continuity after a child leaves Eliada. Families will be invited to participate in therapeutic recreation opportunities with their children, creating bonding experiences and offering opportunities for therapists and staff to demonstrate the Eliada Model in action.

Better transitioning planning will be supported by creating an environment in which families can openly examine their strengths and challenges. We plan to implement a standardized assessment tool to measure family communication which can be used in therapy sessions. We will construct an observation space for clinicians and will train therapists in an evidenced-based treatment focusing on changing parent-child interaction patterns. Practicing skills learned in family therapy and in our treatment services during weekends at home will be part of the process.

Many of the families we serve are challenged by outside issues that, while they deeply impact our students, have heretofore been outside of our service area. Legal problems, financial literacy, housing issues, immigration challenges, and health problems are just a few of the many things that can impact family situations. Eliada plans to train staff members to help parents access specialized resources and work through individual challenges.

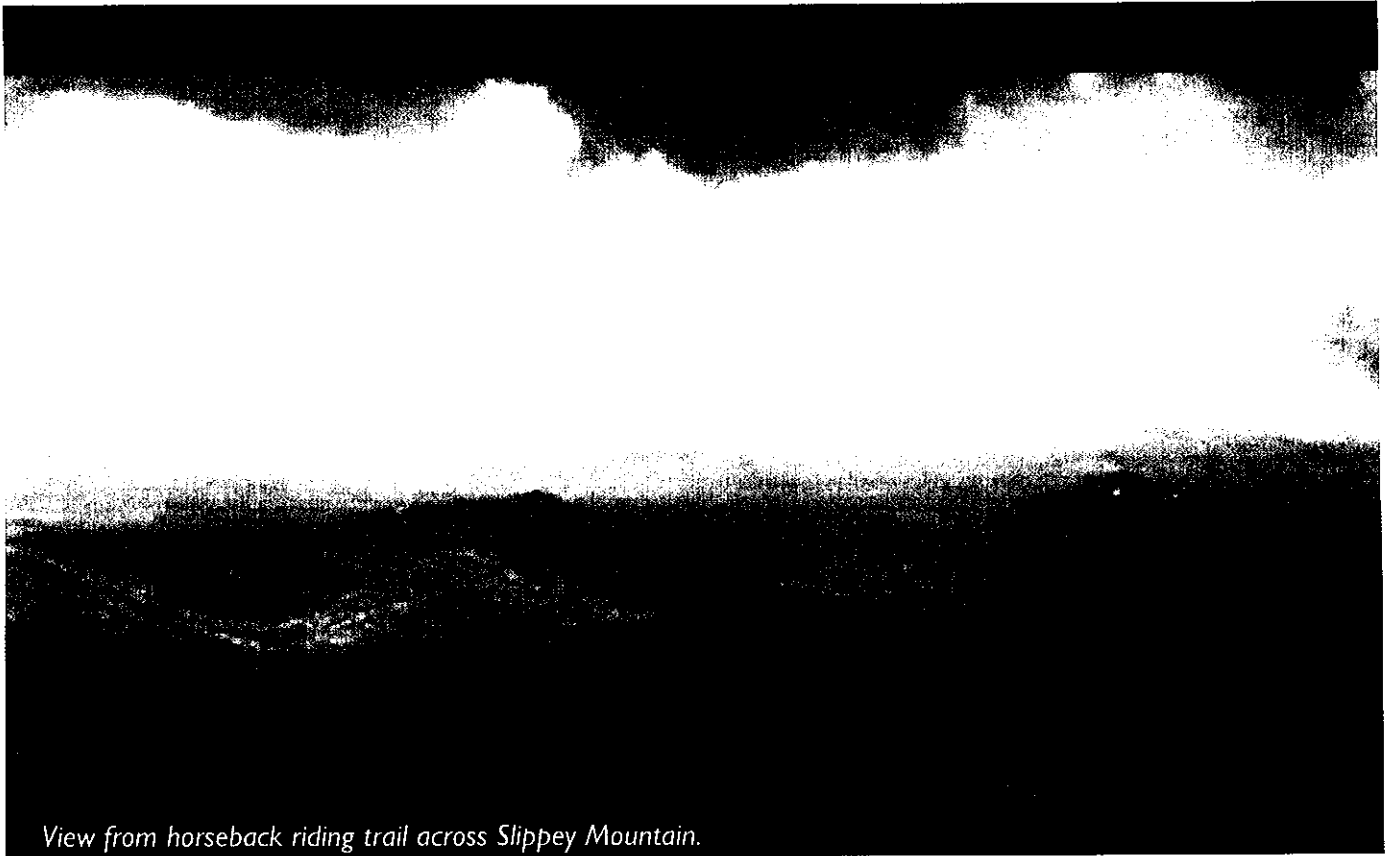

*View from horseback riding trail across Slippy Mountain.*

## **20 YEAR VISION:**

**Eliada is an extremely beautiful environment where architecture, art, nature, and functionality are intertwined.**

## **SHORT-TERM OBJECTIVES**

Facility committee will create a 10 year capital budget for improvements/maintenance of existing facilities.

Access utilization for all facilities and determine future needs for Eliada. Work with Eliada Foundation to develop a master construction plan. Develop a successful capital campaign to fund master plan.

Feasibility study: increase housing for staff on campus. Explore linkage with Mountain Opportunity Housing utilizing Compton Place and Wind Ridge.

Create optimal fitness & recreation center in the historic dairy barn. Complete rehab of roof & exterior walls. New HVAC systems. Fitness area with weight room, aerobics & climbing walls.

Construct a full challenge course with low and high ropes, zip line and repelling walls for use with students, family and staff teams.

Feasibility: Build a multi-purpose facility to house a training center, meeting rooms, administration and development offices.

Feasibility: Construct a chapel for agency and public usage on the top of Slippy Mountain.

## A Master Plan for the Future



At Eliada, our vision statement is to create the optimal learning environment that empowers children and their families to succeed. We believe in the importance of creating an environment that not only honors the children in our care, but gives students a feeling of pride in being a part of Eliada's campus.

With an eye toward sustainability, we take pride in our continual efforts to renew aging facilities. Allred, home of Eliada Academy, is on the National Register of Historic Places. Health inspections of our cafeteria and student cottages return scores of 100%, which is a testament to the immense importance we place on maintaining high standards for our physical plant.

Over the past seven years, Eliada has invested nearly two million dollars in capital improvements. This investment was absolutely necessary to bring our century-old campus to a level that illustrated our core value of "Excellence." Now, as we embark on the realization of the agency's twenty year vision, Eliada is taking this focus on environmental enhancement to a new level.

Our twenty year vision provides for the development of a plan for unprecedented environmental enhancements. This "master plan" will endeavor to make the best possible use of our existing facilities and identify construction or renovation projects that will be supportive to our success. The end product will be the creation of a

campus environment that our students, staff, and community can truly be proud of.

The first phase in the creation of the master plan will be to contract with an architect and/or organizational development consultant. Working with leadership staff and the facilities committee of the Board of Trustees, this consultant will use our twenty year vision as a template for creating a plan that provides full utilization of Eliada's 200-acre campus.

Clearly, the implementation of the master plan will require a significant investment of time and resources, not just on the part of Eliada, but for the community as well. The second phase in the master plan process is the successful development of capital campaigns to secure the financial elements.

This is an exciting time to be a part of Eliada, and all of us have something unique to contribute to the twenty year vision. In the coming months, look for more information on opportunities to become involved.



## **20 YEAR VISION:**

Eliada has highly skilled staff who find their work rewarding.

## **SHORT-TERM OBJECTIVES**

Expand training options for experienced treatment staff and foster parents.

Provide Qualified Professional training on family dynamics; group work with families and engaging resistant families in treatment.

Expand RISE program to include a residency program for professionals in their respective fields. Include accounting, human resources, and MIS. Goal of 1,000 applicants/year for RISE positions.

Develop departmental succession plan. Identify core competencies required and develop training resources to address those needs.

Develop virtual human resources specialists - utilizing artificial intelligence, internet and "bot", the virtual HR specialists could collect initial information for applicants for employment, inform supervisors of training requirements for their subordinates, and provide basic policy and practice training.

Achieve rating in the top 25% tier for wages and benefits in the market and service arena.

Develop an Enhanced Retirement Plan that would allow an employee in direct line services to retire with a secured standard of living.

## Residential Interns Seeking Excellence



The Residential Interns Seeking Excellence (RISE) program was one of the first new initiatives CEO Mark Upright brought to Eliada when he arrived in 2002. The RISE program offers new college graduates the opportunity to rotate through Eliada's core service areas, gaining valuable experience and on-the-job training. Students commit to serve for one year and in exchange receive housing including utilities, meals, and a living stipend.

All of the service areas involve direct care, working with children and adolescents who have mental health diagnoses. Rotation through the different service areas provides interns with experiences in treatment planning and implementation, documentation, family team process, case management, crisis management and permanency planning.

RISE is truly a win-win program. The students benefit from the youthful enthusiasm of RISE interns, who are able to build their resumes and learn more about human services. For Eliada, the program has saved nearly \$800,000 in staffing costs since its inception.

RISE interns are recruited through the career centers of colleges and universities, online internship placement services, and through limited regional and statewide advertising. Some RISE interns are from our local community, but Eliada has hosted RISE graduates from all over the country and across the globe. To date, RISE interns have hailed from South Africa, England, France, and Jamaica.

Roughly 40% of RISE graduates go on to positions of leadership within Eliada, and the remaining 60% leave to attend graduate school in social work and other related fields. Two RISE graduates have gone on to law school, and one is currently serving in the Federal Bureau of Investigation.

Realizing the success of the RISE program, our new strategic plan includes an ambitious expansion. We hope to open the program not just to potential human services employees, but also to those who are pursuing careers in accounting, human resources, and information systems technology.

This expansion will include the development of standardized trainings and learning opportunities for new interns, and further establish Eliada as an organization committed to training the next generation of leaders. Like our current RISE internship offerings, we anticipate that these new opportunities will be in high demand. Our goal is to create such valuable learning experiences that the volume of new applications will exceed 1,000 per year.

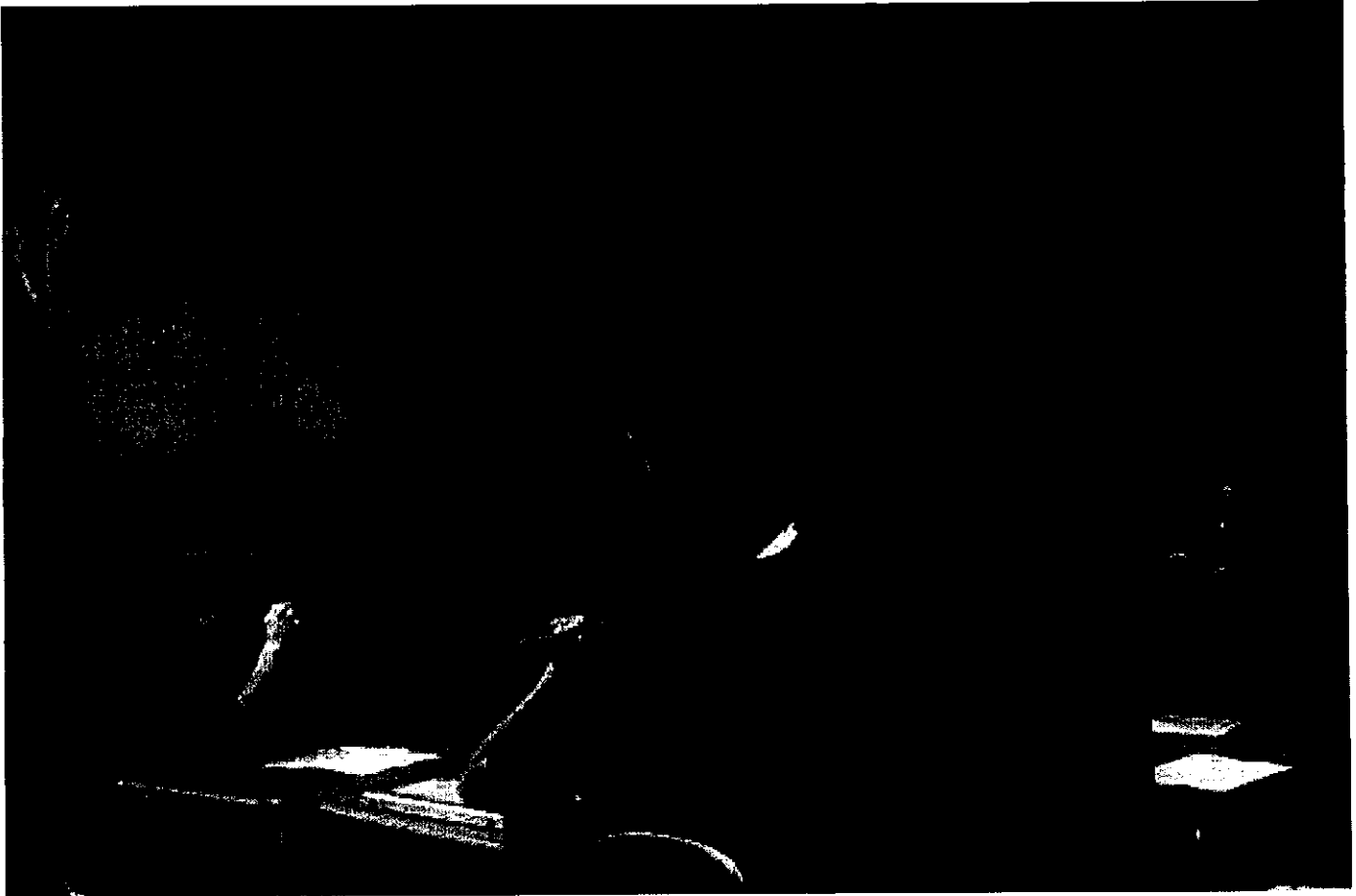

## **20 YEAR VISION:**

**Eliada extends its mission beyond our organizational boundaries.**

## **SHORT-TERM OBJECTIVES**

Develop a training series for treatment, education and management services. Market to other non-profits and children's services organizations.

Develop career planning opportunities for current employees. Identify and assist employees who desire management career tracks in obtaining knowledge and skills to pursue opportunities both inside and outside the Eliada organization.

Work extensively with State and Federal Administrative Divisions to address quality and cost effective service delivery. Introduce and advocate for a single chart of accounts, standardized allocation methodologies, and computerized variance reporting.

Develop linkages with Family and Juvenile Courts to provide preventative, treatment and educational services. Develop a Parent Coordinator Division to provide mediation services. Seek Foundation funding for judicial services.

Develop an employee incentive program to encourage community volunteerism and involvement in civic associations. Rotary, Lions, Elks, Boy Scouts, Girls Scouts, Youth Recreation leagues.

## **20 YEAR VISION:**

Eliada sustains a culture that embodies our Core Values: Faith, Hope & Love, Excellence, Teamwork, & Integrity.

### **SHORT-TERM OBJECTIVES**

Complete an employee handbook to include Eliada history, performance expectations, organizational structure and values, as well as operational guidelines. Develop hard copy as well as on-line version.

Produce an updated video to include information on each department of Eliada. Include performance expectations, attire, boundaries, interpersonal relationships and linkage between each department and Eliada as a whole.

Improve record retention system. Identify optimal placement of record archives on campus. Purge all non-required records. Develop effective and efficient document retrieval system. Develop full electronic storage system.

Computer scenario modeling for Financial/Program options.



## **20 YEAR VISION:**

Eliada is nationally recognized for its services and organizational culture.

### **SHORT-TERM OBJECTIVES**

Collect data on performance indicators and post quarterly on the webpage. Utilize this data to direct programmatic and clinical decisions and initiatives.

Present outcome results and program evaluation model at a national conference. Initiate peer review of outcomes measurements and model with agencies, foundations and research entities throughout the United States.

Publish an article in a national publication on program evaluation model.

Change Eliada Homes name to simply ELIADA. Rebrand to honor the past, but accurately depict what Eliada is today and what it is striving to become in the future.

Become a national voice for the importance of Early Brain Development. Eliada would develop a campaign that would stress the importance of a stable, supportive environment during the first 5 years of life.



## **20 YEAR VISION:**

Eliada is financially independent through endowments, benefactors, and public/private funds. Eliminate dependence on federal and state public funding.

### **SHORT-TERM OBJECTIVES**

Achieve annual revenue goal of 15 million by June.

2.5% profit margin for combined services. Annual operations profit of \$375,000.

Diversify funding streams- reduce medicaid funding percentage of total revenue from 83% to 60%.

Work with Foundation to conduct successful capital campaigns.



## Early Childhood Brain Development



New research from Harvard University confirms the paramount importance of a nurturing environment in the early stages of life. This research shows that even though we cannot remember our infancy, what we experience in our first years profoundly shapes who we are and our capacity to become healthy, happy, and successful adults.

Infants are born with a brain that is primed for learning. At birth we have as many nerve cells as stars in the Milky Way. However, these cells have not yet established a pattern of wiring between them. An infant's brain needs early experiences to wire the neural circuits of the brain that facilitate learning.

What a child experiences between the ages from birth to age 5 establishes the foundations for learning during this vital period when learning is easiest for a child. Early experience and interaction with the environment are the most critical in a child's brain development.

What children need most is loving care and new experiences. Talking, singing, playing, social interaction, and reading are some of the key activities that build a child's brain. The exchanges that caregivers assist with in a child's environment are what spur the growth and pattern of these connections in the brain.

As the synapses in a child's brain are strengthened through repeated experiences, connections and pathways are formed that structure the way a child learns. When a connection is used repeatedly in

the early years, it becomes permanent. If a pathway is not used, it's eliminated. Beginning at about age 11, a child's brain gets rid of extra connections in a process calling "pruning," gradually making order out of a thick tangle of "wires." The remaining "wiring" is more powerful and efficient. The school age years are not only years of cognitive learning while in an academic setting but also of constant social/emotional challenges.

Through consistency in quality guidance and care, school age children learn how to effectively handle these challenges. This ongoing process of learning guides children in how to cope with these challenges; building those lifelong connections and pathways in the brain that follow the child into adulthood. Furthermore, as adults they are then primed and prepared to successfully enter into the adult world of relationships, college and careers.

Our new strategic plan outlines a comprehensive outreach campaign designed to get this important message to parents, caregivers, teachers, and treatment facilities. As a national voice for the importance of early childhood brain development, Eliada will provide vital information to **Help Children Succeed** from the day they are born.

Learn more about the research and view the full text of related studies at <http://developingchild.harvard.edu>.

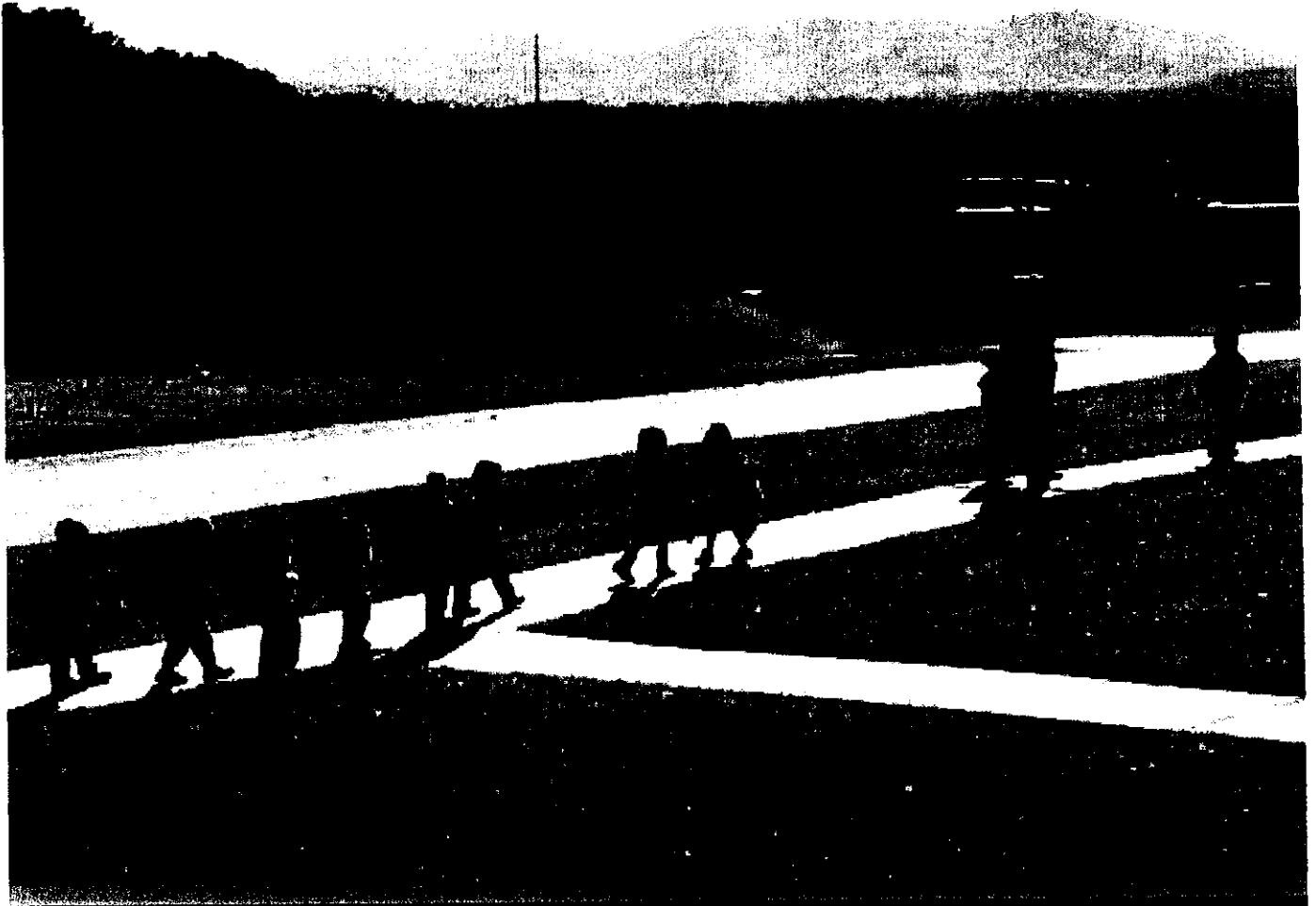

# THE 2009 COMPTON SOCIETY

The Compton Society is a distinguished group of Eliada's most faithful and generous supporters. Comprised of those that have given consecutively for five years or more and those that gave over \$1,000 in the last fiscal year, The Compton Society represents a diverse spectrum of churches, foundations, businesses, and individuals who are united in their commitment to the children and families we serve. All of us at Eliada extend our heartfelt and sincere gratitude to members of The Compton Society for their overwhelming role in fulfilling our mission:  
**Helping Children Succeed.**

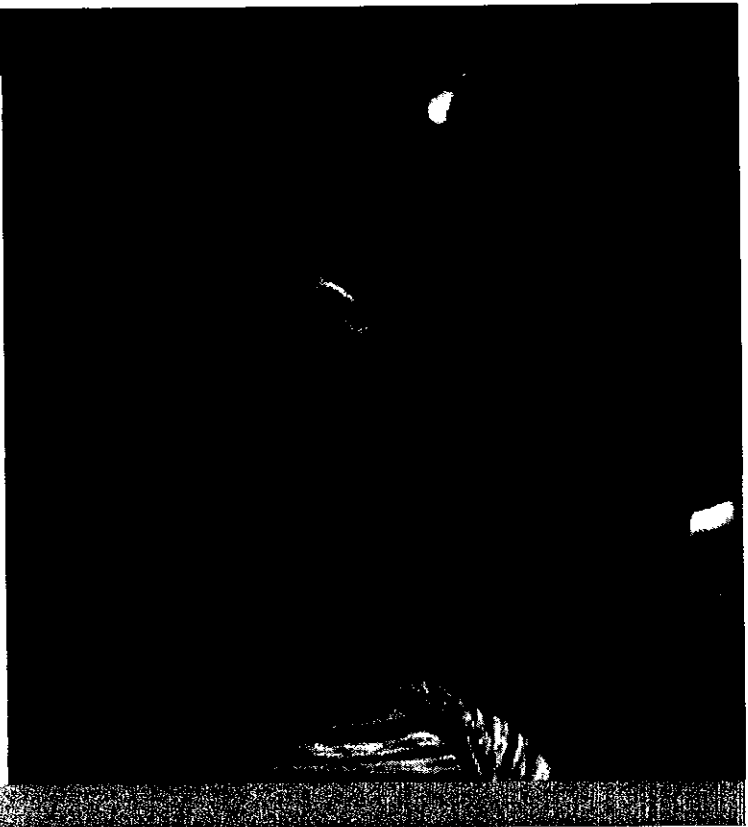

**Churches**

- Central UMC – The Martha Circle
- Central United Methodist Church
- Chestnut Grove Baptist Church
- Ebenezer Baptist Church
- Faith Missionary Baptist Church
- Hominy Valley Independent Church
- Jubilee! Community, Inc.
- Main Street Baptist Church
- Reeves Chapel UMC
- St. Eugene Church
- Walnut Presbyterian Church
- Weaverville UMC
- Woods Memorial Baptist Church

**Civic Organizations**

- Land of the Sky Bassmasters

**Foundations**

- Community Foundation of Greater Greensboro

- Community Foundation of Henderson County, Inc.
- Community Foundation of WNC
- Foundation for the Carolinas
- GE Foundation
- Janirve Foundation
- Lavendar Fund c/o Community Foundation of WNC
- Merck Partnership for Giving
- SC Johnson Fund, Inc.
- The Duke Endowment
- The Kimmel Foundation
- The Richard Eckerd Foundation, Inc.
- United Methodist Foundation of WNC, Inc.

**Businesses**

- A to Z Glass, Inc. (Wholesale Glass & Mirror)
- B&B Tobacconists
- Bank of America Matching Gifts Program

- Beverly-Hanks South
- BI-LO, Inc.
- Blossman Propane Gas & Appliance
- BlueCross BlueShield
- Brown & Brown of Lehigh Valley, Inc.
- Carolina CAT
- Carolina First
- Comprehensive Chiropractic
- Davis Technologies LLC
- Deltec Homes
- Earth Fare
- GDS, Inc.
- Grain and Salt Society
- Great Smokies Medical Center
- Hendersonville Printing & Mailing
- Judy's Professional Cleaning Service
- Lewis Real Estate
- Mailman Mail Management Services

McClain Enterprises  
Michigan Land Syndicate  
Mill End Enterprises, Inc.  
Music City of Asheville  
Pearlman's Carpet One  
Progress Energy Matching  
Gifts Program  
Progress Energy, Carolinas, Inc.  
Ruane, Cunniff & Goldfarb LLC  
Saint Gobain Abrasives, Inc.  
Southeastern Container, Inc.  
Sutherland Foundation, Inc.  
Taylor Motor Company, Inc.  
The Littlest Golfer  
The Orange Peel, LLC  
UPM Raflatac, Inc.

### **Individuals**

Mrs. Frances Allison  
Mr. & Mrs. Kenneth Allman  
Mr. & Mrs. Paul Amos  
Mr. & Mrs. Walter Andersen  
Mr. & Mrs. James Andersen  
Mr. Marshall Anderson  
Mr. Will Annarino  
Mr. & Mrs. Fred Ayers  
Mrs. Corajean Barrett  
Mrs. Pearl Black  
Mr. & Mrs. Fred Black  
Mrs. Madeline Blom  
Mr. & Mrs. Roger Boone  
Mr. & Mrs. Charles Boyd  
Mr. & Mrs. E.C. Bradley  
Mr. & Mrs. William Briggs  
Mr. William Brothers  
Ms. Bernice Brown  
Mrs. Merton Brown  
Mr. James Browning  
Mrs. Nina Bumgarner  
Mr. & Mrs. Thomas Bumgarner  
Mrs. Erwin Burhoe  
Dr. Larry Cabe  
Mr. & Mrs. Joseph Canfield

Mr. & Mrs. William Cannon  
Mr. Avery Carpenter  
Judy Carter & Susan Sluyter  
Mr. & Mrs. Carroll Case  
Mr. & Mrs. James Chapman  
Mrs. Sandra Cheek  
Dr. & Mrs. Kenneth Clark  
Mr. Melvin Clark  
Mrs. Isabel Cole  
Mr. & Mrs. Ralph Conlon  
Mr. & Mrs. Thomas Cook  
Mrs. Mary Louise Corn  
Mr. & Mrs. Wayne Coulter  
Mr. Joseph Coyle  
Mr. Wiley Crook  
Ms. Eugenia Cross  
Mr. & Mrs. Thomas Davidson  
Mr. C. Richard Davis  
Mrs. Joan DeLucca  
Mr. & Mrs. Chuck Deyton  
Ms. Brenda Dillingham  
Mrs. Karen Donatelli  
Ms. Esther Dycus  
Ms. Thelma Dyer  
Ms. JoAnn Ebbs  
Ms. Hope Edick  
Mr. & Mrs. Thomas Edwards  
Mr. & Mrs. Joe El-Khouri  
Mr. James Ellis  
Mr. Charles Epley  
Mr. Albert Estes  
Mr. Micheal Farlow  
Mr. & Mrs. Robert Finney  
Ms. Marjorie Foster  
Mr. Charles Frady  
Mrs. Helen Franklin  
Mr. & Mrs. Harold Friend  
Mr. Lee Galloway  
Mr. Henry Gasperson  
Mr. & Mrs. James Gillespie  
Mr. Donald Glover  
Dr. & Mrs. Ronald Godbold  
Mrs. Shirley Gonce  
Mr. Gregory Goodman  
Ms. Rachel Gordon

Mr. & Mrs. Allen Greer  
Mrs. Irene Greer  
Mr. & Mrs. Clarence Griffin  
Mr. & Mrs. Rick Gross  
Ms. Laura Grover  
Ms. Deborah Gunter  
Mr. & Mrs. Edward Hahn  
Mrs. Hattie Hailey  
Mr. & Mrs. Donald Hall  
Mr. & Mrs. Richard Haring  
Mr. & Mrs. David Harrell  
Mr. & Mrs. Brice Harris  
Mr. & Mrs. Stephen Harris  
Ms. Ruby Haynes  
Mrs. Ruth Heinemann  
Mr. & Mrs. Ernest Henderson  
Mrs. Cynthia Hobbs  
Mr. & Mrs. Wayne Hoffner  
Mr. Phillip Holland  
Mr. & Mrs. Thomas Hughes  
Mr. & Mrs. Kenneth Hughes  
Ms. Elizabeth Hunter  
Mr. & Mrs. Robert Hunter  
Mr. & Mrs. Michael Huntley  
Mr. & Mrs. R.G. Imbt  
Mr. James Jarratt  
Mr. Harvey Jenkins  
Mr. Lawrence Jenkins  
Ms. Marie Jensen  
Mrs. Mary Elizabeth Jepson  
Mrs. Elsie Johnson  
Mr. & Mrs. Jerry Jolly  
Mr. & Mrs. Timothy Kelley  
Ms. Joan Kelley  
Mr. & Mrs. Ron Kilichowski  
Dr. & Mrs. Philip Kiratzis  
Mr. & Mrs. William Kisken  
Mrs. Gladys Koon  
Mr. Ralph Lambert  
Mr. & Mrs. Alan Lang  
Mr. & Mrs. Brian Langford  
Mr. & Mrs. Kenneth LaRowe  
Mrs. Audrie LaTowsky  
Mr. & Mrs. Floyd Layman  
Ms. Karen Lindsay

Mrs. Edgar Lyngholm  
Mr. David Mackintosh  
Mrs. Susan Maricle  
Mr. Duane Martin  
Mr. & Mrs. Norman Mason  
Mr. Robert Massey  
Dr. & Mrs. W.C. Mathis  
Mr. & Mrs. Hugh McCollum  
Mrs. Jean McGuire  
Ms. Tammy McIntosh  
Dr. & Mrs. Roderick McLennan  
Mr. & Mrs. Alexander McWilliam  
Mrs. Georgia Melton  
Mr. & Mrs. Bob Merrill  
Mr. Gary Mewborne  
Mr. Harry Miller  
Mr. James Miller  
Mr. & Mrs. James Mills  
Mr. Louis Mongiovi  
Mr. & Mrs. James Morgan  
Mr. Charles Morris  
Mr. James Moutos  
Mr. & Mrs. Gerard Mozian  
Mr. & Mrs. Roger Myrto  
Mr. John Nichols  
Mrs. Annie Orr  
Mr. Howard Parks  
Mr. & Mrs. Roland Parris  
Dr. & Mrs. Barry Pate  
Mrs. Milagros Payne  
Ms. Elizabeth Penn  
Mr. & Mrs. Williard Phillips  
Mr. Gus Poulos  
Mr. William Pressley  
Ms. Leslie Price  
Mr. & Mrs. David Proffitt  
Mrs. Margaret Pruitt  
Ms. Amy Pulaski Micsko  
Mr. Shantharam Ramaswamy  
Mrs. Carolyn Ramsey  
Mr. & Mrs. Roy Ramsey  
Ms. Judith Ream  
Mr. & Mrs. Joseph Reynolds  
Mr. Lawrence Riddle  
Mr. & Mrs. John Riggins

Mr. & Mrs. Gary Roberts  
Mrs. Joan Rocamora  
Judge & Mrs. Peter Roda  
Mr. Ernest Rosenau  
Mr. & Mrs. Joe Rowden  
Mr. & Mrs. Fred Russell  
Mr. & Mrs. Cesar Sastre  
Dr. Lary Schulhof  
Mrs. Beverly Schumpert  
Mr. & Mrs. Russell Scott  
Mr. R. Lee Sechler  
Mr. John Sharpe  
Mr. & Mrs. Alan Shaw  
Ms. Glenda Sheppard  
Mr. & Mrs. Charles Shook  
Ms. Elizabeth Sides  
Mr. Charles Silver  
Rev. & Mrs. Charles Sisk  
Mr. William Slawter  
Mrs. Shirley Sluder  
Mrs. Susan Smathers  
Mr. and Mrs. Ellison Smith  
Mr. William Smith  
Mr & Mrs. Michael Smith  
Mr. & Mrs. Reece Snyder  
Ms. Doris Sorrells  
Mr. & Mrs. Mike Sorrells  
Mr. Roy Spivey  
Mr. S.L. Stambaugh  
Mr. & Mrs. Hal Starnes  
Mrs. Lena Stebbins  
Dr. & Mrs. Harry Steiner  
Col. & Mrs. C.D. Strider  
Mr. & Mrs. James Suggs

Mr. Clyde Sutton  
Mr. Harry Swilling  
Mr. & Mrs. Phillip Tatler  
Dr. & Mrs. Johnny Tiller  
Mr. & Mrs. George Tipton  
Mr. Lee Towery  
Mr. & Mrs. James Trull  
Mrs. Ruth Unger  
Mr. & Mrs. Michael Upright  
Mr. & Mrs. William Voelpel  
Mr. & Mrs. Rolland Walk  
Mr. Robert Ward  
Mr. & Mrs. Boyd Warren  
Mr. Donald Watrous  
Mr. & Mrs. Raymond Weidner  
Dr. & Mrs. James Weilbaecher  
Mrs. Evelyn Weinmann  
Mr. & Mrs. Joseph Westmoreland  
Ms. Nancy Williams  
Ms. Rebecca Williams  
Ms. Pat Williams  
Mr. & Mrs. Kris Wilson  
Mrs. Bertie Wilson  
Ms. Tammi Wilson  
Ms. Virginia Wilson  
Mr. & Mrs. John Winkenwerder  
Ms. Harriette Winner  
Mr. & Mrs. James Wooten  
Mr. Reginald Young  
Ms. Virginia Young  
Mr. & Mrs. Dennis Younts  
Mr. & Mrs. Steve Zeis  
Estate of Ethel O. Anderson  
Estate of Jean Whitmire



## THANK YOU TO OUR DONORS

*This list includes those donors who have given \$100 or more in the last fiscal year (July 1, 2008 - June 30, 2009)*

### Churches

Abernethy United  
Methodist Church  
Central UMC, Covenant Class  
Central UMC, Inquirers' SSC  
Emma UMC, Good News  
Class  
First Baptist Church of  
Asheville  
Reynolds Missionary Baptist  
Church  
Walnut Free Will Baptist  
Church  
Walnut Presbyterian, Young  
Adult SSC  
Weaverville UMC

### Civic Organizations

Kiwanis Club of West  
Asheville  
Int'l. Brotherhood of  
Electrical Workers  
Land O' Sky Doll Club  
Robbinsville Lions Club  
Valley Springs Lions Club

### Foundations

Care Partners Foundation  
Sutherland Foundation

### Businesses

Advanced Business  
Equipment  
Animals R Us  
Anson Construction  
Company  
Asheville Pool & Patio  
AZPAC Match Program  
Bankers Insurance Group  
Beverly-Grant, Inc.  
Bouchon  
Boyd Mountain Log Cabins

BRS, Inc.  
Brumit Restaurant Group  
Carolina Home Exterior  
CEC Entertainment  
Clarkston Consulting  
Deal Motor Cars  
Edline  
Fidelity Brokerage Services  
Four Seasons Plumbing  
Frankie Bones  
Hampton Inn  
Hardin Chiropractic  
Jim Barkley Toyota  
Kimmel & Associates  
KOHL's  
Kuchar Tax Planning &  
Financial Services  
LabCorp  
Lifestyles Unlimited  
Marcis Auto Racing  
Mast General Store  
Mayhew Consulting Company  
Mckinney Insurance Agency  
Mechanical Equipment  
Corporation  
Meinch Construction  
Mike Byer Auto & Truck  
Repair  
Mike's on Main Street  
Mission Hospitals  
Nova Development  
Office Environments of  
Asheville  
Pearsall Operating Company  
Ray & Allen Funeral Service  
Rod Hubbard  
Sam & Dave's Auto Sales  
Smith, Kesler, and  
Company, PA  
Stanley A. Briggs Custom  
Furniture

State Employee's Credit  
Union  
Steve Fox Electric  
TDA Associates  
Teresa A. Tuers Appraisals  
The Lobster Trap  
Todd's RV & Marine  
TP Howard's Plumbing  
Company  
Wachovia Bank

### Individuals

Ms. Dawn Allen  
Mr. Ray Anders  
Mr. and Mrs. Terry  
Andersen  
Mr. and Mrs. John  
Anderson  
Ms. Carolyn Ashworth  
Mr. and Mrs. Dennis Atkins  
Mr. Michael Babb  
Mr. and Mrs. Ray Bachmann  
Mrs. Juanita Baker  
Mr. Milner Ball  
Mr. and Mrs. Harry Barnes  
Mrs. Betsey Bent  
Mr. Mike Blankenship  
Mr. and Mrs. David Bourne  
Mr. and Mrs. William Boyer  
Mr. and Mrs. Charles  
Bradley  
Dr. William Brazil  
Ms. Carol Browne  
Mr. and Mrs. William  
Buckner  
Ms. Deborah Burchfield  
Mr. and Mrs. James Burns  
Mr. and Mrs. Rowe  
Campbell  
Dr. and Mrs. William  
Campbell

Mr. and Mrs. Jimmie  
Cantrell  
Dr. David Capiello  
Mr. Kyle Carter  
Mr. William Carter  
Mrs. Judy Carver  
Mrs. Elaine Cave  
Mrs. Debra Chapman  
Mr. Robert Chason  
Mr. Peter Ciaccio  
Mr. Robert Cline  
Mr. Thomas Corbin  
Mr. Johnathan Corwin  
Ms. Ann Coxe  
Mrs. Margaret Creasman  
Dr. Denniston Crews  
Ms. Obera Currin  
Mr. Alan Cutter  
Mrs. Jeanne M. Daniel  
Mr. Gerald K. Davies  
Ms. Phyllis Delaney  
Mr. Gregory Denton  
Mr. and Mrs. Rock  
Doddridge  
Mr. and Mrs. Charles  
Dolcimascolo  
Mrs. Barbara Dougherty  
Dr. Louis Dwarshuis  
Mrs. Sue Echols  
Mr. Alfred Edye  
Ms. Janet Egan  
Mr. Charles Elmer  
Mr. and Mrs. Dave Fell  
Mr. Larry Fisher  
Ms. Julie Forbes  
Mrs. Johanna Fowler  
Mrs. Carol Freeman  
Dr. and Mrs. Robert  
Freeman  
Mr. and Mrs. Wayne  
Freeman

Mr. and Mrs. Thomas Furci  
 Mr. Paul Geoghegan  
 Mr. Matthew Godfrey  
 Mr. Timothy Goodson  
 Mr. George Goosmann  
 Mr. Henry Gregg  
 Mr. and Mrs. Timothy Griffin  
 Mr. Carl Groth  
 Mr. Robert Gunter  
 Mrs. Hector Gutierrez  
 Mr. Brian Hall  
 Ms. Sarah Hall  
 Mr. Corwith Hamill  
 Ms. Judith Hamill  
 Mr. and Mrs. Claude Harris  
 Mr. Stephen Harris  
 Mrs. Myrna Harris  
 Ms. Vivian Henson  
 Mr. and Mrs. L.R. Higdon  
 Dr. Haywood Hill  
 Mr. Donald Hinton  
 Ms. Elizabeth Hocking  
 Mr. and Mrs. Paul Holcombe  
 Mrs. Peter Holloway  
 Mrs. Lisa Hookano  
 Mr. and Mrs. Curtis Horn  
 Dr. John Hoskins  
 Mr. Leonard House  
 Ms. Sarah Hudson  
 Ms. Lynn Hull  
 Mr. and Mrs. Robert Humes  
 Mr. and Mrs. Steward Humphrey  
 Mr. and Mrs. Wes Hunt  
 Mr. James Hurley  
 Ms. Celeste James  
 Dr. Oscar Jenkins  
 Mrs. Kathryn Johnson  
 Mr. Don Jones  
 Ms. June Kerr  
 Mr. and Mrs. Paul Ketchum  
 Mr. Barry Kimble

Mr. and Mrs. Bruce Kimble  
 Mr. and Mrs. Michael Kimble  
 Mr. and Mrs. Doug King  
 Mr. and Mrs. Jon Krupnick  
 Mr. and Mrs. Joe Lasher  
 Mrs. Donna Leonard  
 Mr. and Mrs. James Lesko  
 Mr. Thomas P. Leslie  
 Mr. Benny Lewis  
 Mr. Carl Lewis  
 Judge and Mrs. Robert Lewis  
 Mr. Christopher Libertore  
 Mr. and Mrs. Michael Lilly  
 Ms. Hannah Lim  
 Mr. and Mrs. John Link  
 Mr. Karl Litten  
 Mrs. Mae Long  
 Mr. and Mrs. William Lytle  
 Ms. Leah Matthews  
 Mr. J. Nathan McCarley  
 Mr. Walter McConnell  
 Mr. and Mrs. Julian McCracken  
 Mrs. Tracey McCrain  
 Mr. and Mrs. Mike McCrary  
 Ms. Jayne McDonald  
 Mr. and Mrs. Lee McElrath  
 Mr. and Mrs. Jeff McKinney  
 Ms. Arlene McLellan  
 Ms. Sarah McMahan  
 Mr. and Mrs. William McPhaul  
 Mr. Charles Messer  
 Ms. Patricia Michales  
 Mr. F.E. Miller  
 Mr. and Mrs. Lloyd Miller  
 Mr. James Mitchell  
 Ms. Julie Modaff  
 Mr. Robert Molezzo  
 Mr. and Mrs. Coy Moore  
 Mr. Tom Morgan  
 Mr. Bill Morris  
 Mr. and Mrs. Francis Morris  
 Mr. Samuel Morris

Mrs. Cora Mundy  
 Mr. William Newman  
 Mr. William Newton  
 Ms. Susan Nilsson  
 Mr. Frank Orminski  
 Mr. and Mrs. Mitchell Osteen  
 Mr. Alan Pace  
 Dr. Jerry Parsons  
 Mr. and Mrs. Kenneth Partin  
 Mr. and Mrs. Lowell Pearlman  
 Mr. Marvin Pearlman  
 Mrs. Jane Perkins  
 Mr. Robert Perkins  
 Ms. Karen Pfozter  
 Mr. and Mrs. George Phillips  
 Ms. Martha Pierson  
 Mr. and Mrs. Richard Ponte  
 Mrs. Mary Powell  
 Mr. and Mrs. Emmett Ramsey  
 Mr. and Mrs. G. M. Randolph  
 Mr. Millard Reed  
 Miss Monte Richardson  
 Mr. and Mrs. Robert Riddle  
 Ms. Teresa Ringer  
 Mr. and Mrs. Kenneth Roberts  
 Mrs. Dorothy Robinson  
 Ms. Alicia Rocawich  
 Mr. and Mrs. John Rose  
 Mr. and Mrs. Henry Rutledge  
 Mr. and Mrs. Brian Schlegel  
 Mr. and Mrs. Ralph Schwarzkopf  
 Mr. and Mrs. Thomas Scott  
 Mr. Marvin Secrest  
 Mr. and Mrs. Edwin Sizemore  
 Mr. and Mrs. Bretney Smith  
 Mr. and Mrs. Canie Smith  
 Ms. Corena Smith



Ms. Stacy Smith  
 Mr. and Mrs. John South  
 Mrs. Ellen Starkman  
 Mrs. Margaret Storey  
 Mr. Jim Summerlin  
 Mrs. Lucinda Taylor  
 Dr. and Mrs. James Teague  
 Mr. Ted Trivette  
 Mr. and Mrs. David Upright  
 Mr. & Mrs. Mark C. Upright  
 Dr. & Mrs. Randall Vanderbeek  
 Ms. Cora Ruth Ward  
 Mrs. Debra Warfield  
 Mrs. Brenda Warren  
 Ms. Beverly Watson  
 Mr. & Mrs. Robert Webb  
 Mr. & Mrs. Kevin Westmoreland  
 Mr. & Mrs. Ken Wiig  
 Mr. & Mrs. William Wilcox  
 Mr. Elzie Wilde  
 Mr. Thomas Wilf  
 Mr. & Mrs. Corwin Williams  
 Mr. & Mrs. Dean Williams  
 Mr. John Williams  
 Mr. Michael Woody  
 Mr. David Yawars  
 Mr. Edward Younger

## AGENCY LEADERSHIP

**Mark C. Upright, J.D., M.B.A.**  
President/Chief Executive Officer  
Attorney at Law  
President, Child & Family Svcs. Association of NC

**Marie Jensen, M.S.**  
Chief Operating Officer

**Rebecca Williams**  
Chief Financial Officer

**Michelle M. Robinson, M.S.**  
Director of Development,  
Eliada Foundation

**Tracey McCrain, M.B.A.**  
Director of Child Development Services

**Dennis Hawley**  
Director of Human Resources

## MEDICAL & CLINICAL DIRECTION

**Dr. Philip Kiratzis, M.D.**  
Medical Director  
Child Psychiatrist

**Georgia Defrancia, L.C.S.W., M.S.W.**  
Clinical Director

## ELIADA HOMES BOARD OF TRUSTEES

**Jean Bauer McGuire-Chairperson**  
Assistant Professor of Nursing,  
Western Carolina University

**Kevin Westmoreland**  
Restaurant Owner, Corner Kitchen

**Gary C. Roberts- Vice Chairperson**  
Tax Director, Buncombe County

**Dennis Younts**  
Retired, Law Enforcement

**James M. Lesko - Treasurer**  
Retired, Johnson Wax

**Charles W. Smith**  
Investment Executive, Fifth-Third Bank

**Karen K. Donatelli - Secretary**  
Realtor, Beverly-Hanks & Associates

**Harriette G. Winner**  
Retired, Mission Hospital

**Stuart E. Weidie- Imm. Past Chair**  
President, Blossman Gas, Inc.

**Sally Pearlman**  
Retired, Pearlman's Carpet One

**Debora Burchfield**  
Director, Bunc. Juvenile Detention Ctr

**John O'Neal**  
General Manager, GDS

**Dr. James E. Weilbaeher**  
Retired, Orthopaedic Surgeon  
Partner, Blue Ridge Bone & Joint

**William Neeriemer**  
Senior Manager, Dixon-Hughes

**Co-Wefa Lyda**  
President, Eliada Alumni Association

**Latrella G. McElrath**  
Business Relationship Banker, Wachovia

**Kenneth R. Hunt**  
Attorney/Partner, Roberts & Stevens

## ELIADA FOUNDATION BOARD OF TRUSTEES

**Timothy A. Kelley - President**  
Partner, Dixon-Hughes, PLLC

**Executive Committee -  
Eliada Homes**

**Hugh E. McCollum - Vice President**  
Private Investment Manager

Jean Bauer McGuire

**Martin Lewis - Secretary/Treasurer**  
Commercial Realtor, Lewis Real Estate

Gary C. Roberts

James M. Lesko

Karen K. Donatelli

Stuart E. Weidie

## LICENSES & ACCREDITATIONS

Council on Accreditation  
(COA)

National Association for the  
Education of Young Children  
(NAEYC)

NC Division of Social Services

NC Division of Child  
Development: Five Star  
Childcare License

NC Division of Health Service  
Regulation

NC Division of Medical  
Assistance

NC Division of Non-Public  
Education

Southern Association of  
Colleges and Schools

Western Highlands Network:  
Corporate and Service  
Endorsement

## AFFILIATIONS

Association of Fundraising  
Professionals (AFP)

Child and Family Services  
Association of NC

Head Start

National Child Care  
Development Association

NC Center for Non-Profits

NC Foster Family Treatment  
Association

Smart Start



INSIDE:

Board Member Spotlight: Jim Lesko: Page 2

Eliada's Annual Corn Maze: Page 7

Christmas Morning at Eliada: Page 10

# VISIONS



NEWS & EVENTS FROM ELIADA: FALL/WINTER 2011



ELIADA . 2 COMPTON DRIVE . PO BOX 16708 . ASHEVILLE, NC 28806  
828.254.5356 (P) 828.259.5384 (F) WWW.ELIADA.ORG



Left: Eliada President & CEO Mark Upright pictured with students from Eliada's Child Development Center.

Dear Friends of Eliada,

I have an ambitious goal for our staff: I want to develop the ability to track students for ten years following their graduation from Eliada. I want to find out if, ten years down the line, our students felt their experience at Eliada was valuable. Beginning with longitudinal surveys to recent alumni, we are taking steps to accomplish this goal.

Recently, I received the first batch of responses from our initial survey. What our students had to say was extremely gratifying. The question was simple: "What did Eliada do that was helpful, and what skills did you learn from Eliada that you are still using today?"

Here are a few of their unedited responses:

*"They found me a home that loves me."*

*"They supported me and gave me advice about things that would help me in the future."*

*"They helped me understand that not everyone is going to hurt me."*

*"They helped me not to hurt myself."*

*"I learned how to deal with my emotions the right way instead of getting myself into things that I can't get out of."*

*"There's actually a bunch that I learned – thinking before acting; writing; and the most helpful is talking to someone."*

I am so proud to lead an organization that is making such a positive difference in the lives of children and families in need. Each of you, our friends and supporters, are a part of our success. Thanks to you, we are able to provide vital programs and services that make a meaningful and lasting impact on the most vulnerable in our society.

Thank you for being part of the Eliada family.

Sincerely,

Mark C. Upright, J.D., M.B.A.  
President/CEO  
Attorney at Law

## MEET OUR BOARD MEMBERS: JIM LESKO



Together with his wife Nancy, Jim Lesko retired to the Asheville area in 1989. An active community leader, Jim has served on the boards of the Family Services Center, Consumer Credit Counseling Services, and the Pack Place Education, Arts & Science Center. Jim has been involved with Eliada since 2002. He has

served Eliada as former Board Chairman and is currently a member of the Eliada Foundation Board of Trustees.

Eliada has benefitted from skills and knowledge Jim brought from his long career as an engineer and international executive with Johnson Wax. His focus on transparency, accountability, and improving internal operations has fundamentally shaped Eliada's organizational culture.

When he's not volunteering or spending time with his family, Jim enjoys music, amateur radio, and hiking. A Mensa member, US Air Force Veteran, and travel enthusiast, Jim is always quick with an interesting story or joke to share. His sense of humor and unique perspective are always appreciated.

Thank you, Jim, for your years of service and dedication to Eliada's mission: **Helping Children Succeed.**

## ELIADA CEO APPOINTED TO NATIONAL BOARD

Eliada CEO Mark Upright has been appointed to the board of the National Youth Project Using Minibikes (NYPUM). NYPUM is a Honda-sponsored program that serves youth by rewarding positive behaviors with the opportunity to ride a minibike. It began in California as a gang-prevention initiative and quickly spread all over the country. Eliada has administered the NYPUM program for over a decade with great success. Last year, Eliada was the host of the Southeast Regional NYPUM Rodeo.

Mr. Upright traveled to California this November to formally accept his appointment to the NYPUM board. There, he joined senior executives from American Honda and officers from other children's organizations across the country. He looks forward to using this prestigious honor to advocate for the children and adolescents Eliada serves.



*Above: NYPUM Instructor Kristy Eubanks instructs a group of Eliada students in the repair and maintenance of a minibike. Eliada students frequently point to participation in NYPUM as one of their fondest memories during their time with us.*

## UPDATE: THE ELIADA SCHOOL OF TRADE ARTS



We first told you about The Eliada School of Trade Arts, our new vocational and transitional living program, over a year ago. We are excited to say that the program is well on its way to becoming a reality!

As you know, ESTA will offer young men with a history in long-term foster care a structured path to success. Through character development, vocational education, and the experience of transitional living, ESTA graduates will be better equipped to overcome the dismal demographics that currently characterize their peer group. Long-term foster youth are at an extremely increased risk for homelessness, incarceration, early parenthood, and long-term dependence on social services. Currently, only 3% of former foster children achieve a college degree.

This winter, Eliada received a generous grant through the Duke Endowment of \$325,000 over the course of the initial two year accreditation period. After this time, the program will be fundable through a diverse host of revenue streams including Pell Grants, Department of Labor funding, Department of Education funding, and many others.

We hope to welcome our first class of students in Summer 2012. Until then, we are working dilligently to secure the remaining needed funding, hire the optimal staff members, and continue building a curriculum that will offer real hope for this group of youth in need.

If you would like to be a part of helping launch this groundbreaking program, there is still time. We are looking for business leaders in the Western North Carolina area who would be willing to serve on an advisory panel for the development of trades and character education. If you are interested, please call 828.254.5356 or email [info@eliada.org](mailto:info@eliada.org).

Our most pressing current need is funding. We have raised over 2/3 of the amount needed to fund this program for two years. With your help we can ensure that ESTA, so vitally needed in our region, will come to fruition!

## SUCCESS STORY: ALEX CHOOSES A NEW NAME

*Our Success Stories email series was created as a way to communicate with our friends and donors in an efficient, inexpensive format. Each month, we feature one of our programs and the inspiring story of a child whom the program has helped. Sign up online at [www.eliada.org](http://www.eliada.org).*

Starting the new school year brings many changes to students—new teachers, new friends, new school supplies, new clothes. For Alex Gilliam, age 12, one very big change is his new name. Last year he was James, but on July 25, 2011, he was adopted by Amos and Allison Gilliam, his therapeutic foster parents, and became Alexander Justice Gilliam. Alex chose to take a new full name to represent this new beginning. Amos and Allison already have two young daughters, who have Biblical names for first names and middle names that are attributes of God so Alex chose Alexander, which means defender of men, and Justice as his middle name.

This new beginning is quite a success for Alex and for the Gilliam family. Amos and Allison have been therapeutic foster parents with Eliada for two years. They had an interest in fostering with a goal of adoption to provide permanence especially for an older child. Allison has a brother who was adopted, and her work at DSS also informed her decision to foster and adopt. Amos had experience working with children in a camp setting. Amos was also a full time father providing care to their daughters, Maggie and Naomi.

When Alex came to live with Amos and Allison last October, he had been in the custody of the Cherokee County DSS for six years and had experienced many placements. Adjusting to a new family, new school, and new community was not easy. Alex tested some limits and had to learn to trust again. Amos and Allison had patience and persistence and worked well with all the members of the child and family team to help Alex adjust and provide him with the stability he so needed. They provided him with opportunities to explore new interests and make friends by his participation in Boy Scouts and in church.

Alex has had an opportunity to shine as a big brother of an active three year old and a one year old. He now says, "I love being a big brother." He demonstrates his caring and compassion in helping his father, Amos, care for them. Alex's DSS social worker, David Layfield, hasn't been surprised by how easily Alex took on the role of big brother. David recalls being impressed by Alex's compassion and gentleness several years ago when he was traveling with him to a new placement. David had had a dizzy spell due to medication, and Alex was kind and attentive helping him and asking if he was OK.

The Gilliams have shown the Eliada values of Faith, Hope, and Love as well as Excellence and Teamwork in helping Alex succeed. The Gilliams serve as an inspiration to others how one foster family can make a lifelong difference in the life of a child in need.



## FOCUS ON GIVING: HOMETRUST BANK

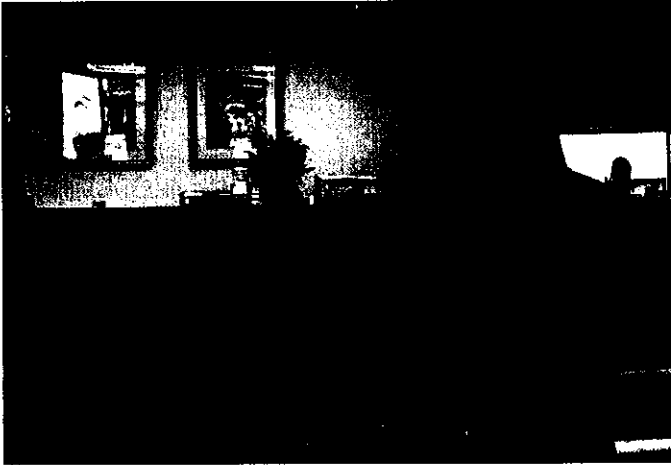

HomeTrust Bank has been a sponsor of Eliada for many years. When asked why her company supports Eliada, Franci Gasperson, Assistant Vice President and Branch Manager said "I personally feel blessed within in my own family, and very grateful to have not needed the assistance of an organization like Eliada. But to think of the many children and families throughout our community that need help and are facing challenges, and to think I could possibly play a small part in helping that child, is extremely satisfying."

HomeTrust became involved with Eliada when the Skyland Branch decided to sponsor a child for Christmas one year. Through this process, they learned more about Eliada and the children we serve. Since that time, they have sponsored events, volunteered at our annual corn maze, and stayed in touch with the needs of our students.

"As an employee of HomeTrust Bank, I strongly believe in family and community. What better way to serve our community than to focus on our children. The bank encourages employees in our individual efforts toward community involvement. I feel that by supporting and encouraging the children of today, we will be able to take pride in the adults they become in the future," says Gasperson.

Eliada wishes to thank Franci Gasperson and all the employees of HomeTrust Bank for the ongoing support of our students!

*Photos: Above, Franci Gasperson of Hometrust Bank. Opposite page, Kourtany, an Eliada Academy student, shows a handmade book to her teacher, Alice Owen.*

## CHURCH SPOTLIGHT: HOMINY VALLEY INDEPENDENT CHURCH

Hominy Valley Independent Church is proof that you don't need a big congregation to make a difference. The church has just 18 members and was founded in a basement in 1978. They moved to a garage and then another basement before building a church on a tract of land on Davis Creek Road in the Upper Hominy section of Candler. Austin Watts has been the pastor for 33 years. Church members are longtime residents of Buncombe County and have known about Eliada for years. They support Eliada because they believe it is their Christian responsibility to nurture children in need, and because they strive to have an active ministry to help meet the needs of the community. Thank you to Hominy Valley Independent Church for your support, prayers, and donations!

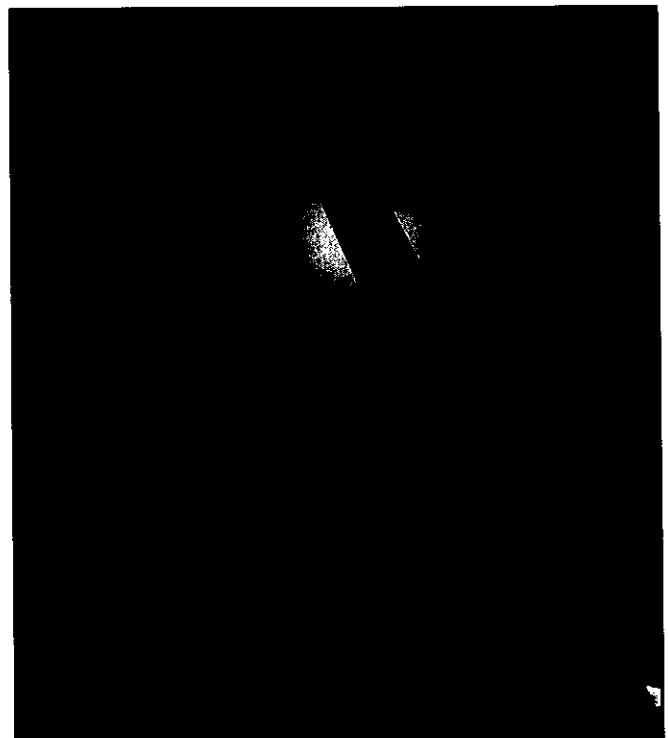

## BOOKMAKING AT ELIADA ACADEMY

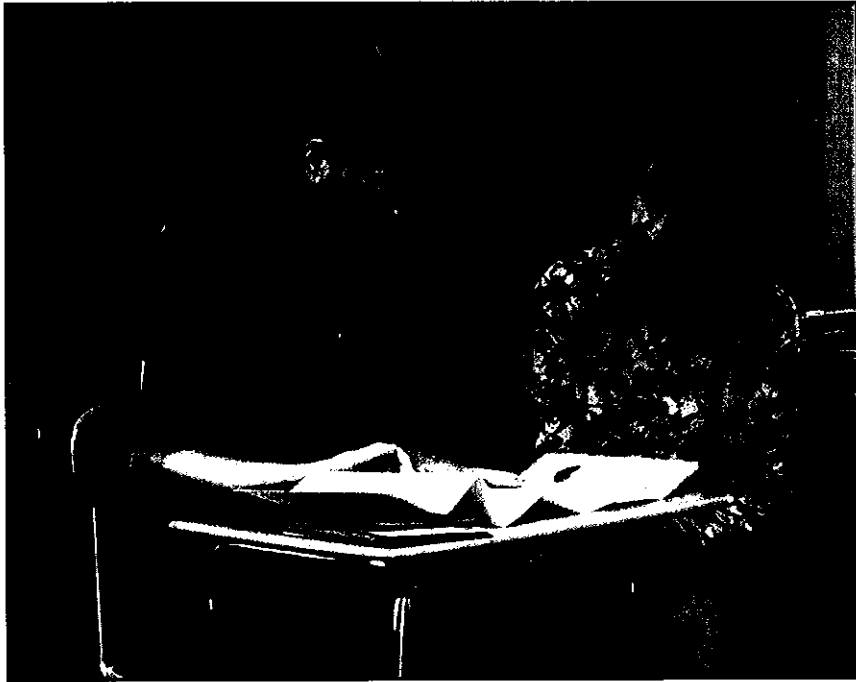

Over the last few months, students at Eliada Academy learned to make their very own books. The project started when Clarissa Sligh, who is a local artist and author, volunteered to come in and work with the students. During summer and early fall, Clarissa came weekly to teach students the art of bookmaking. She showed the students examples of her own published work and talked about the process she went through from start to finish. Each week the students had a project to complete; this meant that by the end of the class, students had each created at least five different types of books! The students were able to learn how to do stitching and binding and also how to fit together different types of books. They took photographs of their work, which they then used in a biographical book.

At the end of the project, Eliada Academy hosted an Open House that welcomed family members, other teachers, and guests to see the student books on display. Every student was able to speak at length about what they produced. It was clear that not only had they learned a lot from the work, but they also clearly enjoyed every minute of it. They were able to appropriately use technical terms for the different steps in the process. It was both educationally and therapeutically successful as the students were able to deal with frustrations as they inevitably arose. The project was also a great way to write for a specific purpose with a clear audience in mind.

We are so grateful to Clarissa for gracing us with her time and talent! On behalf of Eliada's students and staff, thank you!

## READING WISH LIST

The Giving Tree  
by Shel Silverstein

Little Women  
by Louisa May Alcott

The Wizard of Oz  
by L. Frank Baum

Any & All Titles by Dr. Seuss

The Very Hungry Caterpillar  
by Eric Carle

Goodnight Moon  
by Margaret Wise Brown

The Rainbow Fish  
by Marcus Pfister

The Polar Express  
by Chris Van Allsburg

Where the Wild Things Are  
by Maurice Sendak

Love You Forever  
by Robert N. Munsch

The Tale of Peter Rabbit  
by Beatrix Potter

Charlotte's Web  
by E.B. White

A Wrinkle in Time  
by Madeleine L'Engle

The Boxcar Children  
by Gertrude Chandler Warner

The Giver  
by Lois Lowry

# FIELDS OF FUN: ELIADA'S ANNUAL CORN MAZE

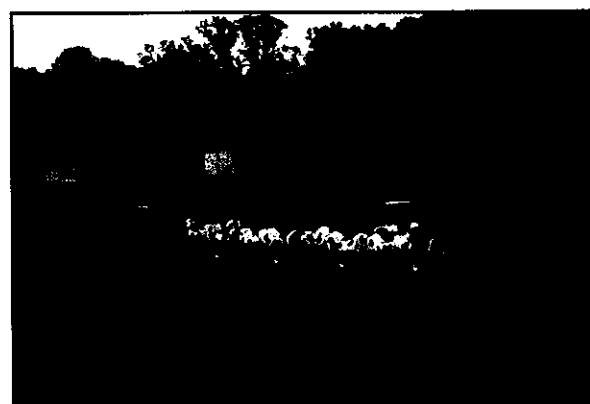
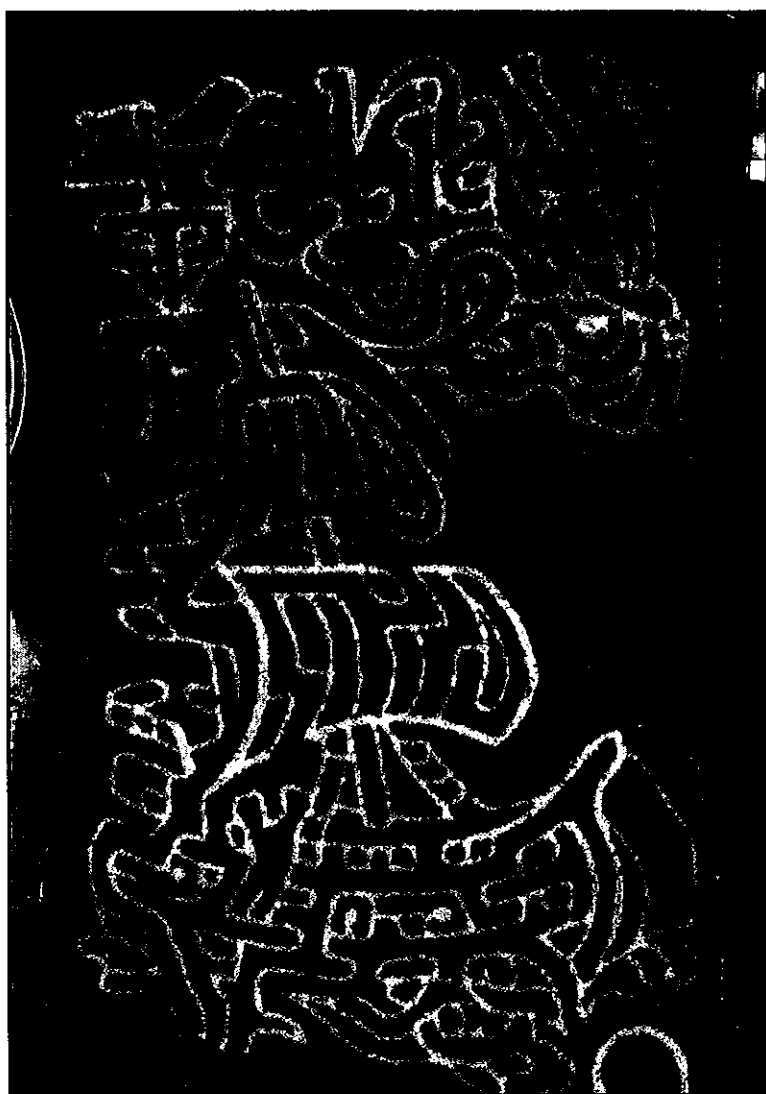

*Top Left: An aerial view of Eliada's 2011 corn maze highlighting the pirate theme; Bottom Left: Eliada's "Pumpkin Boat,"; Top Right: The Corn Box at the maze is a giant sandbox filled with corn kernels; Bottom Right: A tractor pulls the cow train through the field. The cow train is a barrel train painted to look like cows and is a favorite with small children.*



## THANK YOU TO OUR SPONSORS!

Classic Event Rental

Mazeplay

Judy's Professional Cleaning

Coca-Cola

Chick-Fil-A

TD Bank

Asheville Pool & Patio

ING

Rhodes Glass Company

The Medicine Shoppe

Parsec Financial

Brown & Brown Insurance

Control Specialties of  
Asheville

Dr. James Teague

Fifth Third Bank

Walgreens

Corner Kitchen

Aaron's

Merrimon Ave. Chiropractic

Hometruster Bank

Buncombe Co. Sherriffs

Mountain Xpress

Clear Channel of Asheville

Fairway Outdoor



## ELIADA CORN MAZE ACHIEVES NATIONAL RECOGNITION

A few months ago, Eliada's Development Department got a call from a casting agent expressing interest in Eliada's annual corn maze. Thinking it would probably turn out to be nothing, they submitted a casting tape showing the 12-acre corn maze and all of the attractions supporting it. For weeks, they heard nothing. Then, they got a phone call from an Executive Producer with HGTV.

"When they said we had been selected I couldn't believe it," said Carolyn Ashworth from Eliada's Development team. "I am so thrilled that our event and, more importantly, our agency will get to be featured in such a prominent way. I know our students will be so excited!"

The producer told Ashworth that Eliada's Annual Corn Maze would be part of a show highlighting how fall and Halloween are celebrated across the country. Filming crews will be on location at the maze sometime over the weekend just before Halloween, but the show likely won't air until next year.

Over the past three years, the maze has grown to become the largest fundraiser the agency holds. Learn more about the event at [www.fieldsoffun.org](http://www.fieldsoffun.org).

We will be sure to keep our supporters informed of the air date for Eliada's national television debut!

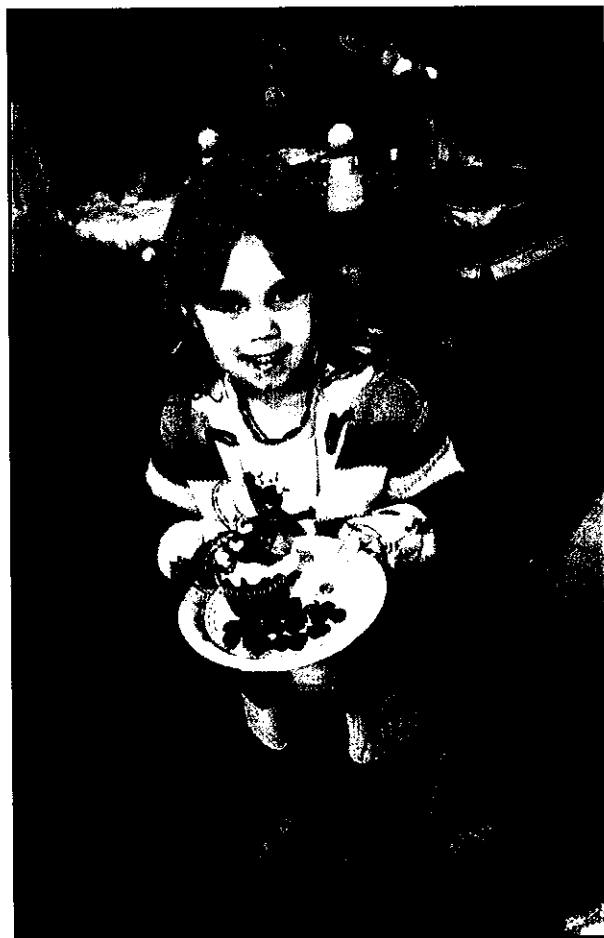

*Top: Santa reads to the children at the annual Christmas Tea at the Inn on Biltmore. Bottom Right: A local Girl Scout troop volunteers at a craft station during Eliada's annual Christmas Party for students and staff. For the past two years, the party has been facilitated by Dixon-Hughes-Goodman PLLC. Bottom Left: A young girl attending the Christmas party shows off her cupcake creation.*

## YOU CAN BE A SANTA FOR A CHILD IN NEED

**Sponsor a child.** Each year, Eliada seeks caring individuals, businesses, churches, and families to help make Christmas brighter for children in need. Sponsors can elect to give a cash gift or shop for children using "wish lists" that the children create. There are also opportunities to sponsor the cottages the children live in- for example, many of the cottages need things that all the children use, such as linens, kitchen utensils, electronics, board games, and more.

Attend the 8th Annual **Christmas Tea** at the Inn on Biltmore Estate. This year's Christmas Tea will be held December 3rd from 2:00 – 4:00 pm and will feature tea service, pastries and light fare, Dickens carolers, portraits with Santa, and much more. Tickets are \$60 and are expected to go quickly. The ticket price includes a voucher for discounted admission to Biltmore Estate. Sponsorship opportunities for the Christmas Tea are also available.

Be a part of our "**Cards for Kids**" program. This year, Eliada will offer our supporters the opportunity to buy boxed Christmas cards featuring artwork by our students. You can buy individual boxes of cards or bulk cards for your business clients. 100% of the proceeds from "Cards for Kids" go directly to our programs and services.

Give a **gift donation** in honor or memory of a loved one. This holiday season, instead of material gifts, consider giving in honor or memory of a friend or family member. Eliada will send gift donation recipients a handwritten Christmas card acknowledging your gift. Christmas cards are designed by our students and feature holiday artwork by students in our programs.

Consider a **year-end gift** to Eliada. Christmas is traditionally a season of giving. Like many nonprofits, Eliada relies heavily on these year-end gifts to sustain the many programs and services we provide throughout the year. In light of the troubled economy, Eliada's needs are greater than ever.

**Share your ideas** with us! Each year, many individuals come up with new and unique ways to help Eliada's children have a happy holiday. In the past, individuals have given stockings, donated decorated Christmas trees, and given other special gifts to the children in our care.

**For more information about any of these opportunities, contact the Eliada Development Office by calling 828.254.5356 x 300.**

"DEAR EDITOR: I am 8 years old. Some of my little friends say there is no Santa Claus. Papa says, 'If you see it in THE SUN it's so. Please tell me the truth; is there a Santa Claus?'"

"VIRGINIA O'HANLON.  
"115 WEST NINETY-FIFTH  
STREET."

"Yes, Virginia, there is a Santa Claus. He exists as certainly as love and generosity and devotion exist, and you know that they abound and give to your life its highest beauty and joy. Alas! how dreary would be the world if there were no Santa Claus... No Santa Claus! Thank God! he lives, and he lives forever. A thousand years from now, Virginia, nay, ten times ten thousand years from now, he will continue to make glad the heart of childhood."

-Francis Church, Editor of  
the New York SUN, 1897

# SHARI J. DYMCK 1968 - 2011



Recently, the Eliada family lost a valued member. Sharon "Shari" Dymock was just 43 years old when she passed away, but in her short life she made an incredible difference in the lives of others. Shari was a counselor in Eliada's residential program, where she had a special gift for working with young people in crisis. Children responded to her calm presence, her ability to listen without judgment, and her sincere love for each of them.

She is survived by her mother, Jeannine Dymock; loving partner, Joanne Ford; brother, Frederick Dymock Jr; sister, Karen Gephart; four nephews, two nieces, and many aunts, uncles, and cousins.

Shari's friends, family, colleagues, and students gathered at Eliada for a celebration of her life just a few weeks ago. They planted an apple tree in her honor and dedicated a bench just outside the cottage where she spent so many of her working hours. As their voices lifted to sing "This Little Light of Mine," it was clear that Shari's memory would live on through the many who knew and loved her. Rest in peace, Shari.

## THANK YOU TO OUR DONORS

This listing represents all contributions made beginning January 2010 through October 2010. Thank you to all of the individuals, businesses, churches, foundations, and civic clubs that make our work with children possible.

### INDIVIDUAL DONORS

Ms. Kathy Alexander	Mr. Avery F. Carpenter
Mr. Frank A. Ambrose	Mr. Max Carpenter
Mr. G. Martin Anderson	Mr. James C. Carter
Mr. Will R. Annarino	Mrs. Louis P. Caser
Dr. & Mrs. Spencer Atwater Jr.	Mr. Gerald E. Cassell
Mrs. Diane Atwood	Mr. Patrick Cavanaugh
Mr. Fred Ayers	Mr. James Chapman
Mr. Michael D. Babb	Mr. Charles R. Chapman
Mr. Richard K. Bagley	Mr. Frank K. Chapo
Lion & Mrs. Charles W. Balentine	Mr. Kenneth Chatfield
Mr. Nick Ball	Mr. Cary Christopher
Mr. Harry D. Barnes	Mr. Peter W. Ciaccio
Mr. Benjamin V. Becton	Ms. Nancy Cichowicz
Mr. Michael Benes	Mr. Melvin R. Clark
Mr. Cecil Beumer	Ms. Natalie Clark
Mr. Glenn R. Blackburn	Mrs. Raymond R. Cole
Mr. Jimmie M. Blackmon	Mrs. William W. Coleman
Ms. Faire H. Blakely	Mrs. Mary Elizabeth Compton-Jepson
Mrs. Madeline Blom	Dr. James Cook
Mr. & Mrs. Brian & Nicole Boatright	Ms. Debra Cooper
Mr. Roger L. Boone	Mr. Bob Corbin
Mr. Donald C. Boucher	Mrs. Mary Louise Corn
Mr. Charles G. Boyd	Mrs. Margaret Creasman
Mr. N. Ronald Bradford	Ms. Obera Currin
Mr. E.C. Bradley, Sr.	Mrs. Jeanne Daniel
Mr. Jerry Briggs	Mr. James W. Daniels
Ms. Marilyn Buchan	Mr. Gerald K. Davies
Mr. William Buckner	Mr. C. Richard Davis
Mr. David H. Buckner	Mr. John N. Davis Jr.
Mr. Penn J. Bullock	Mr. Thomas E. Dills
Mr. Thomas W. Bumgarner	Mr. Jack E. Ditto
Mrs. Dottie Burton	Mrs. Nancy Diver
Ms. Barbara Burton	Ms. Karen Donatelli
Mr. Larry Cabe	Mr. Wilburn Dotson
Dr. A. Barry Campbell	Mrs. Catherine Douglass
Mr. Nathaniel E. Cannady, Jr.	Mr. Charles Dowis
	Dr. & Mrs. George C. Duncan
	Mr. Chuck Durand

Mr & Mrs. William Early  
 Ms. Hope E. Edick  
 Ms. Janet Egan  
 Mr. Rudolph M. Ekstein  
 Mr. James Ellis  
 Dr. & Mrs. Miles Elmore  
 Ms. Joan L. Englishman  
 Mr. Charles W. Epley  
 Mrs. Doris Exner  
 Mr. Michael D. Farlow  
 Mr. Robert Earl Finney  
 Ms. Barbara B. Fisher  
 Mr. Randy Foote  
 Ms. Nancy C. Fowler  
 Mr. Charles W. Frady  
 Dr. & Mrs. Robert Steven Freeman  
 Ms. Melissa Freeman  
 Mr. Harold B. Friend  
 Mr. Lee Galloway  
 Ms. Barbara Gargiulo  
 Mr. Henry A. Gasperson  
 Ms. Sharon Penley Gee  
 Mr. Roscoe Gentry  
 Mr. James J. Gillespie  
 Mr. Donald J. Glover  
 Dr. & Mrs. Ronald L. Godbold  
 Mr. Mr. Matthew Godfrey  
 Dr. & Mrs. Joel W. Goldsby III  
 Mr. Jesse Goode  
 Ms. Alida J. Grady  
 Mr. Buster H. Greene  
 Mr. John Gregg  
 Ms. Laura H. Grover

Ms. Deborah K. Gunter  
 Mrs. Betty Haas  
 Mr. Donald R. Hall  
 Ms. Reita Hall  
 Ms. Sarah L. Hall  
 Mr. Corwith Hamill  
 Mrs. Ernest A. Hamill  
 Ms. Judith Hamill  
 Ms. Marguerite Hamrick  
 Mr. Frank E. Hare  
 Mr. Richard H. Haring  
 Mr. Stewart Dean Harkleroad  
 Ms. Lara L. Harrington  
 Mr. Brice C. Harris  
 Mr. Claude M. Harris  
 Mr. Gary Harris  
 Mr. Forrest Hart  
 Mr. William C. Haynes  
 Ms. Ruby B. Haynes  
 Mrs. Co-Wefa Haynes-Lyda  
 Dr. John L. Hazlehurst  
 Mr. Ernest Henderson  
 Mr. Trent D. Henry  
 Ms. Vivian Henson  
 Ms. Claire B. Hill  
 Dr. Haywood N. Hill Jr.  
 Mr. & Mrs. Dan & Molly Hitchcock  
 Ms. Amy E. Hollifield  
 Ms. Janice N. Hollifield  
 Mr. Kenneth Hughes  
 Mr. Thomas M. Hughes  
 Mr. Jack A. Hunnicutt  
 Mr. & Mrs. Wes Hunt  
 Ms. Elizabeth J. Hunter  
 Mr. R.G. Imbt  
 Ms. Marie Jensen  
 Mr. Carl J. Johnson  
 Mrs. Elsie S. Johnson  
 Mrs. Kathryn B. Johnson  
 Mr. Jerry A. Jolly  
 Mr. Don Jones  
 Mr. Edwin A. Juszczyk  
 Mr. George Kaltsunis  
 Mrs. Rubye F. Keever  
 Mr. & Mrs. Timothy Kelley  
 Ms. Pamela L. Kelley  
 Mr. Curtis R. Kempton  
 Mr. Gene Kent

Mr. Donald G. Kern  
 Ms. June C. Kerr  
 Mr. Bruce A. Kimble  
 Mr. Michael Kimble  
 Mr. James A. Kimmons  
 Ms. Catherine Kinser  
 Mr. & Mrs. Charles D. Kirby  
 Mr. William A. Kisken  
 Mrs. Gladys O. Koon  
 Mr. Harald H. Kowa  
 Mr. Charles J. Krug  
 Mr. Fred Kurfees  
 Mrs. Anthony Kushigan  
 Mr. John P. Kuzma  
 Mr. Ralph Lambert  
 Mr. Peter R. Lawson  
 Mr. Richard F. Layman  
 Mr. Glenn Leatherwood  
 Ms. Laura Legg  
 Mrs. Donna S. Leonard  
 Ms. Karen Lindsay  
 Mr. John D. Link  
 Mr. Karl Litten  
 Ms. Sandy Lundblad  
 Ms. Rita K. Lyda  
 Mrs. Edgar Lyngholm  
 Mr. Martin M. Lytle  
 Mr. David R. Mackintosh  
 Mrs. Lois Macks  
 Mr. Lee R. Major  
 Mrs. Ann Mallard  
 Mr. Dominic Mariut  
 Ms. Marcia T. Marlowe  
 Mr. Gary Mathers  
 Mr. Tony S. Mauldin  
 Ms. Judith C. Mauney  
 Mr. Joseph D. Mayo III  
 Mr. & Mrs. Hugh E. McCollum  
 Mr. Walter S. McConnell  
 Mr. Lewis Allen McCrain  
 Mr. Mike McCrary  
 Mrs. Carole J. McDonald  
 Ms. Jayne R. McDonald  
 Mr. & Mrs. William & Latrella  
 McElrath  
 Ms. JoAnn V. McElrath  
 Mrs. Jean B. McGuire  
 Ms. Tammy McIntosh





Mr. & Mrs. Ian & Aspen McKenna  
Dr. & Mrs. Roderick McLennan  
Ms. Sarah Jaudon McMahan  
Mr. John D. McMahon  
Ms. Nancy McMullen  
Mr. Ted Meadows  
Mrs. Florence J. Means  
Ms. Nancy Medford-Wood  
Mrs. Georgia Melton  
Mr. Bob Z. Merrill  
Mrs. Hilda Metcalf  
Mr. Harley Miller  
Mr. Steve Miller  
Mr. Harry S. Miller, III  
Mr. James E. Mills  
Mr. Jack C. Minter  
Mr. Robert R. Molezzo  
Mrs. Jessica Mongiovi  
Mr. James C. Morgan  
Mr. George W. Morgan  
Mr. Frank Morris  
Mr. John P. Mulvaney  
Mrs. Cora B. Mundy  
Mrs. Elizabeth Anne Murdock  
Mr. Jack Nichols  
Ms. Linda H. Nicodemus  
Mr. Alan H. Nielsen  
Mrs. Frances O'Shields  
Mr. Robert W. Oast, Jr.  
Ms. Tina Pace  
Mrs. Phyllis E. Parker  
Mr. Roland B. Parris, Jr.  
Dr. Jerry M. Parsons  
Mrs. Milagros L. Payne  
Mr. & Mrs. Lowell R. Pearlman  
Ms. Donna L. Peck

Mr. James E. Penley  
Mr. Robert E. Perkins  
Mrs. Jane Mars Perkins  
Ms. Karen Pfozter  
Mr. George Phillips  
Ms. Darla Pinkerton  
Mrs. Larry Pittman  
Mrs. Jennifer D. Pitts  
Mr. Walter M. Plaue  
Mr. Jack Postell  
Mr. Gus Poulos  
Mr. & Mrs. G. Howard Powell  
Mrs. Mary L. Powell  
Rev. & Mrs. John J. Powell  
Mr. William R. Presley, Sr.  
Mrs. Margaret Brown Pruitt  
Mr. Andrew S. Pyle  
Mr. M.E. Quest  
Mr. Shantharam Ramswamy  
Dr. & Mrs. Lewis S. Rathbun  
Mr. Joseph C. Reynolds  
Mr. Steven R. Rice  
Miss Monte Richardson  
Mr. Howard Riddle  
Ms. Maureen Rigg  
Mr. & Mrs. Gary C. Roberts  
Mr. Guy D. Roberts  
Mrs. Joan Rocamora  
Judge & Mrs. Peter L. Roda  
Mr. Ernest J. Rosenau  
Dr. J. Richard Ross  
Mr. H. Walker Sanders  
Mr. Michael Sanders  
Ms. Sherri Schaddelee  
Mr. James A. Schuler  
Ms. Nancy Schultz  
Mr. Ralph H. Schwarzkopf  
Ms. Patricia J. Senneff  
Mr. Richard Setliff  
Dr. & Mrs. James K. Sexton  
Mr. John L. Sharpe  
T. Preston Shepherd  
Mr. Ed L. Siler  
Mr. Ricky Silver  
Mr. James S. Sluder  
Mrs. Susan Smathers  
Mr. Ben Smith  
Mr. William R. Smith

Ms. Mary P. Sneed  
Mr. Reece V. Snyder  
Mr. Mike Sorrells  
Ms. Doris P. Sorrells  
Mr. Stephen A. South  
Mr. Larry Sprinkle  
Mr. S.L. Stambaugh  
Mrs. Lena Stebbins  
Dr. & Mrs. Harry E. Steiner  
Mr. Hal F. Sterns  
Mrs. Henry W. Stevens  
Ms. Elizabeth C. Stevens  
Mrs. Margaret Storey  
Ms. Susan Briggs Strickland  
Col. & Mrs. C.D. Strider  
Ms. Donna Stringer  
Mr. Clyde C. Sutton  
Mr. Harry Swilling  
Mr. Grant J. Taibi  
Mrs. Nancy Thompson  
Dr. & Mrs. Johnny T. Tiller  
Mrs. Christine Tilley-Sellers  
Mr. George Tipton  
Mr. & Mrs. Paul & Brenda Tremoulet  
Mr. & Mrs. Ted & Debbie Trivette  
Mr. Hoke H. Turner  
Mrs. Ruth S. Unger  
Mr. David J. Upright  
Mr. Mark C. Upright  
Mr. Michael Upright  
Mr. Todd J. Van Giesen  
Ms. Linda H. Waldrep  
Mrs. Ivaleigh Walker  
Ms. Susan H. Walker  
Mr. George R. Waller

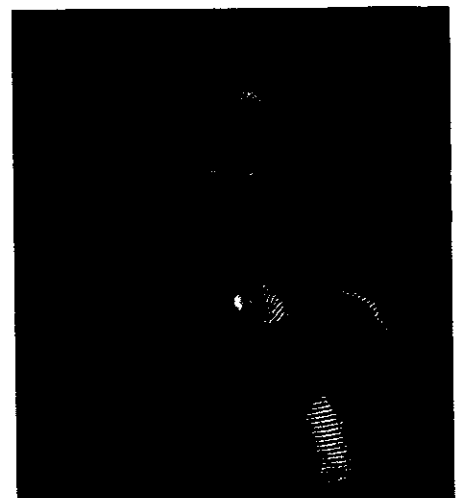

Mr. Robert L. Ward  
 Mr. Bill Ware  
 Mrs. Debra Warfield  
 Mr. Boyd R. Warren  
 Mr. Robert H. Warren  
 Mrs. Mary R. Washington  
 Ms. Beverly B. Watson  
 Ms. D. Amelia Weaver  
 Mr. Raymond G. Weidner  
 Dr. & Mrs. James Weilbaecher  
 Mr. Derek Weilbaecher  
 Mrs. Evelyn K. Weinmann  
 Mr. & Mrs. Kevin Westmoreland  
 Mr. & Mrs. Michael C. & Sara B. White  
 Mrs. Katrina R. Wigren  
 Mr. Ken Wiig  
 Mr. Charles K. Wike  
 Mr. John F. Wilborn  
 Mr. William Wilcox  
 Mr. Jerry Wilkerson  
 Mr. Corwin Williams  
 Mr. James F. Williams  
 Mr. Larry L. Williams  
 Ms. Robbie J. Williams  
 Mrs. Carmable Williams-Revels  
 Mrs. Betty H. Wilson  
 Mrs. James C. Wilson  
 Ms. Virginia R. Wilson  
 Ms. Harriette G. Winner  
 Ms. Linda Woodward  
 Mr. James D. Wooten  
 Ms. Janice Y. Wright  
 Mr. Dennis L. Younts  
 Mr. Steve E. Zeis  
 Ms. Johnnie Zorn

#### CHURCHES

Chestnut Grove Baptist Church  
 Enka Baptist Church  
 Faith Baptist Church  
 First Baptist Church  
 Francis Asbury UMC, UMM  
 Hominy Valley Independent Church  
 Morning Star UMC  
 Mud Creek Baptist Church  
 Unitarian Universalist Church  
 Weaverville UMC

#### BUSINESSES

A&M Tool Molding Division  
 Asheville Area Chamber of Commerce  
 Asheville Pool & Patio  
 AZPAC Match Program  
 Blossman Propane Gas & Appliance  
 Brown & Brown Insurance  
 Brumit Restaurant Group  
 Buncombe County Sherrif's Office  
 C&R Masonry  
 Cast Management Consultants  
 Citi-Stop  
 Classic Event Rental  
 Clear Channel of Asheville  
 Coca-Cola  
 Comprehensive Chiropractic  
 Corner Kitchen  
 Custom Exhaust & Brakes  
 Dave Anders Enterprises  
 Earth Fare  
 Fairway Outdoor  
 Fifth Third Bank  
 Four Seasons Plumbing  
 GDS  
 General Insurance Services  
 Groce Funeral Home  
 Grove Sand & Stone Company  
 Hampton Inn  
 HomeTrust Bank  
 Interstate Capital Corporation  
 Keith Hopper, DDS  
 Long, Parker, Warren & Jones PA  
 Merrimon Avenue Chiropractic  
 Mike Byer Auto & Truck Repair  
 Mountain Xpress  
 Ohlins USA  
 Parsec Financial  
 Patla, Straus, Robinson & Moore  
 Progress Energy  
 Riverside Stump Dump  
 Roberts & Stevens  
 Ruane, Cuniff & Goldfarb LLC  
 Southeastern Container  
 Southern Motors of Savannah  
 Super Lube  
 Taylor Motor Company



The Medicine Shoppe  
 The Olde Worlde Christmas Shoppe  
 Webb Insurance  
 Wells Fargo  
 Wholesale Glass & Mirror  
 William L. Chambers, DDS  
 Winston W. Pulliam Real Estate  
 Wolf Creek Engineering

#### FOUNDATIONS

The Allstate Foundation  
 Care Partners Foundation  
 The Community Foundation of Western North Carolina  
 The Community Foundation of Henderson County  
 The Duke Endowment  
 The Eblen Foundation  
 GAP Foundation  
 GE Foundation  
 Janirve Foundation  
 Merck Partnership for Giving  
 Pfizer Foundation  
 The Richard Eckerd Foundation  
 Sisters of Mercy  
 Walmart Foundation  
 Wells Fargo Foundation

#### CIVIC ORGANIZATIONS

Land of the Sky Bassmasters  
 Red Hot Mountain Mamas  
 Valley Springs Lions Club

This is a publication of Eliada Foundation, Inc., supporting Eliada Homes, Inc. in the mission of **Helping Children Succeed.**



Eliada Foundation  
P.O. Box 16708  
2 Compton Drive  
Asheville, NC 28806  
Phone 828.254.5356  
ADDRESS SERVICE REQUESTED



Financial information about this organization and a copy of its license are available from the State Solicitation Licensing Branch at 1-828-830-4989. The License is not an endorsement by the state. Florida registration number: CH-19854, 100% of contributions are received by our agency.



We are proud to present Eliada's 2010 strategic plan and twenty year vision.

The ideas and approaches outlined in this document are the culmination of over eight years' work on the part of our Board and staff. Formalized strategic planning began at Eliada in 2002, when the agency identified its mission and realigned its organizational structure to become more streamlined and financially viable. The next strategic plan in 2006 saw the definition of the agency's core values, vision, and purpose.

With this foundation, we began the strategic planning process anew in 2009/2010 with the intention of defining Eliada's focus for the coming twenty years. Many of the ideas in this strategic plan are innovative, pioneering, and bold. We hope you are as inspired by these initiatives as we are, and we invite you to be a part of this exciting new era of service. Call 828.254.5356 to learn more about ways in which you can *Help Children Succeed*.

# ELIADA

Faith, Hope & Love. Excellence. Teamwork. Integrity.

## Mission

Helping Children Succeed

## Vision

To create the optimal learning environment that empowers children and their families to succeed

## Purpose

To provide an environment in which children and their families can find their own unique gifts and strengths to reach their fullest potential

## Core Values

### FAITH, HOPE & LOVE

Eliada was founded on the principles of the Christian faith, honoring the intrinsic value and dignity of each person. We offer an environment of unconditional love and respect to encourage the development of spiritual growth and personal confidence as a foundation for achieving ones potential

### INTEGRITY

Eliada is guided by inherent honesty, ethics and accountability

### TEAMWORK

Eliada is a dedicated and diverse team of professionals who support one another in achieving the agency's mission

### EXCELLENCE

Eliada is committed to excellence in a solution-focused environment.

**20 YEAR VISION:** Eliada is an extremely beautiful environment where architecture, art, nature, and functionality are intertwined.

**20 YEAR VISION:** Eliada is a community of highly integrated educational, treatment and character development programs for children, families and the greater community, utilizing horizontal and vertical integration to achieve its mission.

Convert to new Medicaid Service Definitions for Day Treatment, Therapeutic Family Services and Case Management.

Develop computerized student goal tracking and feedback - feedback loop that students use to track their own progress.

Feasibility Study: Add Substance Abuse Residential Treatment Services. Implement if criteria are satisfied.

Virtual Goal Coach for Students - Utilizing Artificial Intelligence, internet and "bot" technology, the virtual goal coach would be developed for a specific student's goals to track progress and provide guidance and encouragement for the student. Supplement to existing staff involvement.

Feasibility Study: Add Therapeutic Family Services in homes owned by Eliada adjacent to the campus. Implement if criteria are satisfied.

Write the Eliada Model, including specific behavioral models for each treatment unit. Incorporate evidence based practices and interventions in all services.

Expand After-School Services by increasing PARC enrollment by 30 students. Develop Early Interventions Services to address learning delays & disabilities, physical disabilities, autism, hyperkinetic & behavioral disorder, post-traumatic stress, neglect and abuse.

Create the optimal mix, size, and viability of treatment services within the Critical Access Behavioral Health Agency (CABHA).

Conduct feasibility study for new vocational school and pursue accreditation by 2012.

Develop and implement expanded therapeutic based vocational, animal, horticultural, recreational, and other curriculum options to promote success in treatment for the diversity of children referred to Eliada's Mental Health Services.

Identify Foundation(s) to fund program during accreditation period of 1.5 years. Develop educational/trades program of study. Identify 8 initial students for the program, address housing needs, & hire/train staff. Goal: Full accreditation and trades program that can be funded completely by Pell Grants, Social Security, and foster care funds. Identify and determine other trades to incorporate after accreditation is achieved.

Longitudinal tracking of students for 10 years after leaving Eliada's services.

Facility committee will create a 10 year capital budget for improvements/maintenance of existing facilities.

Access utilization for all facilities and determine future needs. Work with Eliada Foundation to develop a master construction plan and supporting capital campaign.

Feasibility study: increase housing for staff on campus. Explore linkage with Mountain Housing Opportunities.

Create optimal fitness & recreation center in the historic dairy barn. Complete rehab of roof & exterior walls. New HVAC systems. Fitness area with weight room, aerobics & climbing walls.

Construct a full challenge course with low and high ropes, zip line and repelling walls for use with students, family and staff teams.

Feasibility: Build a multi-purpose facility to house a training center, meeting rooms, administration and development offices.

Feasibility: Construct a chapel for agency and public usage on Slippy Mountain.

**20 YEAR VISION: Eliada breaks the cycles that prevent children and their families from succeeding.**

Feasibility study/needs assessment: adding Adoption Services to Eliada's continuum of care.

Feasibility study/needs assessment: add outpatient and community-based Substance Abuse services to Eliada's continuum of care. Implement if criteria are satisfied.

Implement and expand array of services for families of children in treatment, including: Parent & Sibling Support Groups, Parent Training Classes, Multi-Family Therapy, & Financial and Legal Counseling.

Eliada will increase the intensity in which it works with families. Focus on family clarification, reunification, and permanency.

Development of effective aftercare services to ensure continued success for our students and families.

Develop family access to electronics to track student progress; Parent training customized for each family from a library of trainings delivered via internet.

Parent Partnership- Provide expanded parent teacher conferences, parent volunteers, parenting classes, parent support groups and Parent Advisory Committee.

Research and develop funding (grants) to provide services to families such as Legal, Financial & Housing Counseling, Immigration Assistance, Language and GED Courses, and linkage to Social Services.

**20 YEAR VISION: Eliada extends its mission beyond our organizational boundaries**

Develop a training series for treatment, education and management services. Market to other non-profits and children's services organizations.

Develop career planning opportunities for current employees. Identify and assist employees who desire management career tracks in obtaining knowledge and skills to pursue opportunities both inside and outside the Eliada organization.

Work extensively with State and Federal Administrative Divisions to address quality and cost effective service

delivery. Introduce and advocate for a single chart of accounts, standardized allocation methodologies, and computerized variance reporting.

Develop linkages with Family and Juvenile Courts to provide preventative, treatment and educational services. Develop a Parent Coordinator Division to provide mediation services. Seek Foundation funding for judicial services.

Develop an employee incentive program to encourage community volunteerism and civic involvement. Rotary, Lions, Elks, Scouts, Youth Recreation leagues.

**20 YEAR VISION: Eliada sustains a culture that embodies our Core Values: Faith, Hope & Love, Excellence, Teamwork, & Integrity.**

Complete an employee handbook to include Eliada history, performance expectations, organizational structure and values, as well as operational guidelines. Develop hard copy as well as on-line version.

Produce an updated video to include information on each department of Eliada. Include performance expectations, attire, boundaries, interpersonal relationships and linkage

between each department and Eliada as a whole.

Improve record retention system. Identify optimal placement of record archives on campus. Purge all non-required records. Develop effective and efficient document retrieval system. Develop full electronic storage system.

Computer scenario modeling for Financial/Program options.

**20 YEAR VISION:** Eliada has highly skilled staff who find their work rewarding.

Expand training options for experienced treatment staff and foster parents.

Provide Qualified Professional training on family dynamics; group work with families and engaging resistant families in treatment.

Expand RISE program to include a residency program for professionals in their respective fields. Include accounting, human resources, and MIS. Goal of 1,000 applicants/year for RISE positions.

Develop departmental succession plan. Identify core competencies required and develop training resources to address those needs.

Develop virtual human resources specialists - utilizing artificial intelligence, internet and "bot", the virtual HR specialists could collect initial information for applicants for employment, inform supervisors of training requirements for their subordinates, and provide basic policy and practice training.

Achieve rating in the top 25% tier for wages and benefits in the market and service arena.

Develop an Enhanced Retirement Plan that would allow an employee in direct line services to retire with a secured standard of living.

**20 YEAR VISION:** Eliada is financially independent through endowments, benefactors, and public/private funds. Eliminate dependence on federal and state public funding.

Achieve annual revenue goal of 15 million by June.

2.5% profit margin for combined services. Annual operations profit of \$375,000.

Diversify funding streams- reduce medicaid funding percentage of total revenue from 83% to 60%.

Work with Foundation to conduct successful capital campaigns.

**20 YEAR VISION:** Eliada is nationally recognized for its services and organizational culture.

Collect data on performance indicators and post quarterly on the webpage. Utilize this data to direct programmatic and clinical decisions and initiatives.

Present outcome results and program evaluation model at a national conference. Initiate peer review of outcomes measurements and model with agencies, foundations and research entities throughout the United States.

Publish an article in a national publication on program evaluation model.

Change Eliada Homes name to simply ELIADA. Rebrand to honor the past, but accurately depict what Eliada is today and what it is striving to become in the future.

Become a national voice for the importance of Early Brain Development. Eliada would develop a campaign that would stress the importance of a stable, supportive environment during the first 5 years of life.

# ELIADA

Faith, Hope & Love. Excellence. Teamwork. Integrity.

2 Compton Drive  
Asheville, NC 28806  
www.eliada.org

828.254.5356 (p)  
828.259.5384 (f)  
info@eliada.org

# SUCCESS STORIES



*Our Success Stories series was created as a way to communicate with our friends and donors in an efficient, inexpensive format. Each month, we feature one of our programs and the inspiring story of a child whom the program has helped. To be added to the Success Stories email list, send your email address to [successstories@eliada.org](mailto:successstories@eliada.org).*

A few months ago, Matt was an angry, sullen 9th grade student struggling in public school. Although he had tremendous potential, Matt's lack of discipline and poor study skills kept him from realizing academic goals. He was unable to manage his time and focus his efforts effectively. Unable to keep up with his peers academically, Matt lashed out at his teachers and fellow students. Embarrassment over his failing grades manifested in serious behavioral issues; meanwhile, Matt fell further and further behind.

Finally, Matt was referred here, to Eliada Academy. Here, he has achieved the kind of success that eluded him in public school. Now, Matt has nothing to be embarrassed about; not only is he the Eliada Academy 'Science Student of the Month', he now believes in his own potential and is motivated to learn and acquire new skills. Matt's teachers report that he now takes initiative in class, and is among the first to volunteer answers or read aloud.

According to Matt, Eliada has helped him with his anger management and with reading comprehension skills. Although he had a difficult start, he now sees infinite possibilities in his future and continues to progress as a student and an individual.



Matt, February 2006

# S U C C E S S S T O R I E S



*Our Success Stories series was created as a way to communicate with our friends and donors in an efficient, inexpensive format. Each month, we feature one of our programs and the inspiring story of a child whom the program has helped. To be added to the Success Stories email list, just send your complete e-mail address to [successtories@eliada.org](mailto:successtories@eliada.org).*

Brandy was referred to Eliada Academy from the public school system almost one year ago. She had difficulty respecting teachers and other adults, often engaging in physical and verbal altercations with her peers. Unable to appropriately communicate her feelings, she often displayed angry outbursts both at school and home.

For the first several months, Brandy was less than receptive to feedback and rarely accepted any responsibility for her behavior.

There were many incidents where she walked out of the classroom or school building because she didn't like what feedback staff had given her. She often became overwhelmed with the environment and chose to isolate herself from her peers. During her monthly plan of care meetings, Brandy rarely participated and, if she did, would once again not accept feedback nor identify areas she needed to improve. Despite these challenges, there were signs of progress over the year that ensured that although she might not improve quickly, Brandy did have the necessary skills to succeed.

It was while attending day treatment during the summer that real change began to occur. Staff worked with Brandy extensively and noticed that gradually her level of self-confidence and the pride in which she took in her school work and personal appearance began to improve. She began to participate in her monthly plan of care meetings and has recently been able to recognize her own success, even identifying areas in which she has improved. Previously Brandy would walk away from a staff when being given feedback, currently she is receptive, maintains eye contact and accepts responsibility for her own actions and behavior. Brandy now stays in class, and is proud of the improvement in her grades. She points to her involvement with the TASC equestrian program as a highlight of her time at Eliada.

Brandy's relationship with her mother has also improved, and her mother notes a marked change at home with Brandy's overall maturity level. She is more responsible for herself by making sure she is prepared for school with a clean uniform and ensuring she is getting sufficient sleep. Eliada Academy staff is very proud of Brandy and the progress that she has made. Brandy will be returning to the public school system very soon and the staff feels confident that she will be successful there and in life beyond Eliada.



Brandy, September 2006

# Austin Reaches for the Stars



“Success is not measured by what you accomplish, but by the opposition you have encountered, and the courage with which you have maintained the struggle against overwhelming odds.”

-Orison Swett Marden

Austin came to Eliada Academy as a student whose life was on the verge of spinning out of control. He had a complete disregard and disrespect for authority and a crippling lack of motivation. These issues were complicated by attention problems and what was at times severe depression. After he was expelled from public school, those who cared for him felt that Eliada Academy was his best hope.

With the help of his teachers here at Eliada, Austin has learned how to interact politely with authority figures and his peers. He has gained patience, resiliency, and the ability to ask for help. He is no longer ashamed of his academic challenges, and no longer brings himself down with harsh self-criticisms or comparisons to others. He responds well to feedback and is an all-around likeable young man.

A significant part of Austin's turnaround has been his participation in the National Youth Project Using Minibikes (NYPUM), which is a Honda-sponsored program that rewards positive choices with the opportunity to ride a minibike. According to Kristy Eubanks, the NYPUM Director here at Eliada, "Austin had some real issues with following instructions and taking feedback from adults when he first started my program. This past year he has really improved! He has shown some great leadership and has been one of my junior leaders since last fall. He has become more responsible and I have had him come and help me with one of my younger classes. He likes to teach and does a

great job stepping up and doing so when asked. He is a joy to have in NYPUM and I hope he's a part of the program for years to come!"

Just a few weeks ago, Austin's success in NYPUM earned him a trip to the Berkshire Mountains for the 2009 National NYPUM Rodeo, where Austin was one of a handful of Eliada students who got the opportunity to compete in a weekend of activities similar to the Olympics of the NYPUM program. He met other NYPUM students from across the Southeast and represented Eliada extremely well. Austin set a wonderful example of sportsmanship, cheering for other teams and acting as an overall positive leader.

Austin has also taken a leadership role in "Amazement", a student-run Junior Achievement Company at Eliada. Through "Amazement", participating students will sell glow lights and candy apples during Eliada's "Castle in the Corn Maze", which will operate through Halloween. Through this experience, the students are gaining hands-on experience in marketing, production, public relations, human resources, and other aspects of creating and running a company. Austin was elected the Vice-President of Human Resources, and has flourished in that role.

All of us at Eliada are so proud of Austin's achievements. Congratulations, Austin!

# Tyler Learns Skills to Succeed



"If one advances confidently in the direction of his dreams, and endeavors to live the life which he has imagined, he will meet with success unexpected in common hours."

-Henry David Thoreau

Tyler came to Eliada Academy Day Treatment with behavioral problems and a history of threatening other students. He suffered from extreme anxiety. If something unexpected came up in his daily routine, Tyler became anxious and would worry excessively over the situation. His family recognized that public school wasn't the best environment for Tyler. Through research, they found Eliada.

At first, Tyler was a little skeptical about what Eliada could do to help him. However, he knew he had to do something different. He wanted to succeed in school and, with the support of his family, agreed to give Eliada a chance. According to one of his teachers, "Tyler came to us with very little confidence. He was constantly anxious, which would cause him to become frustrated and angry in class. After he calmed down he would feel remorseful. It was a very negative cycle."

A turning point came for Tyler when he became part of the TASC program. He was initially frightened of horses, so much so that he felt he would never want to ride one. Gradually, he became more comfortable with the animals and gained confidence around them. He has come to

love horses so much that now he even has his own at home!

Over time, Tyler learned coping skills to help him deal with anxiety and stress. Now, he is able to calm himself down when his emotions escalate, and is able to complete assignments and follow instructions. Tyler now feels that Eliada is the "best thing that ever happened to him." He is especially grateful for the support of his teachers; he gives special credit to Pete Thomas, Tim Fagan, and Carrie Melear.

Today, Tyler is gradually transitioning back to public school. Currently, he is part-time at his old school and part-time at Eliada. Although he feels some trepidation about returning to school full time, he believes he has the skills to succeed. He feels very positive about his future. To quote Tyler, "All the people here have been so great! They try to help us become better people. They have gone out of their way to help me. I would like to thank all of the staff at Eliada."

Congratulations, Tyler. We're all very proud of your success!



# SUCCESS STORIES



Our Success Stories series was created as a way to communicate with our friends and donors in an efficient, inexpensive format. Each month, we feature one of our programs and the inspiring story of a child whom the program has helped. To be added to the Success Stories email list, just send your complete e-mail address to [successstories@eliada.org](mailto:successstories@eliada.org).

Randy and Carrie Fugate adopted Chioke at the age of 15 months. Even though he was too young to remember the environment he was adopted from, it was clear that the chaos and uncertainty of his prior living situation had made an impact. Fortunately for Chioke, he had the support of a loving adoptive family who would do anything to see him be successful.

From the start, Randy and Carrie watched Chioke bounce between positive and negative extremes. When he entered into public school, he began to struggle. They took him to several specialists and received multiple diagnoses, which was confusing and left them wondering which of the expert recommendations to focus on. Meanwhile, he continued to get into trouble at school. He was suspended and sent home almost daily. Randy and Carrie felt Chioke's issues at school came from his disabilities, but they didn't know how to help him.

In September of 2009, Chioke came to Eliada's Day Treatment program. Initially, it was a rollercoaster ride for both Chioke and Eliada's staff. At Eliada, Chioke exhibited many of the same problems that he experienced in public school. He was physically aggressive, confrontational, and unable to accept any feedback. He had poor peer relationships and was often removed from class for threatening other students. It was many months before

Chioke was able to remain in class for a full day.

Consistency and structure is one of the hallmarks of the Eliada model, and Chioke's teachers stood their ground and didn't give up on him. Over time, Chioke revealed himself to be a very unique, smart, and entertaining young man. As his teachers got to know him, they learned that one of his biggest hobbies is collecting antiques. He is a collector of old coins, phonographs, records, and almost anything that is considered antique. His teachers encouraged him to bring in his collectibles to "show and tell." Chioke enjoyed telling his peers the history of each antique, which helped to grow his relationships with other students.

While he once avoided all books with text, Chioke is now able to read books at his grade level. His ability to focus on and complete tasks has improved noticeably. Receiving consequences, once a guaranteed trigger for Chioke that would cause him to scream in frustration, is now met with a simple "ok." While Chioke still has some progress to make before he is able to return to public school, his accomplishments to this point have been remarkable.

According to Chioke's mother, his biggest advocate, "Eliada created a safe and structured environment for Chioke to grow in. It's been a saving grace... We are very proud of our son and all the progress that he has made." Congratulations, Chioke!



Chioke, September 2010

## AJ: RESIDENTIAL CARE & DAY TREATMENT



A.J. came to Eliada as a young man without a permanent home. A native of Baltimore, he was moved between various relatives before eventually living with his grandmother in Charlotte. There, he got into serious trouble.

"My friends were not a good influence, and I got involved with a car theft," he says of the circumstances leading to his arrival. Afraid and facing jail time, he was fortunate that his probation officer and case manager felt he could benefit from a different environment.

Together, they decided that Eliada was an alternative that could work for the troubled young man.

Angela Moser, one of A.J.'s teachers, remembers his first days as difficult ones. "He originally began in my class with a low self-esteem and the thought that he would not be able to be successful," she recounts. He had conflicts with peers, easily gave up on his assignments, did not complete homework, and argued with adults.

Now, Ms. Moser and others describe a very different student, one who accepts feedback and works hard to improve himself. "A.J. now gets along with his peers and has become an amazing role model. He provides them with real-world examples of how education can benefit their lives. He has the highest math percentage among the 8th grade students in the school, and is very proud about that. He is an absolute success story!" she says.

*"My picture was in the paper. It was the first time I was ever in the newspaper for something positive."*

Since his placement at Eliada, A.J. feels he has learned a greater respect for people, as well as to think on his own. His goal is to be more independent and take caution with peer groups that could influence him in a negative manner. "I do not want to go back to where I was, always getting in trouble", he says. "Here, I got to do things like be part of the winter formal and be on the basketball team. My picture was in the paper. It was the first time I was ever in the newspaper for something positive."

A.J. will leave Eliada this week and move to Winston Salem to live with his Aunt and cousins. Although he will miss the staff, his friends, basketball, and the NYPUM minibike program, he is looking forward to this transition. He rarely sees his sister and 8 brothers, and hopes his Aunt's home will be more like a family than other places he's lived.

A.J. has learned from past mistakes and loves the positive attention he now enjoys. He has set high goals for himself, including attending college to study Psychology. Whatever he chooses to do, all of us at Eliada are confident that this young man has a bright future. Congratulations, A.J.!

## Appendix: Goals Timeline

### Admission

(1st 30 days)

- BASI Standardized Assessment
- Review prior academic records
- SEP developed
- Behavior survey (PARC)

### Education

(periodic reviews throughout)

- SEP reviewed (every 3 wks)
- Weekly clinical team reviews (treatment and academics)
- Monthly progress reports to be reviewed at CFT meetings
- Report cards (every 9 wks)
- BASI administered at treatment mid-term (approx. 3 mo)

### Transition (last 30 days)

- Interventions and strategies reviewed and edited
- Transition Plan drafted to outline effective treatment/academic strategies for student
- To be completed within last 30 days

## **PURPOSES OF PROPOSED CHARTER SCHOOL**

### **Eliada Academy will:**

**\*Improve student learning** through the implementation of innovative, research-based educational practices designed to meet students' unique, individual learning styles. Pedagogy will focus on the utilization of discovery learning, inquiry-based learning and cooperative learning practices and emphasize the development of appropriate student conduct, positive peer relations, personal organization and formative self-assessment. Academic instruction will focus on enriching students' understanding of integrated academic content, where students are exposed to new curriculum material while reviewing and mastering core concepts to establish connections between fundamental skills and higher-order thinking, deep knowledge and comprehensive understanding.

**\*Increase learning opportunities for students, especially those identified as academically at-risk (or academically gifted,)** through the use of an educational model that integrates behavior modification treatment with academic learning. Class sizes are small with ratios of one staff to three students in the residential program and one staff to four students in the day treatment program. Teachers work in partnership with a treatment specialist to implement a therapeutic model of behavior modification. Therapeutic models allow students the opportunity to perform and learn in a supportive environment that is structured to facilitate significant improvement in behaviors and academic achievement. The models used at Eliada Academy (both the day treatment and residential classrooms) provide a learning environment for this target population of children and adolescents with mental health diagnoses to be successful learners of academic content and to replace ineffective and inappropriate behaviors and habits with those that demonstrate success in school and the community.

**\*Encourage the use of varied, differentiated and innovative teaching methods and insure compliance and efficacy** with a regular regime of supervision, observation and evaluative dialog with the director. Educators will focus on continuous improvement measured by periodic evaluations that identify areas for improvement, develop strategies for improving teaching and learning and set goals for continued development of instructional skills.

**\*Create new professional opportunities for teachers** by engaging teachers in an ongoing process of evaluation and improvement of the educational model. Educators will participate in continuing and sustained professional development to sharpen skill in the content areas, instruction and assessment and teaching at-risk children and adolescents. Educators will research, experiment with and reflect on research-based educational methods and concepts.

**\*Expand educational opportunities to the local community** by providing students with acute mental health issues and who have distinct special education needs, an opportunity to engage in a therapeutic and supportive learning environment. Students within our target population, whose success in public schools has been diminished by lack of access to appropriate support and accommodation, will have access and choice of opportunities for educational success through the treatment-enriched curriculum provided at Eliada Academy.

**\*Hold all stakeholders accountable for meeting measurable, performance-based student outcomes,** using standardized evaluation tools for student and teacher performance. Goals of

continual, formative growth and development for students and educators will drive the program. Student learning will be evaluated by local and state measures. In the event that teachers do not meet the expected performance standards and show a deficiency in one or more areas, a mentor teacher will be assigned to assist them in improving their skill set, additional professional development and coaching will be scheduled and more frequent observations will monitor progress toward improvement. Administrative evaluation will include an annual financial audit and the Eliada Academy Board will receive financial reports on a monthly basis.



**A BRIEF OVERVIEW:  
PROGRAM EVALUATION REPORT FY 2011**

**ELIADA HOMES, INC.**

# Demographics

## Gender

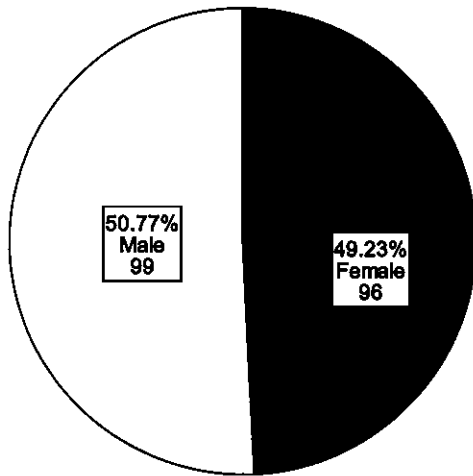

## Race

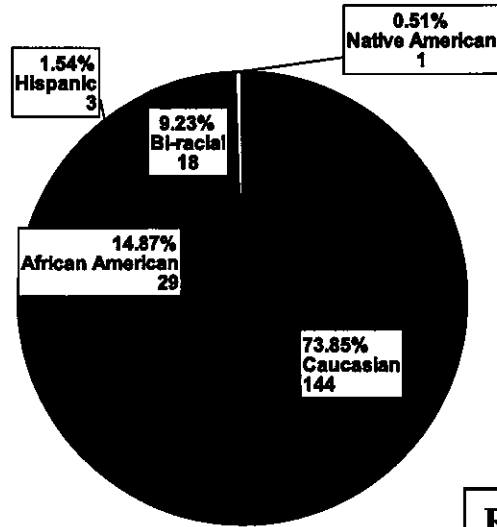

“Eliada’s awesome. It’s helped me a lot!”

~ Reuter student at discharge

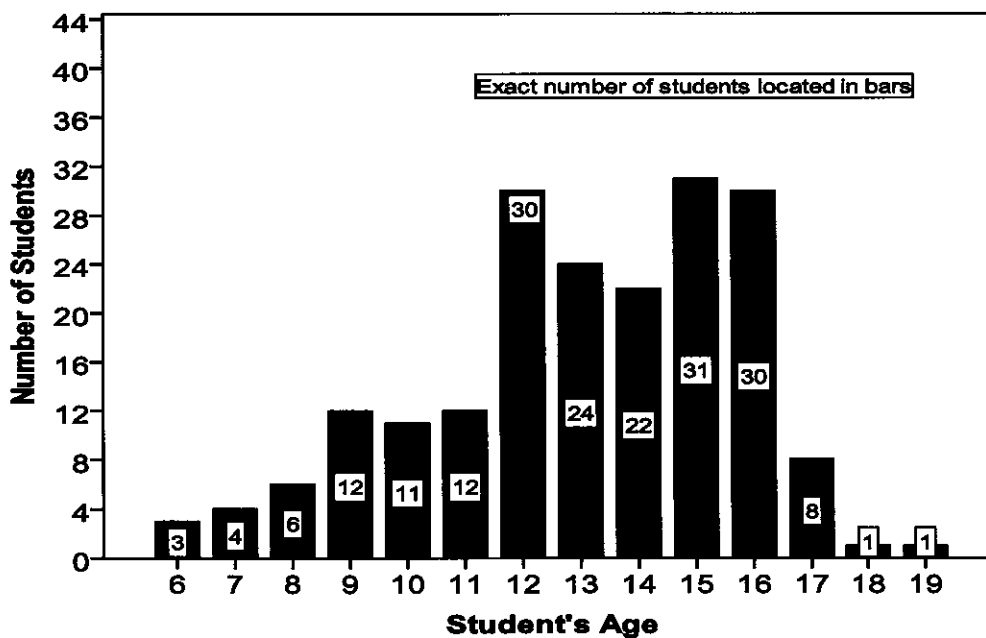

### Facts

195 Students served

#### *Gender*

49% Female

51% Male

#### *Race*

- Majority Caucasian
- 4% increase in number of African American Students served

- Racial Statistics reflect Buncombe Co. Demographics

#### *Age*

Average Age: 13

Mode: 15

Range: 6-19

“I’ve learned that all behaviors are pain based.”

~ Rise Staff

**Primary Diagnosis Facts**

Total Number of Primary Diagnoses

-83% of students have more than 1 primary diagnosis

Top Diagnoses

- Oppositional Defiant Disorder
- Post Traumatic Stress Disorder
- Mood Disorder

Primary Diagnosis

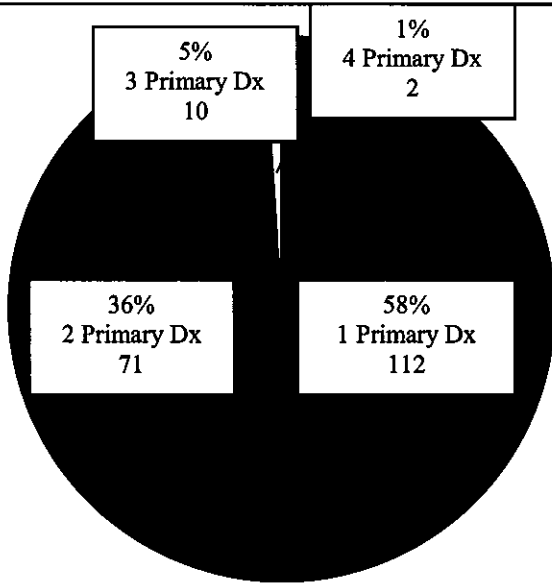
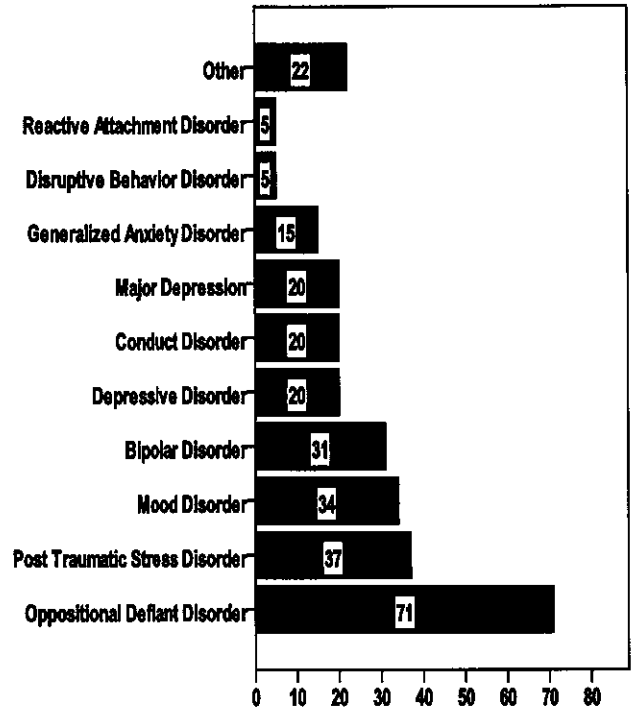

“They come with so many previous placements that they seem molded to being institutionalized rather than wanting to fix themselves.”

~ RC Staff

Total Number of Students Who Have Had at Least 1 Previous Placements/Services In Each Category

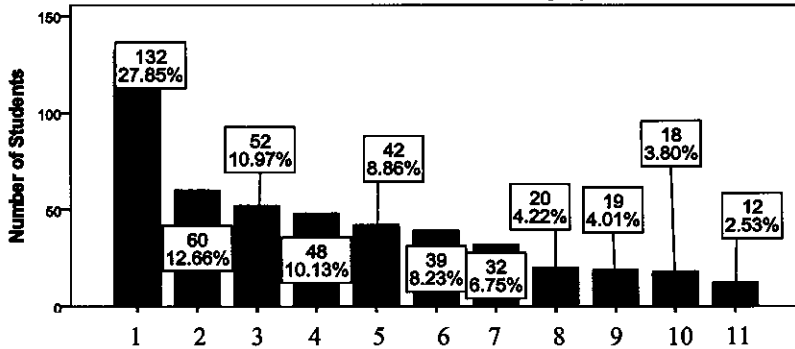

- |   |                           |
|---|---------------------------|
| 1) Psychiatric Hospitalization                | 7) Day Treatment          |
| 2) Therapeutic Foster Care                    | 8) Level II – Residential |
| 3) Level III                                  | 9) Respite                |
| 4) Psychiatric Residential Treatment Facility | 10) Detention             |
| 5) Intensive In-Home                          | 11) Other                 |
| 6) Foster Care                                |                           |

**Facts**

- Average: 4 previous placements/services
- 95% have more than 1 previous placement
- Psychiatric Hospitalization most prevalent previous placement/service

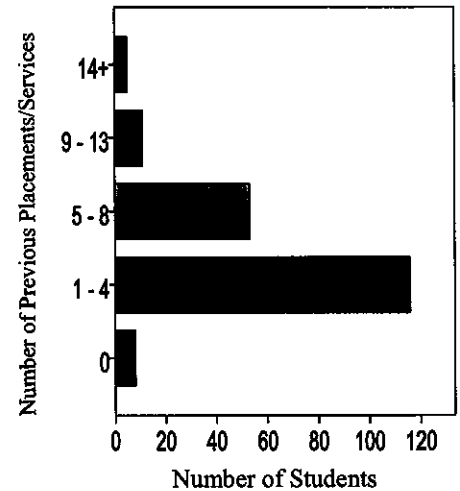



What does this move (stepping down from PRTF to TFC) mean to you?

“To get a family, a forever family, so that I can try to get further in life and go in the right direction like college and things like that.”

~ Student step-down interview

## Qualify For Title 1

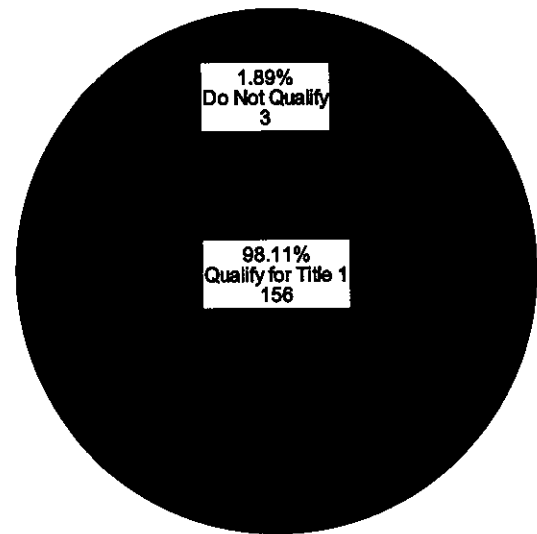

## Special Education

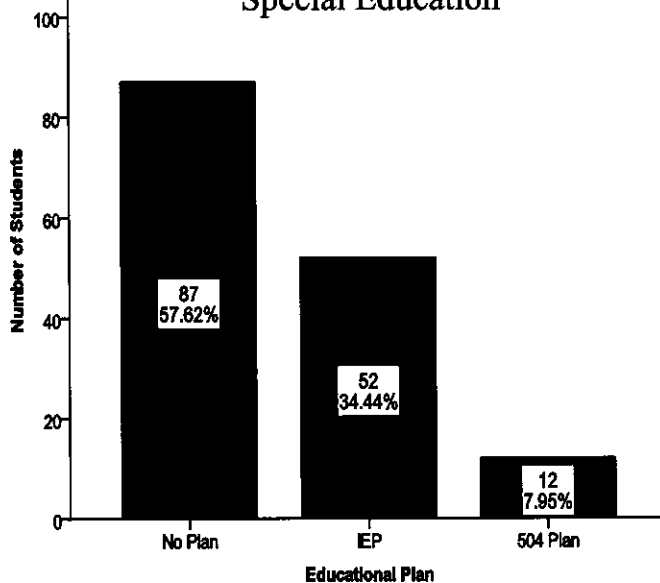

## Facts

### *Title 1*

- Title 1 is the largest federally funded education program
- Provides supplemental funds to schools with high concentrations of poverty
- 98% of Eliada students qualify

### *504 Plan*

- Students who don't qualify for Title 1, but still need accommodations

### *Special Education*

- Federal government requires all students who qualify for special education to have an Individualized Education Plan (IEP)
- 34% of students have an IEP
- The area of eligibility for special education is Behaviorally-Emotionally Disabled for 52% of students

“I am a custodian and a guardian of these kid's academic skills. My job is to keep them sharp, keep them acclimated to the classroom, to not let their skills erode any further than they already have.”

~ PRTF Teacher

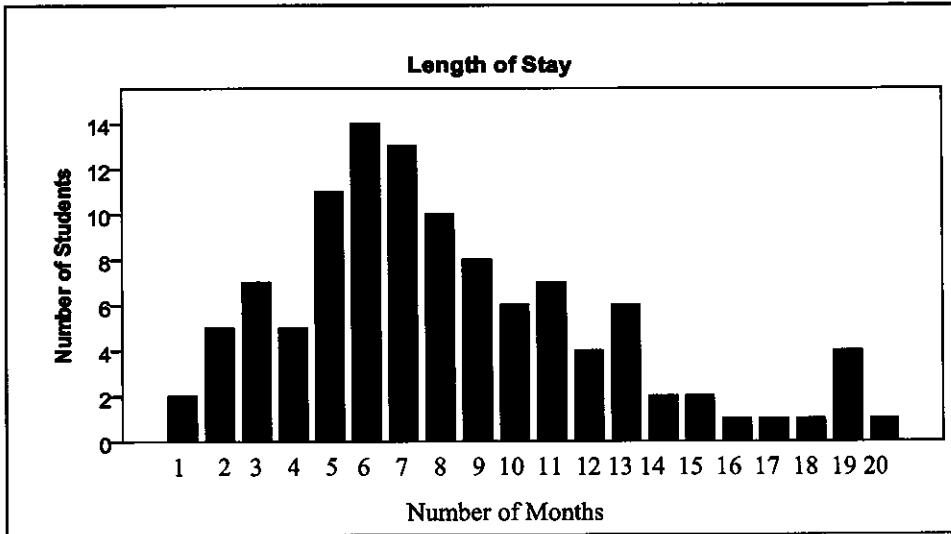

### Facts

- 112 students completed treatment
- Average length of stay: 9 months
- Removing outliers the average length of stay is approximately 6 months
- Range: 1 month – 4 years, 3 months
- TFC students have longest length of stay

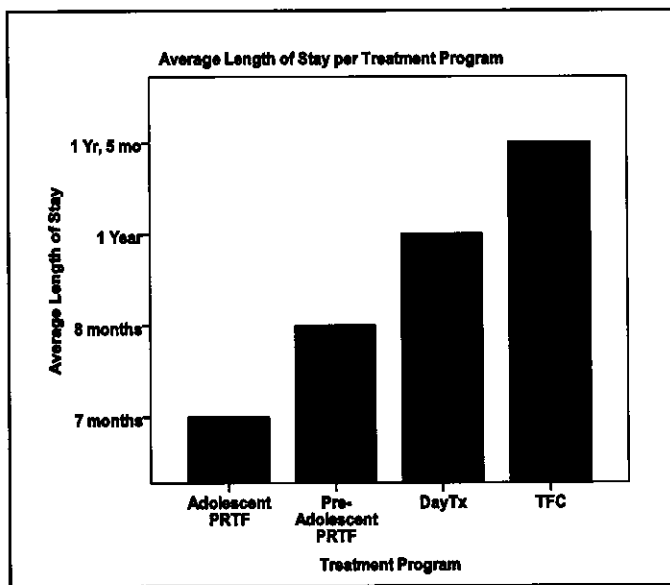

“I wish that I had done what Eliada suggested, but I felt like he should be home with me. If I could do it over, he’d still be at Eliada today.”

~ Longitudinal Survey: Parent

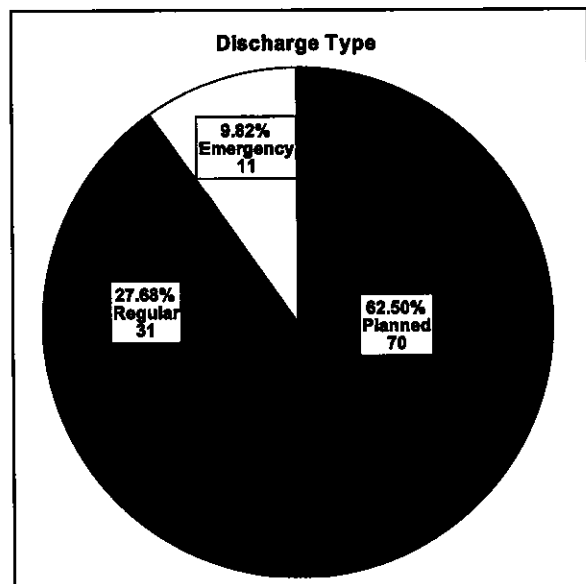

### Discharge Types:

**Planned:** Student completed program and followed original plan developed at admission

**Regular:** Student completed program; however, original plan was modified according to student needs

**Emergency:** Child left program suddenly without placement preparation (often the result of emergency psychiatric hospitalization)

### Facts

- 112 students completed treatment.
- 90% had either a planned or regular discharge
- 10% had an emergency discharge; this is a 20% decrease from last year in emergency discharges
- 46% of students who had planned discharges stepped down to the home of their parents
- 91% of students with a regular discharge remained in the Eliada continuum

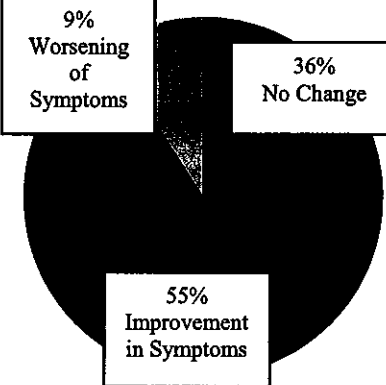
<p><b>Communication Scale</b></p>  <p>9% Worsening of Symptoms</p> <p>36% No Change</p> <p>55% Improvement in Symptoms</p>	<p><b>Fact</b></p> <p>-Parent Adolescent Relationship Questionnaire measures family relational skills</p> <p>-55% of students showed significant improvement in communication abilities</p>	<p>“I don’t get mad at my mom like I used to. We get along better. I also get along better with my sisters.”</p> <p>~ Longitudinal Survey: Student</p>
---	---	--

## Longitudinal Survey Data

<p style="text-align: center;"><b>Facts</b></p> <ul style="list-style-type: none"> <li>- 48 parents and students participated</li> <li>- 40% of participants surveyed 6 months after discharge</li> <li>- Student participants had been discharged from Eliada from 3 months to 3 years</li> </ul>
--

“Overall the program was really helpful. They had plenty of activities like the bike program (NYPUM), staff interaction, railroad project, sports, and going on trips.”

~Longitudinal Survey: Mom

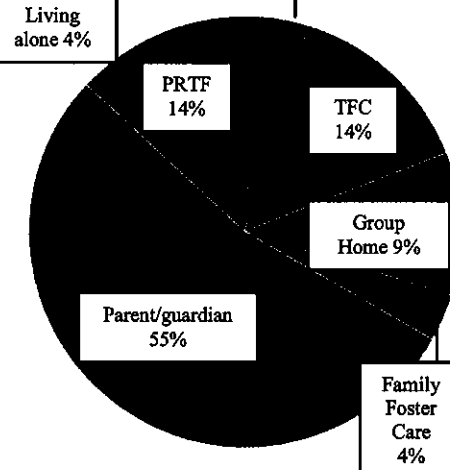
<p><b>Current Living Placement</b></p>  <p>Living alone 4%</p> <p>PRTF 14%</p> <p>TFC 14%</p> <p>Group Home 9%</p> <p>Parent/guardian 55%</p> <p>Family Foster Care 4%</p>	<p><b>Discharge Placement</b></p> <ul style="list-style-type: none"> <li>- 55% live with parent/guardian</li> <li>- 61% remained in placement that Eliada discharged them to</li> <li>- 48% had temporary out of home placements</li> <li>- 31% had only 1 out of home placement</li> <li>- Psychiatric hospitalization is most common temporary out of home placement</li> <li>- Out of home temporary placements last between a couple weeks – 4 months</li> </ul>
---	--

<p><b>Economic Assistance</b></p> <ul style="list-style-type: none"> <li>- 77% claim to receive government assistance (Food Stamps, SSI, etc.)</li> <li>- Average annual household income was lower than \$20,000</li> <li>- 25% had annual household income of \$14,999 or less</li> </ul>	<p><b>Extra Facts</b></p> <ul style="list-style-type: none"> <li>- Zero participants claim to have been the victim of a violent crime</li> <li>- None of the participants claim to have children</li> <li>-13% of students are employed</li> <li>- Work on average 15 hours a week</li> <li>- Held jobs between 3 months – 1 year</li> </ul>
---	--

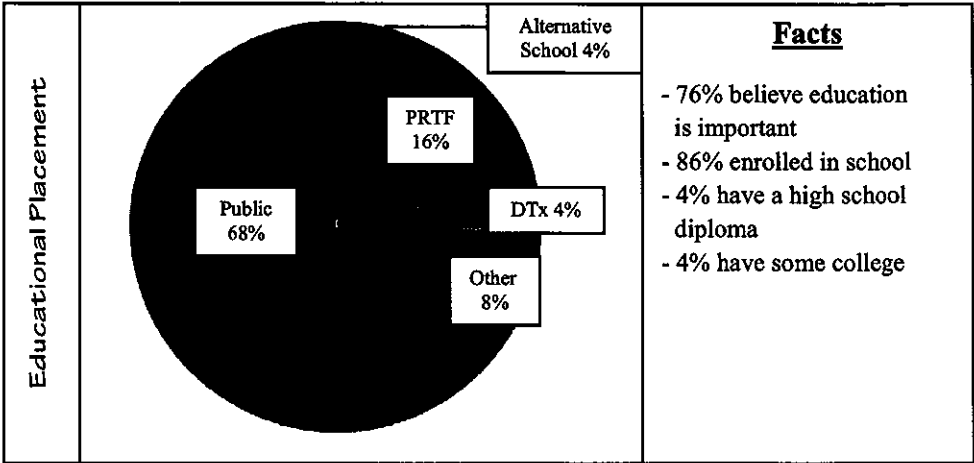

**“I do whatever the boss tells me to. It’s my first job and I love working!”**

~ Longitudinal Survey: Student

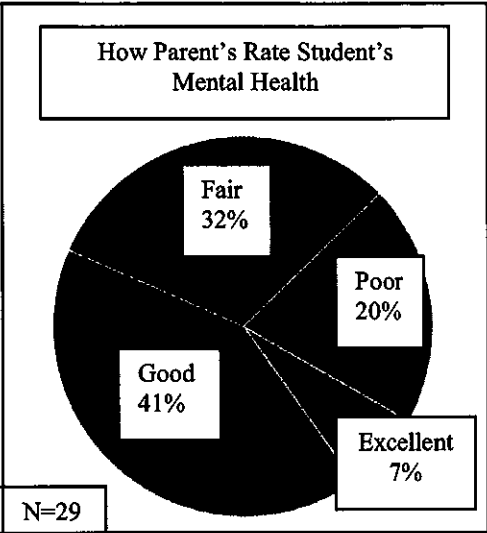
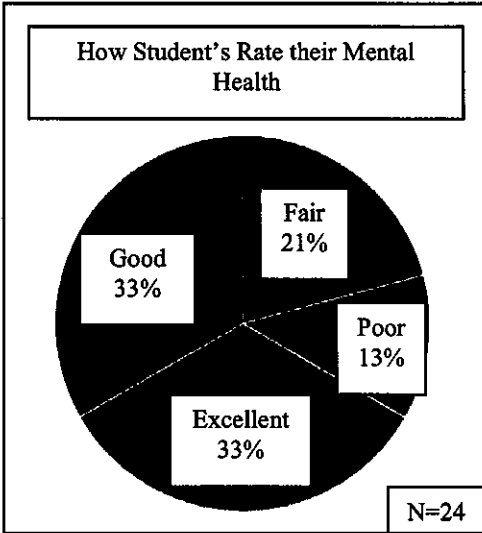

**Facts**

- Parents and students assess student’s mental health differently
- 33% of students rate mental health as excellent
- 7% of parents rate student’s mental health as excellent
- 73% of students are seeing a therapist/psychiatrist
- 73% of students are taking mental health prescription medication

**Pro-Social Activities/Behaviors**

1: Often  
2: Sometimes  
3: Rarely  
4: Never

- 73% of students participate in creative outlets
- Over ½ of students say that they never think about hurting themselves
- 74% of students say that they rarely or never think about hurting others
- 64% of students say that they don’t use drugs recreationally

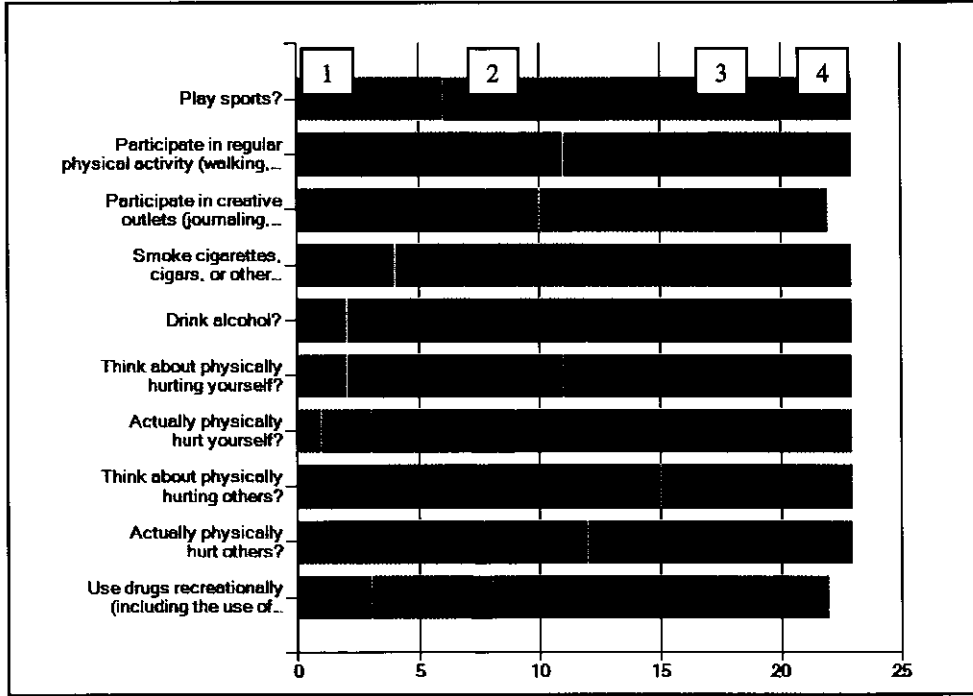

# A Longitudinal Follow-Up

## What did Eliada do that was helpful?

Students:

“Eliada changed me. I didn’t want to leave!”

“When I was going through hard times they were there for me. They supported me and gave me advice about things that would help me in the future. They talked to me a lot about coping skills.”

“Eliada taught me that not everyone/thing around you is terrible.”

“Eliada found me a home that loves me.”

~Student

Parents:

“Everything!”

“The referral to the new placement at his discharge was perfect.”

“Eliada staff and therapist met my child where he was at – that made a really big difference. They didn’t push him; they let him progress at his own pace.”

## What skills did you learn at Eliada that you are still using today?

Students:

“Well, since I started as a camp counselor assistant, I see that it is real hard to be responsible and always doing the right thing.”

“I have learned to be patient and I have learned to concentrate on my school work.”

“I have learned to go by the rules. When I go by the rules I get stuff that I like.”

“I still ‘take space’.”

“I have learned to express my feelings better. To not let things bother me so much. I have learned to go with the flow.”

“Impulse control – I think before I act now.”

Parents:

“He is doing really well. He is taking responsibility for his actions.”

“Coping skills - that is one of the things they did that was good. He’s not using it as much as he used to.”

“Coping skills and learning to have friends.”

“He doesn’t hurt others anymore.”

“She recognizes when she’s starting down the depression route and will ask for help.”

“Behavior modification, using love and logic method.”

“I’ve learned to give space, but also appropriate consequences.”

~ Parent

“My son continues to talk about his time at Eliada. He really enjoyed cooking in the cottage, the trips that Eliada took him on, and the running program. It was all really important. It wasn’t one thing in particular – it was the whole thing.”

~ Longitudinal Survey: Parent

**2011-2012 Framework for Outcomes Measurement: Eliada Academy Charter School**

<b>Outcome</b>	<b>Indicators</b>	<b>Data Source</b>	<b>Data Collection Method</b>
Improved Academic Performance	55% of students will increase a grade level in reading. 45% of students will increase a grade level in math.	Students	School-administered Benchmark Test/BASI at admission and again one month prior to discharge; Review of teacher admission and discharge summaries for individual students.
Decreased frequency/intensity of crisis episodes.	Students will show an increased ability to manage behaviors as measured by a 50% decrease in restraints and out of control behavior incidents.	Program Staff	Incident reports will be used to track incidents and behavioral incidents.
Integration into an appropriate educational and living setting.	70% of students will be placed in an appropriate living and educational setting.	Program Staff, Guardian	Student's educational and living setting will be tracked through pre- and post-measures using ROLES Assessment and ROLES Education.
Improved social, emotional, and behavioral functioning in home and educational setting.	50% of students will show improved social, emotional, and behavioral functioning as measured by the CAB	Program Staff, Guardian	Improvement in social functioning will be measured in a pre- and post-test using the CAB.
Improved communication and relational skills within family.	45% of students will show improved communication and social skills as evidenced by the PARQ	Students, Parent/Guardian	Increased use of communication and social skills will be measured by pre- and post-testing using the PARQ assessment tool.

# A Model of Learning Objectives

based on

*A Taxonomy for Learning, Teaching, and Assessing:*

*A Revision of Bloom's Taxonomy of Educational Objectives*

Among other modifications, Anderson and Krathwohl's (2001) revision of the original Bloom's taxonomy (Bloom & Krathwohl, 1956) redefines the cognitive domain as the intersection of the Cognitive Process Dimension and the Knowledge Dimension. This document offers a three-dimensional representation of the revised taxonomy of the cognitive domain.

Although the Cognitive Process and Knowledge dimensions are represented as hierarchical steps, the distinctions between categories are not always clear-cut. For example, all procedural knowledge is not necessarily more abstract than all conceptual knowledge; and an objective that involves analyzing or evaluating may require thinking skills that are no less complex than one that involves creating. It is generally understood, nonetheless, that lower order thinking skills are subsumed by, and provide the foundation for higher order thinking skills.

**The Knowledge Dimension** classifies four types of knowledge that learners may be expected to acquire or construct—ranging from concrete to abstract (Table 1).

Table 1. The Knowledge Dimension – major types and subtypes

concrete knowledge		abstract knowledge	
factual	conceptual	procedural	metacognitive
knowledge of terminology knowledge of specific details and elements	knowledge of classifications and categories knowledge of principles and generalizations knowledge of theories, models, and structures	knowledge of subject-specific skills and algorithms knowledge of subject-specific techniques and methods knowledge of criteria for determining when to use appropriate procedures	Strategic knowledge knowledge of abilities, including problem-solving and conditional abilities Self-knowledge

(Table 1 adapted from Anderson and Krathwohl, 2001, p. 46.)

\*Metacognitive knowledge is a special case. In this model, "metacognitive knowledge is knowledge of [one's own] cognition and about oneself in relation to various subject matters ..." (Anderson and Krathwohl, 2001, p. 44).

This taxonomy provides a framework for determining and clarifying learning **objectives**. Learning **activities** often involve both lower order and higher order thinking skills as well as a mix of concrete and abstract knowledge.

**The Cognitive Process Dimension** represents a continuum of increasing cognitive complexity—from lower order thinking skills to higher order thinking skills. Anderson and Krathwohl (2001) identify nineteen specific cognitive processes that further clarify the scope of the six categories (Table 2).

Table 2. The Cognitive Processes dimension — categories & cognitive processes and alternative names

lower order thinking skills		higher order thinking skills			
remember	understand	apply	analyze		
recognizing <ul style="list-style-type: none"> <li>identifying</li> </ul> recalling <ul style="list-style-type: none"> <li>retrieving</li> </ul>	interpreting <ul style="list-style-type: none"> <li>clarifying</li> <li>paraphrasing</li> <li>representing</li> <li>translating</li> </ul> exemplifying <ul style="list-style-type: none"> <li>illustrating</li> <li>instantiating</li> </ul> classifying <ul style="list-style-type: none"> <li>categorizing</li> <li>subsuming</li> </ul> summarizing <ul style="list-style-type: none"> <li>abstracting</li> <li>generalizing</li> </ul> inferring <ul style="list-style-type: none"> <li>concluding</li> <li>extrapolating</li> <li>interpolating</li> <li>predicting</li> </ul> comparing <ul style="list-style-type: none"> <li>contrasting</li> <li>mapping</li> <li>matching</li> </ul> explaining <ul style="list-style-type: none"> <li>constructing models</li> </ul>	executing <ul style="list-style-type: none"> <li>carrying out</li> </ul> implementing <ul style="list-style-type: none"> <li>using</li> </ul>	differentiating <ul style="list-style-type: none"> <li>discriminating</li> <li>distinguishing</li> <li>focusing</li> <li>selecting</li> </ul> organizing <ul style="list-style-type: none"> <li>finding coherence</li> <li>integrating</li> <li>outlining</li> <li>parsing</li> <li>structuring</li> </ul> attributing <ul style="list-style-type: none"> <li>deconstructing</li> </ul>	checking <ul style="list-style-type: none"> <li>coordinating</li> <li>detecting</li> <li>monitoring</li> <li>testing</li> </ul> critiquing <ul style="list-style-type: none"> <li>judging</li> </ul>	generating <ul style="list-style-type: none"> <li>hypothesizing</li> </ul> planning <ul style="list-style-type: none"> <li>designing</li> </ul> producing <ul style="list-style-type: none"> <li>constructing</li> </ul>

(Table 2 adapted from Anderson and Krathwohl, 2001, pp. 67–68.)



A statement of a **learning objective** contains a **verb** (an action) and an **object** (usually a noun).

- The **verb** generally refers to [actions associated with] the intended cognitive process.
- The **object** generally describes the **knowledge** students are expected to acquire or construct. (Anderson and Krathwohl, 2001, pp. 4-5)

In this model, each of the colored blocks shows an example of a learning objective that generally corresponds with each of the various combinations of the cognitive process and knowledge dimensions.

**Remember:** these are **learning objectives**—not learning activities. It may be useful to think of preceding each objective with something like: “Students will be able to . . .”

\*Anderson, L.W. (Ed.), Krathwohl, D.R. (Ed.), Airasian, P.W., Cruikshank, K.A., Mayer, R.E., Pintrich, P.R., Raths, J., & Wittrock, M.C. (2001). *A taxonomy for learning, teaching, and assessing: A revision of Bloom's Taxonomy of Educational Objectives* (Complete edition). New York: Longman.

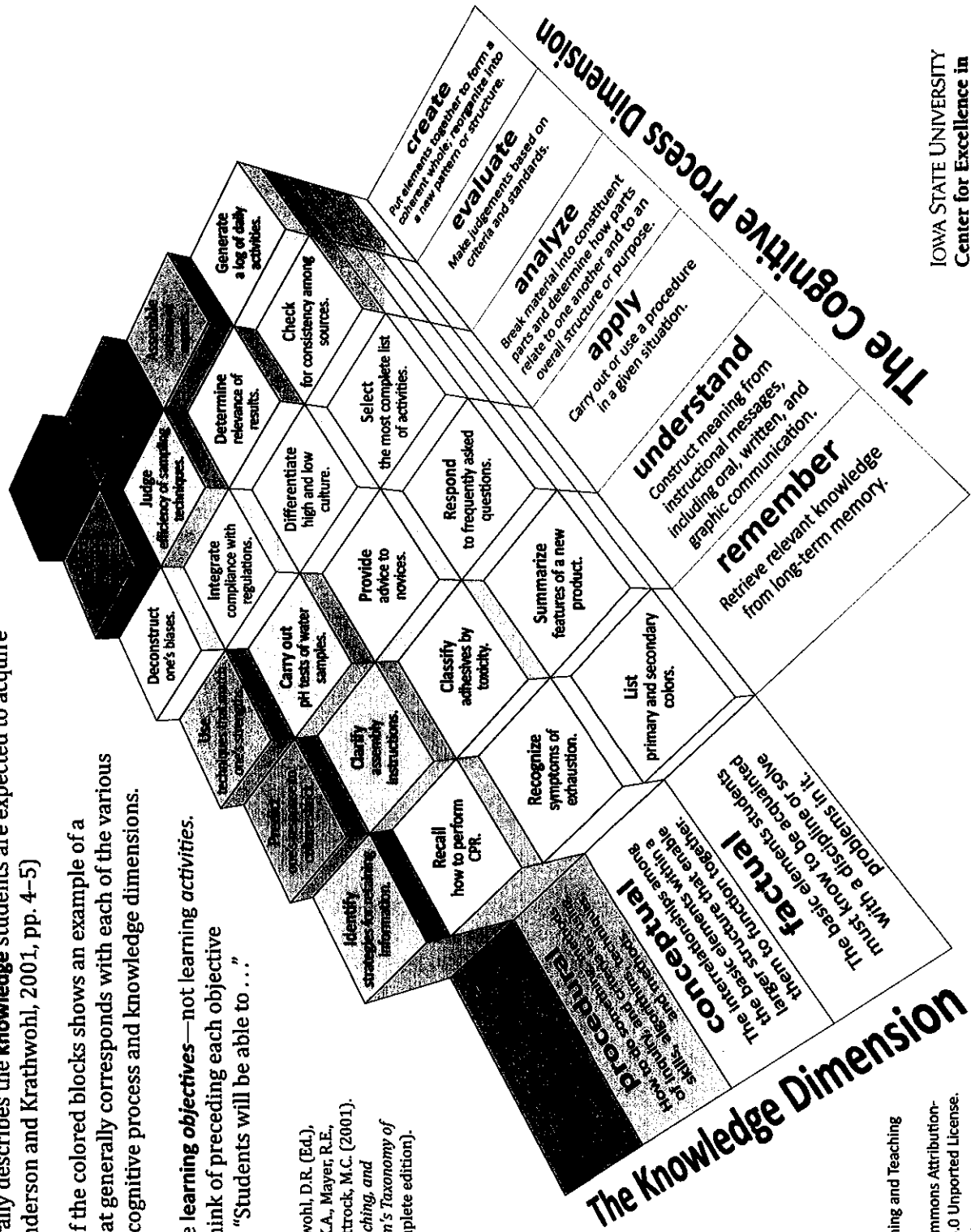

Model created by: Rex Heer  
 Iowa State University  
 Center for Excellence in Learning and Teaching  
 Updated January, 2012  
 Licensed under a Creative Commons Attribution-NonCommercial-ShareAlike 3.0 Unported License.  
 For additional resources, see:  
[www.celt.iastate.edu/teaching/RevisedBlooms1.html](http://www.celt.iastate.edu/teaching/RevisedBlooms1.html)

## Bloom's Taxonomy

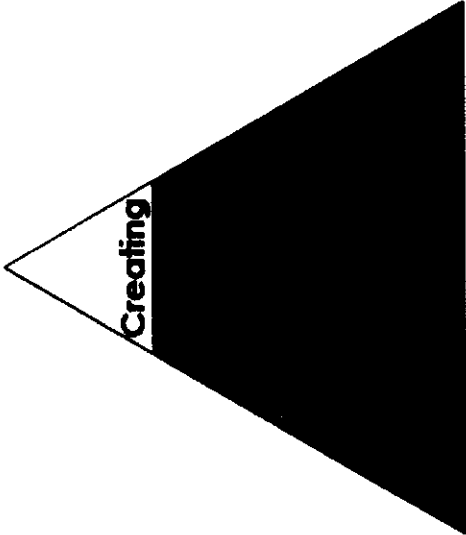
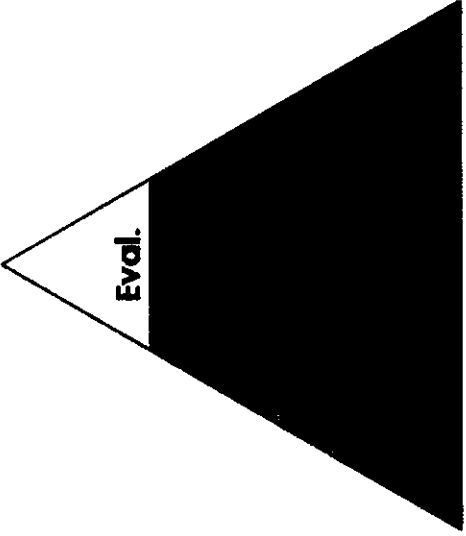
 <p><b>Creating</b></p>	 <p><b>Eval.</b></p>
<p><b>New Version</b></p>	<p><b>Old Version</b></p>
<p><b>Remembering:</b> can the student recall or remember the information?</p>	<p>define, duplicate, list, memorize, recall, repeat, reproduce state</p>
<p><b>Understanding:</b> can the student explain ideas or concepts?</p>	<p>classify, describe, discuss, explain, identify, locate, recognize, report, select, translate, paraphrase</p>
<p><b>Applying:</b> can the student use the information in a new way?</p>	<p>choose, demonstrate, dramatize, employ, illustrate, interpret, operate, schedule, solve, use, write.</p>
<p><b>Analyzing:</b> can the student distinguish between the different parts?</p>	<p>appraise, compare, contrast, criticize, differentiate, discriminate, distinguish, examine, experiment, question, test.</p>
<p><b>Evaluating:</b> can the student justify a stand or decision?</p>	<p>appraise, argue, defend, judge, select, support, value, evaluate</p>
<p><b>Creating:</b> can the student create new product or point of view?</p>	<p>assemble, construct, create, design, develop, formulate, write.</p>
<p><i>Note that the top two levels are essentially exchanged from the traditional to the new version.</i></p>	

**Richard C. Overbaugh**  
**Lynn Schultz**  
**Old Dominion University**

## **Appendix: Curriculum Design Outline for 1-5 Language Arts and Social Studies—Discovering the Humanities**

- An integrated approach to learning English/Language Arts (*How We Communicate*), Social Studies (*How We Live*), and Fine Arts (*How We Express*) with a humanistic focus
- Cultural thematic units centered around history, culture, music and art will be used to drive learning of reading and writing fundamentals
- Therapeutic synthesis focused on having students understand their own cultural perspective through the explorations of local and global civilizations, both past and present

*This integrated approach to humanities, through language and history, is intended to create students that are sensitive to cultures, how they relate, and can effectively communicate how individual and global identities are shaped by culture.*

### **How We Communicate—English/Language Arts Aligned with Common Core Standards:**

- Focus on understanding fundamentals of reading and writing for the purpose of proper communication with others
- Divided into three core areas:

**The Conventions (Grammar and Vocabulary):** Developing command of English grammar conventions—including basic parts of speech, conjunctions, tense, and sentence structure; making appropriate use of capitalization and punctuation; understanding correct spellings for appropriate words and identifying misspellings.

**The Words (Vocabulary):** Developing an ever-increasing understanding of words and their meanings; using sentence-level context clues to understand meanings of a word; understanding relationships between words—including synonyms, homonyms and antonyms; identifying root words, prefixes and suffixes and using them to determine word meanings; developing understanding of figurative language; categorizing words by common themes and arranging them in order of intensity (i.e., *thin, slender, skinny, scrawny*)

**The Method (Reading and Writing):** Writing opinion, informative, and narrative pieces of increasing complexity in language and thinking; using tools and resources to review, revise, and edit pieces of writing; participating in research and gathering information through a variety of sources; demonstrating understanding of basic organization and features of text; recognizing distinguishing features of sentences; developing comprehension and recognition of words, sentences, and entire sections of text; applying phonics, context clues and other techniques to increase comprehension and understanding of words, sentences and sections of text.

### **How We Live and How We Express—Social Studies and Fine Arts from a Humanistic Approach**

- Combining Social Studies and Fine Arts with ELA to provide a humanistic lens for exploration of cultures
- **How We Live:** Social Studies divided into three main components:

**Foundations:** Exploring development of the humanities by analyzing World, U.S. and North Carolina history through text and literature

**Citizenship:** Developing a basic understanding of civics and government

**Ordinations:** Exploring cultures of the past through mythology and connecting moral/ethical themes with today's cultural norms

- **How We Express:** Using music and art to analyze the cultures and ideas of other ways of life and gain a greater understanding of one's own identity and how to express it artistically.

## **Appendix: Curriculum Design Outline for 1-5 Math and Science—Math Exploration**

- An integrated approach to teaching fundamental math (*The Skills*), science (*The Method*) and technology (*The Tools*) learning objectives
- Problem-based learning activities will highlight scientific concepts while developing mathematical thinking skills and understanding how to use technology appropriately

*The purpose of the integrated approach to math learning is to help students develop higher order reasoning skills based around science and math, preparing them for success in exploring more complex ideas in higher grades. Students are exposed to technology so they will be proficient with using it by that time.*

### **The Skills—Key Math Skills Aligned with Common Core Content Standards:**

**Number and Operation:** Understanding the place value system; using place value in counting and arithmetic operations; developing an understanding of decimals and fractions as numbers and how to operate with them; increasing command of standard arithmetic operations on whole numbers, decimals and fractions.

**Operations and Algebraic Thinking:** Understanding the fundamental nature of all arithmetic operations; developing relationships between basic arithmetic operations; identifying and generalizing patterns in number sequences and arithmetic; working with basic equations.

**Measurement and Data:** Measuring lengths indirectly by iterating length; writing and telling time; measuring and estimating lengths using units of measurement; working proficiently with time and money; representing and interpreting data with basic structures; applying concepts of measurement and estimation to solve a variety of problems; extending measurement to geometry.

**Geometry:** Reasoning with shapes and their attributes—including recognizing and drawing shapes with given parameters and understanding relationships between sets of figures (i.e. triangles, quadrilaterals, etc); drawing and identifying lines, angles and shapes and classifying shapes by properties of lines and angles.

### **The Methods and The Tools—A Scientific Approach to Math Learning using Technology**

- Common Core Standards and NCTM Standards for Math Practice are highlighted through scientific exploration, research, presentation and communication
- Science concepts (*The Methods*) divided into three main categories:

**Physical Science:** Understanding matter and its states; investigating basics of forces and motion; exploring the nature of sound; understanding electricity and magnetism.

**Earth/Environmental Science:** Understanding the basic structures of the planet; exploring rocks, minerals, and soil composition; exploring the solar system and how its structure relates to our planet; understanding weather, climate, and evolution of landforms.

**Life Science:** Understanding plants and their life cycles; connecting planetary systems to life cycles of plants and animals; understanding connections between various forms of life; exploring the human body, nutrition, and food

- Technology (*The Tools*): Learning proper use of technology for gathering, collecting, representing and analyzing information, as well as ethics of technology use.

## Appendix: Curriculum Design Outline for 6-12 Language Arts and Social Studies—The Lore and the Legend

- Integrated approach to both English/Language Arts (*The Lore*) and Social Studies/History (*The Legend*)
- Crossover in reading assignments to feature non-fiction/historical texts as well as research projects that utilize skills in each area.
- Therapeutic synthesis focused around the three main points (Perspective, Identification and Empathy)

### The Lore--English/Language Arts Aligned with Common Core Standards

*The purpose of this integrated approach is to create impassioned citizens that can effectively understand their place in the world relative to the present, and connect how both their own past, as well as the history of the world, play a unique role in shaping the culture that governs their personal identity.*

- Focus on understanding the need to understand other peoples' stories and the need to tell our own

- Divided into three primary components centered on 6-12 ELA Common Core Standards:  
***The Tools:*** Understanding use of English language conventions of grammar and usage when speaking and/or writing; making appropriate use of capitalization, punctuation and spelling; using context clues to determine/clarify the meaning of unknown and/or multiple-meaning words; understanding word relationships; acquiring and using a range of academic domain-specific words and phrases; producing clear and coherent writing.

***The Heart:*** Writing narratives to develop real or imagined experiences or events using effective technique; expressing and exploring one's emotions and points of view through multiple writing styles; producing creative writing with effective use of literary devices that clearly transmits one's thoughts, ideas, and/or emotions.

***The Mind:*** Presenting information, findings, and supporting evidence that readers can follow and understand; evaluating a speaker's point of view, reasoning, and use of evidence and/or rhetoric; writing arguments to support claims in an analysis of substantive topics or texts; drawing evidence from literary or informational texts to support analysis, reflection, and/or research.

### The Legend—Integrating History and Social Studies through Literature

- Focus on encouraging students to understand the context of the past relative to the present
- Divided into three primary Social Studies components:

***Foundations—U.S./World History and Literature from Ancient to Modern:*** exploring humanities through literature and informational text; establishing connections between historic events in the past and the culture of the present; manifesting a point of view on an event or idea of cultural importance

***Citizenship—Civics/Government:*** Understanding of how various forms of human civilization, including our own, have been governed and how our current political system works; analyzing the nature and purpose of various constitutions; understanding the distinctive characteristics of American society; developing a firm sense of citizenship, rights and responsibilities of the citizen, and the nature of civic life.

***Ordinations—Culture, Religion and Mythology:*** Exploring the culture and development of various world faiths; understanding the context of religion and myth in culture; analyzing mythology and religious texts to develop understanding on systems of ethics and morality; comparing and contrasting one's own moral and ethical perspective to that of other faiths and cultures.

## Appendix: Curriculum Design Outline for 6-12 Mathematics, Science, and Technology—The Formula

- An integrated approach to teaching mathematics and science
- Divided into three core components:
  - Developing key curriculum math skills aligned with the Common Core Standards (*The Tools*);
  - Enhancing critical thinking, logical reasoning and objective problem solving abilities (*The Mind*);
  - Integrating math with science and technology using modern applications (*The Connections*)

*These Content Standards for Math relate to tools used in scientific endeavors. The standards in green represent the direct point of juxtaposition between science and math—using measurements and data analysis to investigate problems, which extends to higher order mathematical skills. The result is to teach students that math is simply a language for communicating complex ideas related directly to science.*

### The Tools—Key Skills Aligned with the Common Core Content Standards:

**Number Sense:** Understanding numbers, interchangeable ways of representing them, and relationships among numbers and number systems; understanding meanings of operations and how they relate; and computing fluently with all appropriate sets of numbers.

**Algebra:** Understanding patterns, relations and functions; representing and analyzing mathematical situations and structures symbolically; using mathematical models to represent and understand quantitative relationships; and analyzing change in various contexts.

**Geometry:** Analyzing characteristics and properties of two- and three-dimensional geometric shapes and develop mathematical arguments about geometric relationships; specify locations and describe spatial relationships using coordinate geometry; applying transformations and using symmetry to analyze mathematical situations; and using visualization, spatial reasoning and geometric modeling to solve problems.

**Data Analysis/Probability:** Formulating questions that can be addressed with data and collecting, organizing and displaying relevant data to answer them; selecting and using appropriate statistical methods to analyze data; developing and evaluating inferences and predictions that are based on data; and understanding/applying basic concepts of probability.

**Measurement:** Understanding measurable attributes of objects and the units, systems, and processes of measurement; and applying appropriate techniques, tools, and formulas to determine measurements.

### The Mind—Critical Thinking Skills Aligned with the Common Core Practice Standards:

**Inquiry and Problem Solving:** Using inquiry to develop questions/problems to be analyzed and solved; building new knowledge through problem solving; solving problems that arise in contextual situations, using various strategies and adaptations.

**Reasoning and Proof:** Recognizing reasoning and proof as fundamental aspects of mathematics and science; making and investigating hypotheses and conjectures; developing and evaluating mathematical/scientific arguments and proofs/experiments; selecting and using various types of reasoning and methods of proof/experimentation.

*As with the Content Standards, while the Practice Standards are connected to Math, all of these concepts are crucial to being able to analyze, interpret, and communicate scientific ideas with others. Conversely, science provides a lens for a PBL approach to Math. Technology is used to increase students' understanding of the role of technology in collecting, analyzing, and representing information. All of these goals align perfectly with the 21<sup>st</sup> Century Learning Standards and ISTE Standards.*

**Communication:** Organizing and consolidating thinking through communication; communicating mathematical/scientific thinking coherently and clearly to others; analyzing and evaluating the mathematical/scientific thinking and strategies of others; and using the language of math/science to express ideas precisely.

**Connections:** Recognizing and using connections among scientific or mathematical ideas; understanding how scientific/mathematical ideas interconnect and build on one another to produce a coherent whole; recognizing and applying skills in contexts secondary to mathematics/science; developing understanding of historical, as well as personal/social, perspectives of mathematics/science.

**Representation:** Creating and using representations to organize, record, and communicate data and mathematical/scientific ideas; selecting, applying and translating among representations to solve problems; using representations to model and interpret phenomena; creating appropriate experiments and scientific models to communicate, investigate and extend scientific ideas and concepts.

### **The Connections—Science and Technology Context Integration**

**Physical Science:** Understanding the operations of forces and properties of motion; developing sense of the structure and properties of matter; understanding matter as atoms and interpreting atomic structures; creating connections between, energy, matter, and charge.

**Life Science:** Understanding the origins of life; creating connections between the cell, molecular basis of heredity, and biological evolution; understanding the interdependence of organisms, matter, energy and organization and living systems.

**Earth and Environmental Science:** Understanding the fundamental functions of Earth's systems; creating connections between matter, energy, and Earth's mechanics; analyzing the origin and evolution of planet Earth and the solar system; developing awareness of the planet's environmental systems.

**Technology:** Understanding the need for technology and its appropriate uses; knowing effective strategies for using technology in work; analyzing how technology affects our life and how it relates to science and mathematics.

## 1. Creativity and Innovation

Students demonstrate creative thinking, construct knowledge, and develop innovative products and processes using technology.

- a. Apply existing knowledge to generate new ideas, products, or processes
- b. Create original works as a means of personal or group expression
- c. Use models and simulations to explore complex systems and issues
- d. Identify trends and forecast possibilities

## 2. Communication and Collaboration

Students use digital media and environments to communicate and work collaboratively, including at a distance, to support individual learning and contribute to the learning of others.

- a. Interact, collaborate, and publish with peers, experts, or others employing a variety of digital environments and media
- b. Communicate information and ideas effectively to multiple audiences using a variety of media and formats
- c. Develop cultural understanding and global awareness by engaging with learners of other cultures
- d. Contribute to project teams to produce original works or solve problems

## 3. Research and Information Fluency

Students apply digital tools to gather, evaluate, and use information.

- a. Plan strategies to guide inquiry
- b. Locate, organize, analyze, evaluate, synthesize, and ethically use information from a variety of sources and media
- c. Evaluate and select information sources and digital tools based on the appropriateness to specific tasks
- d. Process data and report results

## 4. Critical Thinking, Problem Solving, and Decision Making

Students use critical thinking skills to plan and conduct research, manage projects, solve problems, and make informed decisions using appropriate digital tools and resources.

- a. Identify and define authentic problems and significant questions for investigation
- b. Plan and manage activities to develop a solution or complete a project
- c. Collect and analyze data to identify solutions and/or make informed decisions
- d. Use multiple processes and diverse perspectives to explore alternative solutions





## 5. Digital Citizenship

Students understand human, cultural, and societal issues related to technology and practice legal and ethical behavior.

- a. Advocate and practice safe, legal, and responsible use of information and technology
- b. Exhibit a positive attitude toward using technology that supports collaboration, learning, and productivity
- c. Demonstrate personal responsibility for lifelong learning
- d. Exhibit leadership for digital citizenship

## 6. Technology Operations and Concepts

Students demonstrate a sound understanding of technology concepts, systems, and operations.

- a. Understand and use technology systems
- b. Select and use applications effectively and productively
- c. Troubleshoot systems and applications
- d. Transfer current knowledge to learning of new technologies

NETS-S © 2007 International Society for Technology in Education.  
ISTE® is a registered trademark of the International Society for Technology in Education.

# Appendix: Eliada Academy Day Class Schedule

Elementary Homeroom A2		Middle-/High Homeroom C1	Lunch 12:00	
8:06 to 8:40 Homeroom				
8:40-10:00 (80)	9:00-9:25 Spelling 9:25-10:15 Math Explorations 10:15-10:25 Restroom Break	<u>Skills and Peer-Relations C1</u>		
10:00-11:20 (80)	10:25-10:45 Recess 10:45-11:20 Discovering Humanities	<u>English C1</u>		
11:20-12:00 (40)	11:20-11:50 Recess 11:50-12:00 Wash Hands	<u>THE FORMULA C1</u>		
Lunch 12:00				
Elementary <u>QUIET SKILLS/Read Aloud_A2</u>		<u>THE FORMULA C1</u>	Unsafe Lunch Bunch C1:: Stingray Lunch A1:	
12:30-1:15 (45)				
1:15-2:45 (90)	Monday	Tuesday	Wednesday	Thursday
	<u>Cooking class A3</u>	<u>TASC A1</u>	<u>TASC A1</u>	<u>TASC A1</u>
	<u>NYPUM Front Porch</u>	<u>NYPUM Front Porch</u>	<u>NYPUM Front Porch</u>	<u>NYPUM Front Porch</u>
	<u>Paws With a Purpose/The Artist's Way D1</u>	<u>Swimming B1</u>	<u>Skills D1</u>	<u>Swimming Computer Lab</u>
	<u>Fitness Center B1</u>	<u>Gym A3</u>	<u>Fitness Center/Climbing A2</u>	<u>Mindfulness B1</u>
	<u>Expectation Station C1</u>	<u>Expectation Station D1</u>	<u>Expectation Station -B1</u>	<u>Expectation Station C1</u>
				<u>Friday</u>
				<u>TASC A1</u>
				<u>NYPUM Front Porch</u>
				<u>Girl Staff Computer Lab</u>
				<u>Fitness Center/Climbing B1</u>
				<u>Expectation Station -C1</u>

\*During the last 15-20 minutes of 4<sup>th</sup> Block Treatment activities, please debrief the class and the day with your students. What you learned, what would you do differently, finalize Balance Sheets, verify Green Tickets, Get a drink of water, restroom, review expectations for PM line up outside.

Appendix: Eliada Academy Class Schedule-Residential

GRADE	CUMMINGS Elementary	COTTAGE	REUTER Middle School/High School CO-ED	LESSONS
	<p>8:30-10:15</p> <p><b>1</b></p> <p>RECREATION</p>			
	<p>10:15-11:15</p> <p><b>2</b></p> <p>ENRICHMENT</p>			
	<p>LUNCH</p> <p>11:15-12:00</p>			
	<p>12:00-1:30</p> <p><b>3</b></p> <p>THE LORE AND THE LEGEND</p>			
	<p>1:30-3:00</p> <p><b>4</b></p> <p>THE FORMULA</p>			
	<p>TEACHER PLANNING</p> <p>10:15-11:00</p>			

**Appendix: PILLARS OF SCHOOL CULTURE**

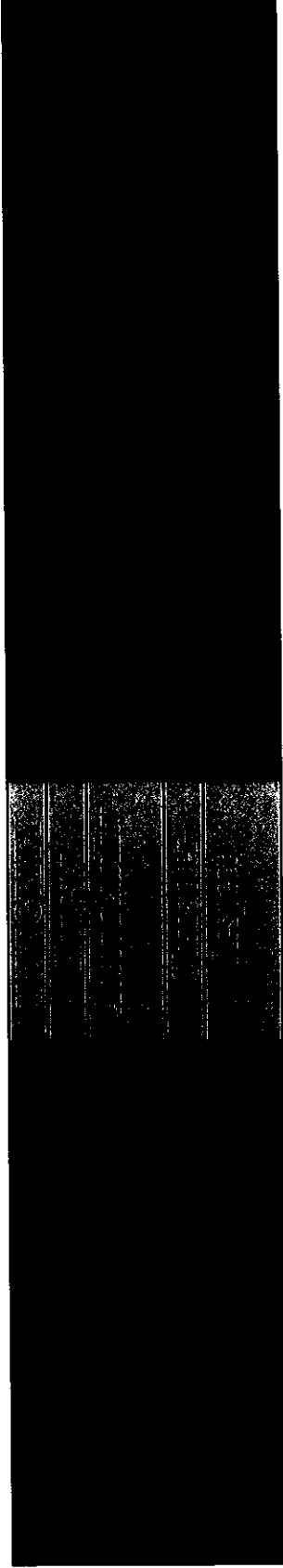

# BASI

Outcome: 45% of students will improve by 1 or more grade levels during placement at Day Treatment.

## Descriptive Statistics

	N	Minimum	Maximum	Mean
Admission BASI Math Grade	46	.00	12.90	4.4957
Discharge BASI Math Grade	27	.00	13.00	4.0556
Admission BASI Reading Grade	46	.00	12.90	5.4739
Discharge BASI Reading Grade	29	.00	13.00	5.8897
Admission BASI Writing Grade	46	.00	12.90	4.9609
Discharge BASI Writing Grade	28	.00	13.00	5.9643
Valid N (listwise)	26			

Pre and post BASI test scores produce highly significant results for reading and writing. Drastic improvement is accomplished in both subjects. On average, for reading, students increased close to one grade level. And, for writing, students increased an entire grade level. **In reading, 85% of students increased at least one grade level. And, in writing, 61% of students increased at least one grade level.** Math, however, was the only subject that did not produce a positive change. On average, student's scores dropped approximately half a grade level. This change was not significant.

BASI	Grade Change	Significance Level
Math	decrease of .2 (less than 1 grade level)	Not Significant
Reading	Increase of 3 grade levels	Highly Significant
Writing	Increase of 2 grade levels	Highly Significant

## Group Statistics

Developmental Disorder		N
Admission BASI MTH recoded	Yes	8
	No	27
Admission BASI RDG recoded	Yes	8
	No	27
Admission BASI WRT recoded	Yes	6
	No	27

## Independent Samples Test

		Sig.
Admission BASI MTH recoded	Equal variances assumed	.165
Admission BASI RDG recoded	Equal variances assumed	.907
Admission BASI WRT recoded	Equal variances assumed	.014

By running independent sample t-test, we are able to determine if there is a relationship between 2 unrelated variables. The independent sample t-test is very similar to the ANOVA (refer to page 11 for details). What the t-test uncovered was that having a dual diagnosis of a developmental disorder was directly related to how well a student scores on the writing portion of the BASI at admission. For math and reading, there was not a significant relationship between having a developmental disorder and admission BASI scores. With a larger sample size, we might find a more significant relationship.

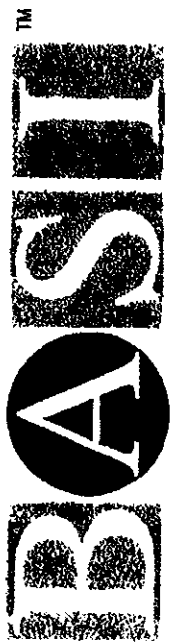

# Basic Achievement Skills Inventory

## Student Summary Report: BASI Level 2

Achilles N. Barcos, PhD

Teacher: Bacon, Rena O.  
 Class/Group: 20108  
 School: Elvada Academy  
 District Code: 000277

Student: [Redacted]  
 Student ID: 201016714  
 Birth Date: 11/08/1998  
 Grade: 6

Timed: Yes  
 ESL Student: No  
 Accommodations: No  
 Test Date: 06/10/2011  
 Report Date: 02/08/2012  
 Form: B  
 Norms: Spring / 6th Grade

Composite of Subtests	SS	Confidence Interval	Safe	GSV	GE	AE
Reading Total	79	73-88	8	93		
Vocabulary	80	72-93	9	93	<3.0	<8-0
Reading Comprehension	87	79-98	19	94	3.2	8-0
Written Language Total	78	71-88	7	93		
Spelling	85	77-97	16	96	<3.0	<8-0
Language Mechanics	79	71-92	8	90	<3.0	<8-0
Math Total	64	58-77	0.8	78		
Math Computation	61	56-80	0.5	71	<3.0	<8-0
Math Application	72	65-88	3	82	<3.0	<8-0

BASI results are presented in the tables on this page. Standard scores compare performance with that of other 6th grade students in a national sample. Confidence intervals indicate the range of standard scores that is likely to include the true score. Percentile (%ile) scores indicate what percentage of the norm group scored as well as or better than. The GSV score is a measure of raw performance on a particular subtest or composite. The GSV scale for a subtest or composite is consistent across BASI forms and levels, making GSV scores useful for measuring change over time. GSV scores from different subtests or composites cannot be compared.

The tables below present results for the various achievement areas included in each of the six BASI subtests. The results shown are percentage correct (PC) and a rating of his performance relative to that of other examinees. These results identify the areas in which he excels and those in which he might need help. They can also help track progress if he takes the BASI test again.

SS = Standard Score (mean = 100, SD = 15) %ile = Percentile Rank GSV = Growth Scale Value GE = Grade Equivalent AE = Age Equivalent PC = Percentage Correct

Achievement Area	PC	Performance
Vocabulary	28	Below Average
Meaning, content, idiom	40	Below Average
Similar words, synonyms, antonyms	19	Below Average
Prefixes, suffixes, roots	44	Average
Verbal analogies	20	Average
Reading Comprehension	30	Below Average
LITERAL COMPREHENSION	17	Below Average
Order of events, steps in process	25	Average
Relevant details	25	Average
Written directions	0.0	Below Average
INFERENTIAL COMPREHENSION	34	Average
Theme, plot elements	25	Below Average
Cause, effect	100	Above Average
Probable outcome	25	Average
Inferences, conclusions	0.0	Below Average
Purpose, technique, tone	25	Average
Fact, opinion, persuasion, tone	38	Average

Achievement Area	PC	Performance
Spelling	43	Below Average
Prefixes and suffixes	38	Below Average
Commonly misspelled words	43	Average
Spelling rules	50	Below Average
Language Mechanics	26	Below Average
Internal punctuation	13	Average
GRAMMAR	28	Below Average
Nouns, pronouns, articles	0.0	Below Average
Subject/verb agreement	25	Below Average
Adjectives, adverbs	0.0	Below Average
Double negatives	100	Above Average

Achievement Area	PC	Performance
Math Computation	7	Below Average
Whole numbers	14	Below Average
Fractions	0.0	Below Average
Decimals, order of operations, percents	17	Below Average
Integers, absolute value	0.0	Below Average
Algebra	0.0	Below Average
Math Application	23	Below Average
Whole numbers, money	25	Below Average
Fractions, proportions	0.0	Below Average
Decimals, percents	20	Average
Measurement	43	Below Average
Algebra	50	Average
Statistics, probability	0.0	Below Average

ITEM RESPONSES

1:	2:	2:	2:	3:	2:	4:	2:	5:	1:	6:	3:	7:	2:	8:	1:	9:	2:	10:	/	11:	2:	12:	2:	13:	1:	14:	1:	15:	1:
16:	1:	17:	2:	18:	2:	19:	1:	20:	1:	21:	1:	22:	2:	23:	2:	24:	3:	25:	2:	26:	3:	27:	2:	28:	3:	29:	1:	30:	1:
31:	4:	32:	2:	33:	1:	34:	4:	35:	3:	36:	3:	37:	3:	38:	4:	39:	2:	40:	2:	41:	2:	42:	2:	43:	2:	44:	2:	45:	2:
46:	1:	47:	2:	48:	3:	49:	3:	50:	2:	51:	1:	52:	2:	53:	2:	54:	1:	55:	3:	56:	3:	57:	1:	58:	1:	59:	2:	60:	2:
61:	3:	62:	2:	63:	4:	64:	4:	65:	2:	66:	2:	67:	3:	68:	3:	69:	3:	70:	3:	71:	3:	72:	1:	73:	3:	74:	4:	75:	4:
76:	2:	77:	2:	78:	1:	79:	3:	80:	3:	81:	2:	82:	1:	83:	3:	84:	/	85:	2:	86:	1:	87:	2:	88:	3:	89:	1:	90:	1:
91:	3:	92:	3:	93:	3:	94:	1:	95:	2:	96:	2:	97:	1:	98:	1:	99:	1:	100:	1:	101:	1:	102:	2:	103:	1:	104:	2:	105:	1:
106:	2:	107:	1:	108:	1:	109:	1:	110:	1:	111:	1:	112:	1:	113:	2:	114:	1:	115:	1:	116:	2:	117:	3:	118:	1:	119:	3:	120:	1:
121:	2:	122:	3:	123:	1:	124:	1:	125:	4:	126:	3:	127:	1:	128:	3:	129:	2:	130:	2:	131:	1:	132:	4:	133:	4:	134:	2:	135:	2:
136:	3:	137:	4:	138:	2:	139:	2:	140:	3:	141:	3:	142:	3:	143:	3:	144:	1:	145:	3:	146:	3:	147:	2:	148:	1:	149:	2:	150:	3:
151:	4:	152:	2:	153:	1:	154:	2:	155:	2:	156:	2:	157:	4:	158:	1:	159:	2:	160:	2:	161:	4:	162:	1:	163:	2:	164:	3:	165:	2:
166:	3:	167:	1:	168:	3:	169:	3:	170:	3:	171:	3:	172:	4:	173:	4:	174:	4:	175:	4:	176:	3:	177:	4:	178:	2:	179:	2:	180:	3:
181:	2:	182:	3:	183:	1:	184:	1:	185:	3:	186:	2:	187:	2:	188:	1:	189:	3:	190:	4:	191:	4:	192:	2:	193:	3:	194:	3:	195:	1:
196:	3:	197:	1:	198:	3:	199:	1:	200:	1:	201:	1:	202:	2:	203:	2:	204:	1:	205:	3:	206:	2:	207:	1:	208:	2:	209:	3:	210:	1:
211:	4:	212:	1:	213:	1:	214:	1:	215:	1:	216:	1:	217:	1:	218:	2:	219:	2:	220:	2:	221:	2:	222:	1:	223:	3:				

Note. Item responses are listed in the order that the items are presented to the client.

Vocabulary	1-40
Spelling	41-80
Language Mechanics	81-119
Reading Comprehension	120-163
Math Computation	164-193
Math Application	194-223

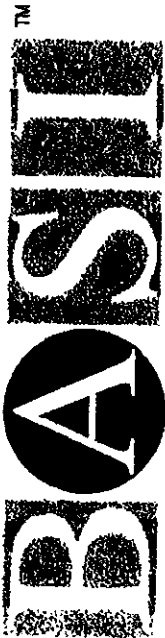

**Basic Achievement Skills Inventory**

**Parent's Summary Report: BASI Level 2**

Achilles N. Bardos, PhD

Student ID: 201016714  
 Birth Date: 11/06/1998  
 Grade: 6

Teacher: Bacon, Rena O.  
 Class/Group: 21108  
 School: Eliada Academy  
 District Code: 000277

Timed: Yes  
 ESL Student: No  
 Accommodations: No  
 Test Date: 06/10/2011  
 Report Date: 02/08/2012  
 Form: B  
 Norms: Spring / 6th Grade

Composite Subtest	Performance	National Percentile
Reading Total	Below Average 8	75
Vocabulary	Below Average 9	75
Reading Comprehension	Below Average 19	75
Written Language Total	Below Average 7	75
Spelling	Below Average 16	75
Language Mechanics	Below Average 8	75
Math Total	Below Average 0.8	75
Math Computation	Below Average 0.5	75
Math Application	Below Average 3	75

**To the parent or guardian of Chaston Garrison:**

Chaston took the Basic Achievement Skills Inventory (BASITM) on June 10, 2011. His performance is summarized in the table at the left.

Chaston's performance in the Reading Total area was in the Below Average range compared to the performance of a national sample of 6th grade students. His percentile score indicates that his Reading Total score was equal to or higher than that of 9% of the students in the national comparison group. The Reading Total area includes the Vocabulary and Reading Comprehension subtests. The Vocabulary subtest has questions that involve recognizing the meaning of words in isolation and in sentences, identifying synonyms and antonyms, and analyzing verbal analogies. The Reading Comprehension subtest has questions involving literal comprehension (for example, identifying details and facts in a passage) and inferential comprehension (for example, determining cause and effect relationships, making inferences, and drawing conclusions based on the information in a passage). Chaston's Vocabulary score was in the Below Average range, and his Reading Comprehension score was in the Below Average range. Chaston's performance in the Written Language Total area was in the Below Average range compared to the performance of a national sample of 6th grade students. His percentile score indicates that his Written Language Total score was equal to or higher than that of 7% of the students in the national comparison group. The Written Language Total area includes the Spelling and Language Mechanics subtests. The Spelling subtest has questions that involve identifying correctly spelled and misspelled words. It also includes sight words, commonly misspelled words, and words with affixes. The Language Mechanics subtest has questions that involve recognizing and correctly using nouns, verbs, adjectives, and adverbs and following grammar and syntax rules. Chaston's Spelling score was in the Below Average range, and his Language Mechanics score was in the Below Average range.

Chaston's performance in the Math Total area was in the Below Average range compared to the performance of a national sample of 6th grade students. His percentile score indicates that his Math Total score was equal to or higher than 0.8% of the students in the national comparison group. The Math Total area includes the Math Computation and Math Application subtests. The Math Computation subtest has questions that involve applying the four basic arithmetic operations to whole numbers, fractions, and decimals, and simplifying numerical expressions and algebraic equations. The Math Application subtest has questions that involve solving word problems using the four basic arithmetic operations, reading and interpreting data presented in graphs and tables, measuring shapes, utilizing skills of estimation and algebra, and demonstrating knowledge of measurement principles as they relate to length, weight, perimeter, and money. Chaston's Math Computation score was in the Below Average range, and his Math Application score was in the Below Average range.

If you need help interpreting these scores, please talk to Chaston's teacher.

**Comments:**

---



---



---



---



---



---



---



---



---



---



# Appendix: Eliada Student Education Plan

## Part I: Student Information

<b>Student Name:</b>	<b>Date of Birth:</b>	<b>Race/Ethnicity:</b>	<b>Gender:</b>	<b>Place of Residence:</b>
<b>Eliada Student ID Number:</b>	<b>Current Placement:</b>	<b>Date of Admission:</b>	<b>Student Diagnoses:</b>	
<b>Last School Attended:</b>	<b>Last Date of Attendance:</b>	<b>Current Grade:</b>	<b>Pre-Existing Education Plans:</b> <input type="checkbox"/> IEP <input type="checkbox"/> 504 Plan <input type="checkbox"/> Other	
<b>School Phone:</b>				
<b>Student Strengths and Interests:</b>				
<b>Learning Style, Identified Intelligences and Known Effective Learning Strategies (IEP/504 Accommodations if applicable):</b>				

# Appendix: Eliada Student Education Plan

## Part II: Assessment Results, Current Grades and Observational Notes

Assessment Results					
Test Domain:	BASI Standard Score (mean = 100; SD=15)	BASI Percentile Rank	BASI GSV	EOC/EOG:	Results:
Reading:					
Writing:					
Mathematics:					
<b>Current Scores:</b>		<b>English/Language Arts:</b>		<b>Math:</b>	
		<b>Drama/Performing Arts:</b>			
<b>Observational Notes from Teachers:</b>					

# Appendix: Eliada Student Education Plan

## Part III: Intervention Plan and Monitoring

	School Intervention					
Subject:	Specific Needs	Intervention/Strategies	Monitoring Date	Monitoring Status		
				Insufficient Progress	Some Progress	Mastery
				<input type="checkbox"/>	<input type="checkbox"/>	<input type="checkbox"/>
				<input type="checkbox"/>	<input type="checkbox"/>	<input type="checkbox"/>
				<input type="checkbox"/>	<input type="checkbox"/>	<input type="checkbox"/>
				<input type="checkbox"/>	<input type="checkbox"/>	<input type="checkbox"/>
				<input type="checkbox"/>	<input type="checkbox"/>	<input type="checkbox"/>
				<input type="checkbox"/>	<input type="checkbox"/>	<input type="checkbox"/>
				<input type="checkbox"/>	<input type="checkbox"/>	<input type="checkbox"/>
				<input type="checkbox"/>	<input type="checkbox"/>	<input type="checkbox"/>
				<input type="checkbox"/>	<input type="checkbox"/>	<input type="checkbox"/>
				<input type="checkbox"/>	<input type="checkbox"/>	<input type="checkbox"/>
				<input type="checkbox"/>	<input type="checkbox"/>	<input type="checkbox"/>
				<input type="checkbox"/>	<input type="checkbox"/>	<input type="checkbox"/>
				<input type="checkbox"/>	<input type="checkbox"/>	<input type="checkbox"/>
				<input type="checkbox"/>	<input type="checkbox"/>	<input type="checkbox"/>
				<input type="checkbox"/>	<input type="checkbox"/>	<input type="checkbox"/>
<b>Intervention Status:</b>						
				<input type="checkbox"/> Insufficient; plan needs revision <input type="checkbox"/> Sufficient; continue with plan <input type="checkbox"/> Mastery; plan completed and new plan to be drafted		

# Appendix: Eliada Student Education Plan

## Part IV: Student/Teacher Reflections, Advocate Strategies and Communications

	Date:
<b>Student/Teacher Reflections:</b>	Date:
	Date:
	Date:
<b>Advocate Strategies:</b>	
	Case Manager and Advocate have received a copy of Student Learning Plan by: Email <input type="checkbox"/> Conference <input type="checkbox"/> Date:
<b>Communications</b>	Case Manager and Advocate have received a copy of Student Learning Plan after each monitoring update: Email <input type="checkbox"/> Conference <input type="checkbox"/> Date:      Email <input type="checkbox"/> Conference <input type="checkbox"/> Date:

Instructor Signature/Date: \_\_\_\_\_ Instructor Signature/Date: \_\_\_\_\_

Advocate Signature/Date: \_\_\_\_\_ Student Signature/Date: \_\_\_\_\_

Eliada Homes, Inc.  
Case Manager Contact Log

Client Name: [REDACTED]

Date	Comments	Initials
11/2/11	Emailed team about setting up schedule for nurse to monitor [REDACTED] blood pressure. Emailed with Janice, and Marie regarding this.	CD
11/7/11	Met with Dr. Kiratzis to discuss integration of primary care and behavioral health care. Dr. Kiratzis reviewed discharge paperwork from Copestone. Discussed her current behaviors as well as the documentation needed by cardiologist to have her blood pressure taken daily for next several weeks. He will continue to review information and see [REDACTED] at next appt.	CD
11/8/11	Made TFC referrals to Carolina Therapeutic Services and Professional Parenting.	CD
11/8/11	Emailed DSS to give her info about referrals made.	CD
11/8/11	Spoke with Susan Swan, EC Curriculum Manager with Buncombe County Schools. Explained situation with [REDACTED] and need to return to public school and testing that is needed. She will get back to me after researching some options.  Emailed team with this info.	CD
11/14/11	Emailed daily updates to foster parents.	CD
11/16/11	Emailed team about updates, concerns of sleeping.	CD
11/18/11	Emailed foster parents update from today's behaviors.	CD
11/21/11	Emailed foster parents update from morning. also emailed regarding questions they had about Friday's balance sheet.	CD
11/30/11	Emailed with foster parents updates on behaviors.	CD
12/7/11	Emailed DSS and TFC about incident today in day treatment.	CD
12/8/11	Emailed DSS about incident today.	CD
12/8/11	Emailed Sara and Janice update and suggested we meet asap to discuss needs and strategies for this child.	CD
12/9/11	Emailed foster parents update on behaviors today.	CD

# Transition Plan I

12/12/11	After special staffing, emailed DSS and GAL with Eliada's recommendations from special staffing and info for next CFT on 12/21.	CD
12/14/11	Spoke with Susan Swan, EC Curriculum Manager with Buncombe Co Schools. Let her know that [REDACTED] plan may have changed and our team meeting is scheduled for the 21 <sup>st</sup> . let her know I will contact her after January 2 <sup>nd</sup> to let her know the plan for [REDACTED]	CD
12/20/11	Emailed GAL – responded to her email about discharge planning.	CD

Eliada Homes, Inc.  
Case Manager Contact Log

Client Name: [REDACTED]

Date	Comments	Initials
1/5/12	Emailed Susan Swan, EC Curriculum Manager for Buncombe co Schools, to begin to discuss transition planning for [REDACTED] (IEP)	CD
1/9/12	Spoke with Pam Demos, Program Placement Specialist for Eblen Intermediate School, and gave her info regarding [REDACTED] transition. Let her know I would drop all of [REDACTED] school records off at the school today. She will review the paperwork and call me back. Pam cell: 776-2252	CD
1/11/12	Left message for Bethany Brooks, school social worker, returning her call. Cell: 777-1276	CD
1/12/12	Spoke with Bethany Brooks at Eblen. Gave her update on [REDACTED] – authorization, transition planning and what her needs are. She will speak to Susan Swan about what needs to happen next and get back to me.	CD
1/18/12	Spoke with Bethany Brooks to discuss transition planning further. She is going to contact her supervisor about who can serve as surrogate parent on IEP for [REDACTED].	CD
1/24/12	Emailed team about [REDACTED] behaviors this morning. gave them updates throughout day.	CD
1/26/12	Spoke with Cindy Hicks, GAL, about transition planning and long term planning.	CD
1/26/12	Emailed Kim, TFC, about motivation plan that TASC wants to set up for [REDACTED]	CD
1/30/12	Emailed with Kim, TFC, about concerns and behaviors in day treatment. Strategized regarding behaviors.	CD
1/31/12	Emailed Kim regarding upcoming appts for [REDACTED]	CD
2/6/12	Spoke with Kim King about updates, transition plan for school. discussed at length pro's and con's of public school vs a private school.  Emailed team about re-scheduling today's team meeting. re-scheduled for Tuesday Feb 14 <sup>th</sup> @ 1pm.	CD
2/7/12	Spoke with Bethany Brooks (Eblen 255-5757) School Social Worker about transition planning. Let her know team was considering a	CD

Transition  
Plan I

	private school (DSS is). She offered to come to next CFT and let team know what school can and can't offer [REDACTED] if she were to return.	
2/9/12	Spoke with Kim Hoyle, TFC, about [REDACTED] not wanting to go to after school today. strategized this.	CD



Eliada Homes, Inc.  
Case Manager Contact Log

Client Name:                     

Date	Comments	Initials
2/15/12	Emailed Kim, TFC, and therapist about update of behaviors from 4 <sup>th</sup> block yesterday.	CD
2/16/12	Emailed Kim, DSS, about today's RI with <u>                    </u> . Gave information about this.	CD
2/16/12	Spoke with Kim, TFC, about today's behaviors in detail.	CD
2/21/12	Emailed Kim TFC about <u>                    </u> being absent – she is sick.	CD
2/22/12	Emailed with Kim TFC, <u>                    </u> still sick, will be absent.	CD
2/27/12	Spoke with Kim about <u>                    </u>	CD
2/28/12	Gave Kim update on <u>                    </u> day.	CD
2/29/12	Gave Kim and Sara update on <u>                    </u> day.	CD
3/1/12	Spoke with Bethany Brooks, School Social Worker, from Eblen Intermediate School. She was surprised that nobody from school has contacted me. She will follow up asap and have someone call me by Monday to set up a meeting. Cell: 777-1276 School: 255-5757	CD
3/2/12	Emailed Kim with update from today's orthodontist appt.	CD
3/5/12	Emailed Kim update from today's behaviors in day treatment.	CD
3/7/12	Left Bethany Brooks a voice mail message stating that I have not been contacted yet by anyone from the school to set up a meeting for <u>                    </u> .	CD
3/8/12	Bethany returned my call suggesting I call Pam Demos who is over IEP at Eblen. She apologized for no one getting back to me.	CD
3/8/12	Pam Demos – EC at Eblen Intermediate School (776-2252). Left message for her to return my call.	CD

# Transition Plan I

3/8/12	3:30pm attempted to call Pam Demos at the school but she had left for day.	CD
3/9/12	Spoke with Pam Demos at Eblen. Discussed setting up meeting, Kim Hoyle needing to go enroll [redacted] at the school, concerns and transition planning. Going to meet her Monday morning at 9am at the school to tour the classroom and get our opinion on best transition for [redacted]. Will try to meet around 15 <sup>th</sup> or 16 <sup>th</sup> , to possibly begin half days around the 23 <sup>rd</sup> .	CD
3/9/12	Emailed Kim King, DSS, to update her on info from above.	CD
3/12/12	Met with Pam Demos at Eblen Intermediate School. She gave me a tour of the self contained classroom and 6 <sup>th</sup> grade hall. We discussed what they need from us (academic info and safety plan). discussed other needs for [redacted] and about setting up an IEP meeting this week.	CD
3/14/12	Spoke with Pam Demos. The EC teacher is coming here tomorrow morning to discuss her IEP and talk with the teachers here, as well as meet [redacted]. Set an IEP meeting for Tuesday 3/20 @ 10am.	CD
3/14/12	Emailed Kim at DSS and Cindy GAL update on school and IEP progress.	CD
3/15/12	Met with Michelle Watkins – she came to Eliada to meet [redacted] and to meet with teacher for information for IEP. Discussed history, triggers, strategies, information, etc.	CD

# Transition Plan I

IEP meeting at Eblen Intermediate School for [REDACTED]

3/20/2012

10:00am

Present: Program Placement Specialist for Eblen, Pam Demos; Head of the Special Education Department for Eblen, Karen Morgan; teacher at Eblen, Michelle Watkins; Principal at Eblen, Melanie Collins; Surrogate Parent, Bonnie King; and Eliada staff – Therapeutic Foster Consultant, Janice Irwin; Therapist, Sara Taylor; Day Treatment case manager, Carri Devlin and Therapeutic Foster Parents, Kim and Alvin Hoyle.

The team reviewed all aspects of the IEP. Ms. Watkins facilitated the goals for [REDACTED] IEP. The team discussed crisis planning and intervention strategy planning.

Discussed transition planning: [REDACTED] will start half days at Eblen on Monday March 26<sup>th</sup>. She will stay at Eblen until 12:15pm, and then return to Eliada Day Treatment for remainder of day. (She will be eating lunch at Eblen). Kim Hoyle will take [REDACTED] to school on Monday March 26<sup>th</sup>. Discussed that she will be riding the bus beginning Tuesday March 27<sup>th</sup>. There is a transportation support person on this bus to provide support to [REDACTED]. Team discussed what non-academic classes [REDACTED] would be most interested in and would be the most successful in. Team agreed that would be Art, Drama and possibly Music/Chorus.

Friday, March 23<sup>rd</sup>, Kim Hoyle will take [REDACTED] to Eblen to visit the class, tour the school and eat lunch with her class. She will also stay and do a group activity with the class if she is feeling comfortable.

Eblen is on spring break and therefore closed April 2<sup>nd</sup> – April 6<sup>th</sup>.

The treatment and IEP team will re-convene on Monday April 9<sup>th</sup> at 11:00am, to discuss how the first week of transition went (progress and concerns) and what will be the next step in this transition planning.

Carri Devlin, QP  
Eliada Day Treatment

# Transition Plan I

Transition Meeting at Eblen Intermediate School for [REDACTED]

4/9/2012

11:00am

Present: Program Placement Specialist for Eblen, Pam Demos; Head of the Special Education Department for Eblen, Karen Morgan; [REDACTED] teacher at Eblen, Michelle Watkins; Principal at Eblen, Melanie Collins; School Social Worker, Bethany Brooks; Surrogate Parent, LuAnn Harris; and Eliada Staff – Therapeutic Foster Care Consultant, Janice Irwin; Day Treatment Case Manager, Carri Devlin; and Therapeutic Foster Parents, Kim and Alvin Hoyle.

The team discussed update from the previous week that [REDACTED] did half days. She was on spring break last week, and Kim Hoyle continued academics with her while at home. Ms. Watkins reports that [REDACTED] did really well with half days the week of March 26<sup>th</sup>-30<sup>th</sup>. She was interacting, answering questions and very well behaved. However, Ms. Watkins reports that [REDACTED] has slept all morning in class before the meeting today. With this concern, Ms. Watkins recommended that [REDACTED] continue with half days for at least another week. The Eliada staff expressed concern that this may feel like a regression to [REDACTED] to have to come back to Eliada after being told she would start full days today. The team agreed that one more week of half days and Kim will pick up at 12:45pm, and continue academics at home. The team spoke about [REDACTED] history of sleeping (avoidance and symptoms of PTSD) and that she most always is alert by mid-morning. (Ms. Watkins called the teacher at 11:15am, and [REDACTED] was awake and had went to the computer lab with her class). [REDACTED] will begin full days on Thursday April 19<sup>th</sup>.

Next IEP/Transition meeting will be Tuesday April 24<sup>th</sup> at Eblen Intermediate School. The IEP can be updated to reflect full days and the team can discuss updates at this time.

Carri Devlin, QP  
Eliada Day Treatment

**Child and Family Team Minutes**

Eliada Homes, Inc

Student: [REDACTED] Date: 12-14-11 Record #: 417638

Child and Family Team Members Present:

Parent(s): [REDACTED] - mom

Custodian: \_\_\_\_\_

Family Member(s): \_\_\_\_\_

Community Support Case Manager: \_\_\_\_\_

Eliada Staff: Carri Devlin - Day Treatment

Others: \_\_\_\_\_

Child and Family Team Members Absent: \_\_\_\_\_

List Newly Identified STRENGTHS of the child and family: funny, smart, good hygiene

Items Reviewed:

- |  |   |
|--|---|
| 1. Residential Treatment Goal Progress               | 10. Educational/Vocational                          |
| 2. Day Treatment Goal Progress                       | 11. Cultural Needs (review form) & Related Services |
| 3. TFC Goal Progress                                 | 12. In House Care Coverage (TFC only)               |
| 4. Transition/Permanency Planning (see attachment)   | 13. Safety & Support Plans                          |
| 5. Individual, Group & Family Therapy                | 14. Participation in enhanced/community services    |
| 6. Family goals and Progress                         | 15. Other Team Member Agenda Items                  |
| 7. Review & Planning of Therapeutic Leave/Visitation |   |
| 8. Medical/Dental Concerns                           |   |
| 9. Changes to Diagnosis/ Medication Changes          |   |

④ Discussed transition plan - doing half days with Enka Middle School when semester starts around January 17<sup>th</sup>. Carri has contacted 8<sup>th</sup> grade counselor Kate Bradford about transition plan. She will speak to 7<sup>th</sup> grade former counselor and Principal about his transition. She asked that I call her back week of January 9<sup>th</sup>, and we can set up a transition meeting. Carri will follow up with Kate to confirm he does not have an IEP - mom feels he had an IEP before although our records do not show one.

## Transition Plan 2

⑧ Mom reports he is taking medication consistently. His next med eval is first of January. Dr did not want to make any changes from last evaluation. Mom will report continued fidgetiness. She reports Dr may increase at next med eval. Will discuss the transition with the dr.

② Day Tx goal progress: Symptoms of anxiety - Has made great improvements with goal. Worries have decreased in frequency and intensity. [REDACTED] is less nervous - physical sensations have improved - such as using restroom constantly. Handwriting has improved. Concentration has improved - although other symptoms (associated with attentional difficulties) do affect level of concentration. Also affects communication a bit more. Learning stress management skills - to not let environment affect behaviors and decision making ability. Symptoms of attentional difficulties - struggles most with these behaviors. [REDACTED] remains very impulsive - talks out, easily distracted, instigating toward peers, and touching things. Doing a lot better to complete tasks and assignments.

Transition  
Plan 2

More organized - especially with completing and turning in homework.

Symptoms of ODD - working on, and making progress with not deliberately annoying peers but continues to need to work on. [REDACTED] makes inappropriate comments to peers, and they can also be rude and hurtful. This feeds into peer relationship target. [REDACTED] needs to be aware of his interactions with peers. Continuing to work on complying with rules and structure. Does better with accepting responsibility for behaviors.

⑥ Doing better in the home. Mom feels he is making progress - getting along better with sisters. For this reason, she is not interested in any In Home Services when [REDACTED] discharged from day treatment.

⑤ Individual therapy at Eliada Day Treatment, with clinician.

④ No changes.

Transition  
Plan 2

**REVIEW OF MEDICAID/PRIVATE INSURANCE/ HEALTH CHOICE/SSI COVERAGE (Complete SSI for Non-DSS Custody Clients Only)**

Type of Coverage:  Medicaid  Private Insurance \_\_\_\_\_  
 Health Choice  
 SSI

SSI Progress: \_\_\_\_\_

Current Expiration Date: \_\_\_\_\_

Verified By Case Manager: \_\_\_\_\_  
Signature and Date

**Planned Use of Restrictive Intervention (N/A TFC)**

Review Use of Restrictive Intervention Since Last Team Meeting: \_\_\_\_\_  
N/A

Should Planned Use of Restrictive Intervention be Continued?  Yes  No

Transportation: \_\_\_\_\_

Date & Time of Next Review: To be scheduled with Enka Middle School

**In signing below, we agree to hold confidential what is shared within the Child and Family Team.**

**Signatures and Title of Team Members In Agreement**  
Carmel Derlin @ P. Chiada  
[Redacted] - client  
[Redacted] - mom

**Signature and Title of Team Members In Disagreement (please also state concerns)**  
\_\_\_\_\_  
\_\_\_\_\_  
\_\_\_\_\_  
\_\_\_\_\_



Transition  
Plan 2

Transition and Discharge Plan  
Eliada Homes, Inc.

Client Name: [REDACTED]  
Record #: 417638  
Date: 12.14.11

Current Placement: [REDACTED] attends Eliada Day Treatment and lives at home with his mother.

Long Term Plan: To return to public school.

Step Down Plan:

What	Task	Who is responsible	Target Date	Progress
Eliada Service				
Community Support	To set [REDACTED] up with Targeted Case Management when discharged from Eliada Day Treatment.	Carri Devlin, Eliada Day Treatment Case Manager		No longer applicable due to services changes in NC. Will set [REDACTED] up with outpatient services.
DSS	N/A			
Court	N/A			
Intensive In Home	To look at possibility of setting family back up with Intensive In Home upon discharge.	Carri Devlin, Eliada Day Treatment Case Manager	Spring 2012	Mom stated she is not interested in this service, but will continue to present upon discharge.
Med Management				[REDACTED] receives medication management through outside psychiatrist.

# Transition Plan 2

What	Task	Who is responsible	Target Date	Progress
Formal Supports	To explore supports within [redacted] family and community that would be available after discharge.	Carri Devlin, Eliada Day Treatment Case Manager [redacted] mom	Spring 2012	
School	To work with Enka Middle School for transition planning.	Carri Devlin, Eliada Day Treatment Case Manager	Spring 2012	Carri will contact Enka Middle School about a possible transition plan of doing half days next semester. 12/14/11: spoke with Kate Bradford at Enka Middle School and began to discuss transition planning.
IEP	No IEP			
Family				
Respite				
Other				
Other				
Other				



# Transition Plan 2

## Child and Family Team Minutes Eliada Homes, Inc

Student: [REDACTED] Date: 1-13-12 Record #: 417638

Child and Family Team Members Present:  
Parent(s): [REDACTED]  
Custodian: \_\_\_\_\_  
Family Member(s): \_\_\_\_\_  
Community Support Case Manager: \_\_\_\_\_  
Eliada Staff: Carr Devlin - Day Tx  
Others: Kate Bradford - counselor, Stephen Earwood - VP (EMS Staff)

Child and Family Team Members Absent: \_\_\_\_\_  
List Newly Identified STRENGTHS of the child and family: continued support, family support.

### Items Reviewed:

- |  |   |
|--|---|
| 1. Residential Treatment Goal Progress               | 10. Educational/Vocational                          |
| 2. Day Treatment Goal Progress                       | 11. Cultural Needs (review form) & Related Services |
| 3. TFC Goal Progress                                 | 12. In House Care Coverage (TFC only)               |
| 4. Transition/Permanency Planning (see attachment)   | 13. Safety & Support Plans                          |
| 5. Individual, Group & Family Therapy                | 14. Participation in enhanced/community services    |
| 6. Family goals and Progress                         | 15. Other Team Member Agenda Items                  |
| 7. Review & Planning of Therapeutic Leave/Visitation |   |
| 8. Medical/Dental Concerns                           |   |
| 9. Changes to Diagnosis/ Medication Changes          |   |

### \* Transition Meeting at Enka Middle School

④ [REDACTED] will be starting partial days at Enka Middle School on Tuesday January 17. He will complete the first two blocks at Enka and then come to Eliada Day Treatment for the remainder of the day. His transportation will need to pick him up at Enka Middle at 10:15 am to be taken to Eliada. The team agreed to meet again on Monday, February 27 @ 1:30 pm to discuss how

## Transition Plan 2

transition is going. Team can decide at this meeting to either add an additional block or have [REDACTED] return full day.

Team discussed Triggers / Strategies form that was given to School by Day Treatment. Discussed with [REDACTED] what his triggers were going to be, and how he could work on these without getting in trouble.

Discussed the bus situation and if [REDACTED] will need assigned seating. Mr. Earwood is going to follow up on this and check in with the bus driver, because he is a new driver. Suggested to [REDACTED] he think about what / and how much he wants to tell his peers (because they will inquire about where he has been).

Mr. Earwood will be meeting with [REDACTED] first thing Tuesday morning - to get him checked in, schedule in hand and deliver him to his first class.

⑥ [REDACTED] reports no concerns with home. continuing to do well in family activities. [REDACTED] is not interested in setting up

Intensive In Home Services for after discharge from Day Treatment.

⑤ Individual therapy at Ehiada - with clinician Anne Garren. Team will be setting up therapy for [REDACTED] with outside therapist when discharged. Continuing to discuss options for a therapist.

④ [REDACTED] will continue to receive medication management at Asheville Mission Children's with Dr. Poplowski.

⑪ [REDACTED] reports they do not need to be absent ([REDACTED]) on Monday January 16 for Martin Luther King holiday. They have no plans. I let [REDACTED] know absence would be excused as a cultural consideration, if they decided to.

② Day Tx goal progress: [REDACTED] will continue to work on goals of symptoms of anxiety, symptoms of attentional difficulties and symptoms of ODD during this time of transition.

## Transition Plan 2

██████ continues to struggle with impulse control, staying on task and completing assignments. Has periods of being hyperactive. Progress with decreasing physical sensations of anxiety and decreasing frequency and intensity of worries. Team will closely monitor these symptoms during transition.

communication has improved - although Quavien continues to need to work on when it is appropriate times to ask questions (also to use listening skills and not have teacher repeat instructions, etc). ██████ continues to need to work on distractibility - he can easily get off task by peers who are off task.

Decrease in oppositional behaviors. Seeing improvements with following rules, respect for adults and authority and accepting responsibility (mom reports a continued improvement in accepting responsibility at home!). Needs to continue to be self-aware of peer relations - not bullying, laughing or encouraging off task behaviors.

Transition Plan 2

**REVIEW OF MEDICAID/PRIVATE INSURANCE/ HEALTH CHOICE/SSI COVERAGE (Complete SSI for Non-DSS Custody Clients Only)**

Type of Coverage:  Medicaid  Private Insurance \_\_\_\_\_  
 Health Choice  
 SSI

SSI Progress: \_\_\_\_\_

Current Expiration Date: \_\_\_\_\_

Verified By Case Manager: \_\_\_\_\_  
Signature and Date

**Planned Use of Restrictive Intervention (N/A TFC)**

Review Use of Restrictive Intervention Since Last Team Meeting: \_\_\_\_\_  
N/A

Should Planned Use of Restrictive Intervention be Continued?  Yes  No

Transportation: \_\_\_\_\_

Date & Time of Next Review: Feb. 27 @ 1:30 @ Enka Middle School

**In signing below, we agree to hold confidential what is shared within the Child and Family Team.**

**Signatures and Title of Team Members In Agreement**  
Cari & Derlin P. Eliada  
- client  
- mom

**Signature and Title of Team Members In Disagreement (please also state concerns)**  
\_\_\_\_\_  
\_\_\_\_\_  
\_\_\_\_\_  
\_\_\_\_\_



Transition 2

Transition and Discharge Plan  
Eliada Homes, Inc.

Client Name: [REDACTED]

Record #: 417638

Date: 1.13.12

**Current Placement:** [REDACTED] attends Eliada Day Treatment and lives at home with his mother.

**Long Term Plan:** To return to public school.

**Step Down Plan:** [REDACTED] will begin a transition plan with Enka Middle. He will start doing a partial day with Enka Middle on Tuesday January 17<sup>th</sup>.

What	Task	Who is responsible	Target Date	Progress
<b>Eliada Service</b>				
<b>Community Support</b>	To set [REDACTED] up with Targeted Case Management when discharged from Eliada Day Treatment.	Carri Devlin, Eliada Day Treatment Case Manager		No longer applicable due to services changes in NC. Will set [REDACTED] up with outpatient services.
<b>DSS</b>	N/A			
<b>Court</b>	N/A			
<b>Intensive In Home</b>	To look at possibility of setting family back up with Intensive In Home upon discharge.	Carri Devlin, Eliada Day Treatment Case Manager	Spring 2012	Mom stated she is not interested in this service, but will continue to present upon discharge.
<b>Med Management</b>				[REDACTED] receives medication management through outside psychiatrist.

# Transition Plan 2

at	Task	Who is responsible	Target Date	Progress
Normal Supports	To explore supports within [redacted] family and community that would be available after discharge.	Carri Devlin, Eliada Day Treatment Case Manager [redacted] mom	Spring 2012	Family has church involvement. [redacted] father has also been more involved in his life and [redacted] has been staying with him on weekends.
School	To work with Enka Middle School for transition planning.	Carri Devlin, Eliada Day Treatment Case Manager	Spring 2012	Team met today at Enka Middle School to discuss transition planning.
IEP	No IEP			
Family				
Respite				
Other				
Other				
Other				

# Transition Plan 2

Eliada Homes, Inc.  
Case Manager Contact Log

Client Name: [REDACTED]

Date	Comments	Initials
12/14/11	Spoke with Susan Swan, EC Curriculum Manager with Buncombe Co Schools, and she confirmed that <span style="background-color: black; color: black;">[REDACTED]</span> does not have an IEP.	CD
12/19/11	Spoke with mom about current updates and Christmas gifts.	CD
12/20/11	Met with mom who came to campus to pick up gifts.	CD
12/28/11	Spoke with mom, who informed me of a special diet that <span style="background-color: black; color: black;">[REDACTED]</span> must begin. Discussed with director who stated mom can bring in his food if planned lunch does not meet requirements.	CD
12/30/11	Followed up with mom about <span style="background-color: black; color: black;">[REDACTED]</span> diet. Let her know that it is okay for her to send lunch. she will need to provide dr note for this.	CD
1/6/12	Spoke with Kate Bradford – counselor at Enka Middle – to touch base about transition planning. 670-5010	CD
1/6/12	Left mom message to let her know of dates/times available for a transition meeting with Enka Middle.	CD
1/9/12	Mom returned call with her availability. Left message for Kate at EMS to let her know we could do Friday @ 12:30pm for a transition meeting.	CD

# Transition Plan 2

## Child and Family Team Minutes Eliada Homes, Inc

Student: [REDACTED] Date: 2-27-12 Record #: 417638

Child and Family Team Members Present:

Parent(s): [REDACTED] - mom

Custodian: \_\_\_\_\_

Family Member(s): \_\_\_\_\_

Community Support Case Manager: \_\_\_\_\_

Eliada Staff: Carri Devlin - DTx

Others: Nvr. Earwood - AP, Kate Bradford - counselor, Ali Hostetter - School Social Worker

Child and Family Team Members Absent: \_\_\_\_\_

List Newly Identified STRENGTHS of the child and family: Very positive successful transition with Enka Middle, positive support system

### Items Reviewed:

- |  |   |
|--|---|
| 1. Residential Treatment Goal Progress               | 10. Educational/Vocational                          |
| 2. Day Treatment Goal Progress                       | 11. Cultural Needs (review form) & Related Services |
| 3. TFC Goal Progress                                 | 12. In House Care Coverage (TFC only)               |
| 4. Transition/Permanency Planning (see attachment)   | 13. Safety & Support Plans                          |
| 5. Individual, Group & Family Therapy                | 14. Participation in enhanced/community services    |
| 6. Family goals and Progress                         | 15. Other Team Member Agenda Items                  |
| 7. Review & Planning of Therapeutic Leave/Visitation |   |
| 8. Medical/Dental Concerns                           |   |
| 9. Changes to Diagnosis/ Medication Changes          |   |

\* Transition Meeting at Enka Middle School.

- ④ Assistant Principal would like to see [REDACTED] start full days this Thursday March 1. Thursday they rotate the schedule and this would be good timing. [REDACTED] last day at Eliada will be Wednesday February 29. School reports [REDACTED] is doing well at school. Going full days will require [REDACTED] to be in gym - which will be with about 80 ~~day~~ boys. Discussed less supervision in this class.

## Transition Plan 2

██████████ will really need to step up - watch boundaries, follow rules and have positive peer interactions.

██████████ has been doing partial days between day treatment and Enka Middle since January 17. He started with one class at Enka. Then on February 7, ██████████ began half days. This slow transition proved to be very successful for ██████████. He was able to return to day treatment and process the morning with treatment staff.

⑤ Ms. Hostetter, School Social Worker, will make a referral for ██████████ to have a school based counselor. He was receiving therapy at Eliada Day Treatment.

⑧ No medical concerns. Continues to do well on current medication.

② ██████████ will continue to work on goals of symptoms of anxiety, symptoms of attentional difficulties, and symptoms of ODD during this time of final transition. ██████████ has made significant improvements with communication

## Transition Plan 2

skills, decreasing frequency and intensity of worries, improving with concentrating, impulse control, decreasing activity level, complying with rules and structure and especially accepting responsibility for behavior. [REDACTED] has transitioned to day treatment from public school and has been very focused on himself. He has made great strides with peer relations—often encouraging peers and avoiding off task behaviors by peers. [REDACTED] handwriting has improved, he does not have issues of having to go to bathroom (due to anxiety) like when he first came to day tx. [REDACTED] has worked to not deliberately annoy his peers. He gives positive, constructive feedback as well as accepts it. He has followed rules when coming from public school (not bringing anything he's not suppose to have).

⑥ Positive progress at home. Following rules, accepting responsibility, getting along with sisters, and doing chores.

Transition Plan 2

**REVIEW OF MEDICAID/PRIVATE INSURANCE/ HEALTH CHOICE/SSI COVERAGE (Complete SSI for Non-DSS Custody Clients Only)**

Type of Coverage:  Medicaid  Private Insurance \_\_\_\_\_  
 Health Choice  
 SSI

SSI Progress: \_\_\_\_\_

Current Expiration Date: \_\_\_\_\_

Verified By Case Manager: \_\_\_\_\_  
Signature and Date

**Planned Use of Restrictive Intervention (N/A TFC)**

Review Use of Restrictive Intervention Since Last Team Meeting: \_\_\_\_\_  
N/A

Should Planned Use of Restrictive Intervention be Continued?  Yes  No

Transportation: \_\_\_\_\_

Date & Time of Next Review: [redacted] discharge date 2/29/12

**In signing below, we agree to hold confidential what is shared within the Child and Family Team.**

**Signatures and Title of Team Members In Agreement**

Case of Derlin RP DTX  
[redacted] mom  
[redacted] - Client

**Signature and Title of Team Members In Disagreement (please also state concerns)**

\_\_\_\_\_  
\_\_\_\_\_  
\_\_\_\_\_  
\_\_\_\_\_

# Transition Plan 2

## Transition and Discharge Plan Eliada Homes, Inc.

**Client Name:** ██████████

**Record #:** 417638

**Date:** 2.27.12

**Current Placement:** ██████████ attends Eliada Day Treatment and lives at home with his mother.

**Long Term Plan:** To return to public school.

**Step Down Plan:** ██████████ will transition full days at public school. His last day at Eliada Day Treatment will be February 29<sup>th</sup>. He will begin full days March 1<sup>st</sup>.

What	Task	Who is responsible	Target Date	Progress
<b>Eliada Service</b>				
<b>Community Support</b>	To set ██████████ up with Targeted Case Management when discharged from Eliada Day Treatment.	Carri Devlin, Eliada Day Treatment Case Manager		No longer applicable due to services changes in NC. Will set ██████████ up with outpatient services. School Social Worker, Alli Hostetter, will set ██████████ up with a school based therapist.
<b>DSS</b>	N/A			
<b>Court</b>	N/A			
<b>Intensive In Home</b>	To look at possibility of setting family back up with Intensive In Home upon discharge.	Carri Devlin, Eliada Day Treatment Case Manager	Spring 2012	Mom stated she is not interested in this service upon discharge.
<b>Med Management</b>				██████████ receives medication management through outside psychiatrist.



Transition  
Plan 2

What	Task	Who is responsible	Target Date	Progress
Formal Supports	To explore supports within [redacted] family and community that would be available after discharge.	Carri Devlin, Eliada Day Treatment Case Manager [redacted] mom	Spring 2012	Family has church involvement. [redacted] father has also been more involved in his life and [redacted] has been staying with him on weekends.
School	To work with Enka Middle School for transition planning.	Carri Devlin, Eliada Day Treatment Case Manager	Spring 2012	Team met today at Enka Middle School to finalize transition planning.
IEP	No IEP			
Family				
Respite				
Other				
Other				
Other				

# Transition Plan 2

Eliada Homes, Inc.  
Case Manager Contact Log

Client Name: \_\_\_\_\_

Date	Comments	Initials
1/17/12	Spoke with mom about today's transition with Enka Middle. Also let her know that [redacted] ran into another peer while tossing the football and got a swollen eye. Nurse was contacted and checked it out.	CD
1/20/12	Met with Kate Bradford, school counselor, to check in regarding how transition was going.	CD
2/6/12	Spoke with Kate Bradford. Enka wants to add another class on to transition plan (starting tomorrow) since they have had a class rotation. She reports [redacted] is doing well with transition.	CD
2/6/12	Spoke with mom about this transition – all set up. reminded her of days EA is closed and plan for that.	CD
2/27/12	Transition meeting at Enka Middle School.	CD

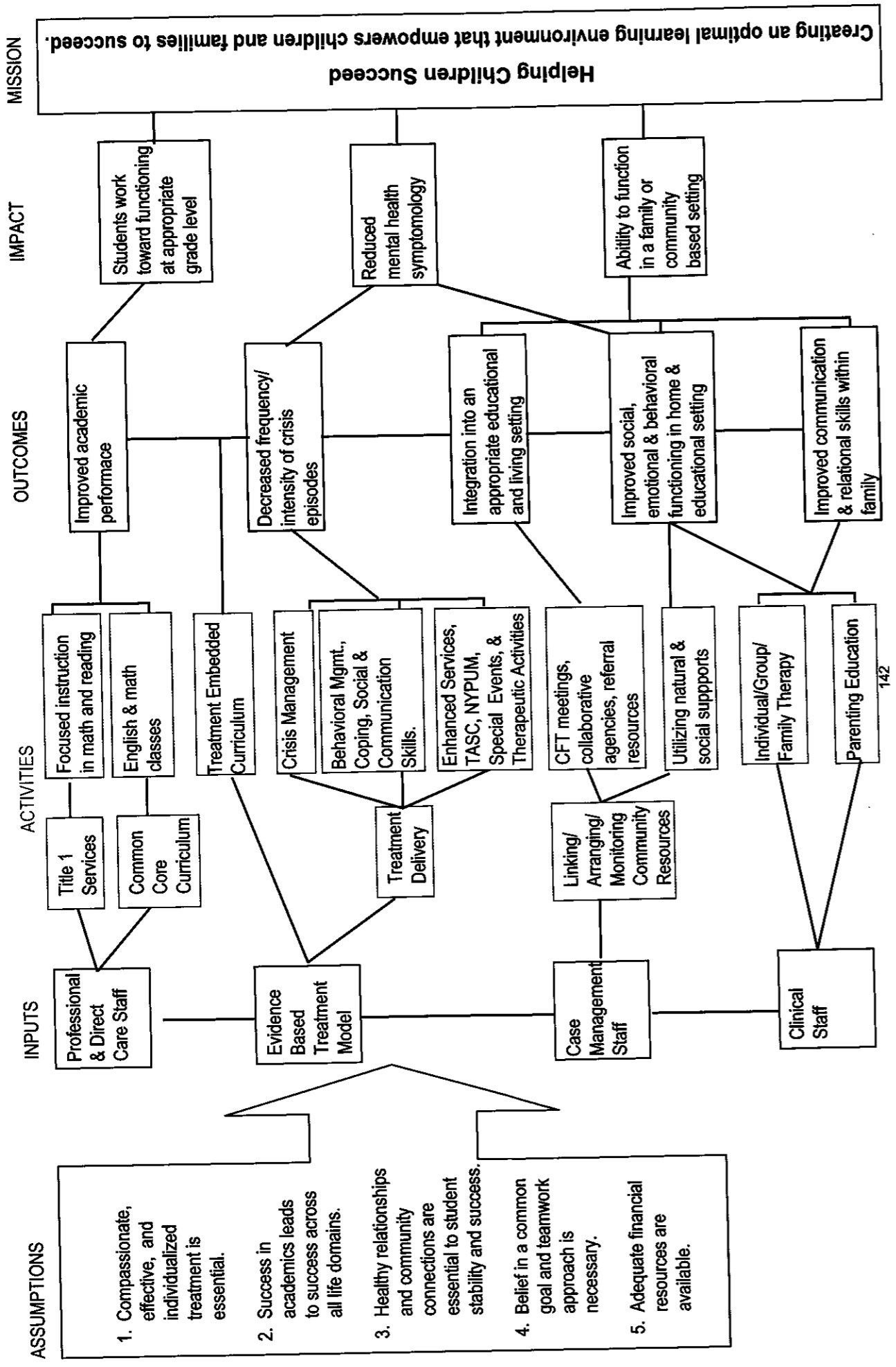

# Attachment: Calendar 2013-2014

**Eliada  
Academy**  
School Starts  
August 19, 2013

August 2013						
Su	Mo	Tu	We	Th	Fr	Sa
				1	2	3
4	5	6	7	8	9	10
11	12	13	14	15	16	17
18	19	20	21	22	23	24
25	26	27	28	29	30	31

September 2013	October 2013	November 2013	December 2013																																																																																																																																																																																																																																																																																																																									
<table border="1"> <thead> <tr> <th>Su</th><th>Mo</th><th>Tu</th><th>We</th><th>Th</th><th>Fr</th><th>Sa</th></tr> </thead> <tbody> <tr><td>1</td><td>2</td><td>3</td><td>4</td><td>5</td><td>6</td><td>7</td></tr> <tr><td>8</td><td>9</td><td>10</td><td>11</td><td>12</td><td>13</td><td>14</td></tr> <tr><td>15</td><td>16</td><td>17</td><td>18</td><td>19</td><td>20</td><td>21</td></tr> <tr><td>22</td><td>23</td><td>24</td><td>25</td><td>26</td><td>27</td><td>28</td></tr> <tr><td>29</td><td>30</td><td></td><td></td><td></td><td></td><td></td></tr> </tbody> </table>	Su	Mo	Tu	We	Th	Fr	Sa	1	2	3	4	5	6	7	8	9	10	11	12	13	14	15	16	17	18	19	20	21	22	23	24	25	26	27	28	29	30						<table border="1"> <thead> <tr> <th>Su</th><th>Mo</th><th>Tu</th><th>We</th><th>Th</th><th>Fr</th><th>Sa</th></tr> </thead> <tbody> <tr><td></td><td></td><td>1</td><td>2</td><td>3</td><td>4</td><td>5</td></tr> <tr><td>6</td><td>7</td><td>8</td><td>9</td><td>10</td><td>11</td><td>12</td></tr> <tr><td>13</td><td>14</td><td>15</td><td>16</td><td>17</td><td>18</td><td>19</td></tr> <tr><td>20</td><td>21</td><td>22</td><td>23</td><td>24</td><td>25</td><td>26</td></tr> <tr><td>27</td><td>28</td><td>29</td><td>30</td><td>31</td><td></td><td></td></tr> </tbody> </table>	Su	Mo	Tu	We	Th	Fr	Sa			1	2	3	4	5	6	7	8	9	10	11	12	13	14	15	16	17	18	19	20	21	22	23	24	25	26	27	28	29	30	31			<table border="1"> <thead> <tr> <th>Su</th><th>Mo</th><th>Tu</th><th>We</th><th>Th</th><th>Fr</th><th>Sa</th></tr> </thead> <tbody> <tr><td></td><td></td><td></td><td></td><td></td><td>1</td><td>2</td></tr> <tr><td>3</td><td>4</td><td>5</td><td>6</td><td>7</td><td>8</td><td>9</td></tr> <tr><td>10</td><td>11</td><td>12</td><td>13</td><td>14</td><td>15</td><td>16</td></tr> <tr><td>17</td><td>18</td><td>19</td><td>20</td><td>21</td><td>22</td><td>23</td></tr> <tr><td>24</td><td>25</td><td>26</td><td>27</td><td>28</td><td>29</td><td>30</td></tr> </tbody> </table>	Su	Mo	Tu	We	Th	Fr	Sa						1	2	3	4	5	6	7	8	9	10	11	12	13	14	15	16	17	18	19	20	21	22	23	24	25	26	27	28	29	30	<table border="1"> <thead> <tr> <th>Su</th><th>Mo</th><th>Tu</th><th>We</th><th>Th</th><th>Fr</th><th>Sa</th></tr> </thead> <tbody> <tr><td>1</td><td>2</td><td>3</td><td>4</td><td>5</td><td>6</td><td>7</td></tr> <tr><td>8</td><td>9</td><td>10</td><td>11</td><td>12</td><td>13</td><td>14</td></tr> <tr><td>15</td><td>16</td><td>17</td><td>18</td><td>19</td><td>20</td><td>21</td></tr> <tr><td>22</td><td>23</td><td>24</td><td>25</td><td>26</td><td>27</td><td>28</td></tr> <tr><td>29</td><td>30</td><td>31</td><td></td><td></td><td></td><td></td></tr> </tbody> </table>	Su	Mo	Tu	We	Th	Fr	Sa	1	2	3	4	5	6	7	8	9	10	11	12	13	14	15	16	17	18	19	20	21	22	23	24	25	26	27	28	29	30	31																																																																																																																																																					
Su	Mo	Tu	We	Th	Fr	Sa																																																																																																																																																																																																																																																																																																																						
1	2	3	4	5	6	7																																																																																																																																																																																																																																																																																																																						
8	9	10	11	12	13	14																																																																																																																																																																																																																																																																																																																						
15	16	17	18	19	20	21																																																																																																																																																																																																																																																																																																																						
22	23	24	25	26	27	28																																																																																																																																																																																																																																																																																																																						
29	30																																																																																																																																																																																																																																																																																																																											
Su	Mo	Tu	We	Th	Fr	Sa																																																																																																																																																																																																																																																																																																																						
		1	2	3	4	5																																																																																																																																																																																																																																																																																																																						
6	7	8	9	10	11	12																																																																																																																																																																																																																																																																																																																						
13	14	15	16	17	18	19																																																																																																																																																																																																																																																																																																																						
20	21	22	23	24	25	26																																																																																																																																																																																																																																																																																																																						
27	28	29	30	31																																																																																																																																																																																																																																																																																																																								
Su	Mo	Tu	We	Th	Fr	Sa																																																																																																																																																																																																																																																																																																																						
					1	2																																																																																																																																																																																																																																																																																																																						
3	4	5	6	7	8	9																																																																																																																																																																																																																																																																																																																						
10	11	12	13	14	15	16																																																																																																																																																																																																																																																																																																																						
17	18	19	20	21	22	23																																																																																																																																																																																																																																																																																																																						
24	25	26	27	28	29	30																																																																																																																																																																																																																																																																																																																						
Su	Mo	Tu	We	Th	Fr	Sa																																																																																																																																																																																																																																																																																																																						
1	2	3	4	5	6	7																																																																																																																																																																																																																																																																																																																						
8	9	10	11	12	13	14																																																																																																																																																																																																																																																																																																																						
15	16	17	18	19	20	21																																																																																																																																																																																																																																																																																																																						
22	23	24	25	26	27	28																																																																																																																																																																																																																																																																																																																						
29	30	31																																																																																																																																																																																																																																																																																																																										
<table border="1"> <thead> <tr> <th>January 2014</th> <th>February 2014</th> <th>March 2014</th> <th>April 2014</th> </tr> </thead> <tbody> <tr> <td> <table border="1"> <thead> <tr> <th>Su</th><th>Mo</th><th>Tu</th><th>We</th><th>Th</th><th>Fr</th><th>Sa</th></tr> </thead> <tbody> <tr><td></td><td></td><td></td><td>1</td><td>2</td><td>3</td><td>4</td></tr> <tr><td>5</td><td>6</td><td>7</td><td>8</td><td>9</td><td>10</td><td>11</td></tr> <tr><td>12</td><td>13</td><td>14</td><td>15</td><td>16</td><td>17</td><td>18</td></tr> <tr><td>19</td><td>20</td><td>21</td><td>22</td><td>23</td><td>24</td><td>25</td></tr> <tr><td>26</td><td>27</td><td>28</td><td>29</td><td>30</td><td>31</td><td></td></tr> </tbody> </table> </td> <td> <table border="1"> <thead> <tr> <th>Su</th><th>Mo</th><th>Tu</th><th>We</th><th>Th</th><th>Fr</th><th>Sa</th></tr> </thead> <tbody> <tr><td></td><td></td><td></td><td></td><td></td><td></td><td>1</td></tr> <tr><td>2</td><td>3</td><td>4</td><td>5</td><td>6</td><td>7</td><td>8</td></tr> <tr><td>9</td><td>10</td><td>11</td><td>12</td><td>13</td><td>14</td><td>15</td></tr> <tr><td>16</td><td>17</td><td>18</td><td>19</td><td>20</td><td>21</td><td>22</td></tr> <tr><td>23</td><td>24</td><td>25</td><td>26</td><td>27</td><td>28</td><td>29</td></tr> <tr><td>30</td><td>31</td><td></td><td></td><td></td><td></td><td></td></tr> </tbody> </table> </td> <td> <table border="1"> <thead> <tr> <th>Su</th><th>Mo</th><th>Tu</th><th>We</th><th>Th</th><th>Fr</th><th>Sa</th></tr> </thead> <tbody> <tr><td>2</td><td>3</td><td>4</td><td>5</td><td>6</td><td>7</td><td>8</td></tr> <tr><td>9</td><td>10</td><td>11</td><td>12</td><td>13</td><td>14</td><td>15</td></tr> <tr><td>16</td><td>17</td><td>18</td><td>19</td><td>20</td><td>21</td><td>22</td></tr> <tr><td>23</td><td>24</td><td>25</td><td>26</td><td>27</td><td>28</td><td>29</td></tr> <tr><td>30</td><td>31</td><td></td><td></td><td></td><td></td><td></td></tr> </tbody> </table> </td> <td> <table border="1"> <thead> <tr> <th>Su</th><th>Mo</th><th>Tu</th><th>We</th><th>Th</th><th>Fr</th><th>Sa</th></tr> </thead> <tbody> <tr><td></td><td></td><td></td><td>1</td><td>2</td><td>3</td><td>4</td></tr> <tr><td>5</td><td>6</td><td>7</td><td>8</td><td>9</td><td>10</td><td>11</td></tr> <tr><td>12</td><td>13</td><td>14</td><td>15</td><td>16</td><td>17</td><td>18</td></tr> <tr><td>19</td><td>20</td><td>21</td><td>22</td><td>23</td><td>24</td><td>25</td></tr> <tr><td>26</td><td>27</td><td>28</td><td>29</td><td>30</td><td></td><td></td></tr> </tbody> </table> </td> </tr> <tr> <td> <table border="1"> <thead> <tr> <th>May 2014</th> <th>June 2014</th> <th>July 2014</th> </tr> </thead> <tbody> <tr> <td> <table border="1"> <thead> <tr> <th>Su</th><th>Mo</th><th>Tu</th><th>We</th><th>Th</th><th>Fr</th><th>Sa</th></tr> </thead> <tbody> <tr><td></td><td></td><td></td><td></td><td>1</td><td>2</td><td>3</td></tr> <tr><td>4</td><td>5</td><td>6</td><td>7</td><td>8</td><td>9</td><td>10</td></tr> <tr><td>11</td><td>12</td><td>13</td><td>14</td><td>15</td><td>16</td><td>17</td></tr> <tr><td>18</td><td>19</td><td>20</td><td>21</td><td>22</td><td>23</td><td>24</td></tr> <tr><td>25</td><td>26</td><td>27</td><td>28</td><td>29</td><td>30</td><td>31</td></tr> </tbody> </table> </td> <td> <table border="1"> <thead> <tr> <th>Su</th><th>Mo</th><th>Tu</th><th>We</th><th>Th</th><th>Fr</th><th>Sa</th></tr> </thead> <tbody> <tr><td>1</td><td>2</td><td>3</td><td>4</td><td>5</td><td>6</td><td>7</td></tr> <tr><td>8</td><td>9</td><td>10</td><td>11</td><td>12</td><td>13</td><td>14</td></tr> <tr><td>15</td><td>16</td><td>17</td><td>18</td><td>19</td><td>20</td><td>21</td></tr> <tr><td>22</td><td>23</td><td>24</td><td>25</td><td>26</td><td>27</td><td>28</td></tr> <tr><td>29</td><td>30</td><td></td><td></td><td></td><td></td><td></td></tr> </tbody> </table> </td> <td> <table border="1"> <thead> <tr> <th>Su</th><th>Mo</th><th>Tu</th><th>We</th><th>Th</th><th>Fr</th><th>Sa</th></tr> </thead> <tbody> <tr><td></td><td></td><td>1</td><td>2</td><td>3</td><td>4</td><td>5</td></tr> <tr><td>6</td><td>7</td><td>8</td><td>9</td><td>10</td><td>11</td><td>12</td></tr> <tr><td>13</td><td>14</td><td>15</td><td>16</td><td>17</td><td>18</td><td>19</td></tr> <tr><td>20</td><td>21</td><td>22</td><td>23</td><td>24</td><td>25</td><td>26</td></tr> <tr><td>27</td><td>28</td><td>29</td><td>30</td><td>31</td><td></td><td></td></tr> </tbody> </table> </td> </tr> </tbody> </table> </td></tr></tbody></table>	January 2014	February 2014	March 2014	April 2014	<table border="1"> <thead> <tr> <th>Su</th><th>Mo</th><th>Tu</th><th>We</th><th>Th</th><th>Fr</th><th>Sa</th></tr> </thead> <tbody> <tr><td></td><td></td><td></td><td>1</td><td>2</td><td>3</td><td>4</td></tr> <tr><td>5</td><td>6</td><td>7</td><td>8</td><td>9</td><td>10</td><td>11</td></tr> <tr><td>12</td><td>13</td><td>14</td><td>15</td><td>16</td><td>17</td><td>18</td></tr> <tr><td>19</td><td>20</td><td>21</td><td>22</td><td>23</td><td>24</td><td>25</td></tr> <tr><td>26</td><td>27</td><td>28</td><td>29</td><td>30</td><td>31</td><td></td></tr> </tbody> </table>	Su	Mo	Tu	We	Th	Fr	Sa				1	2	3	4	5	6	7	8	9	10	11	12	13	14	15	16	17	18	19	20	21	22	23	24	25	26	27	28	29	30	31		<table border="1"> <thead> <tr> <th>Su</th><th>Mo</th><th>Tu</th><th>We</th><th>Th</th><th>Fr</th><th>Sa</th></tr> </thead> <tbody> <tr><td></td><td></td><td></td><td></td><td></td><td></td><td>1</td></tr> <tr><td>2</td><td>3</td><td>4</td><td>5</td><td>6</td><td>7</td><td>8</td></tr> <tr><td>9</td><td>10</td><td>11</td><td>12</td><td>13</td><td>14</td><td>15</td></tr> <tr><td>16</td><td>17</td><td>18</td><td>19</td><td>20</td><td>21</td><td>22</td></tr> <tr><td>23</td><td>24</td><td>25</td><td>26</td><td>27</td><td>28</td><td>29</td></tr> <tr><td>30</td><td>31</td><td></td><td></td><td></td><td></td><td></td></tr> </tbody> </table>	Su	Mo	Tu	We	Th	Fr	Sa							1	2	3	4	5	6	7	8	9	10	11	12	13	14	15	16	17	18	19	20	21	22	23	24	25	26	27	28	29	30	31						<table border="1"> <thead> <tr> <th>Su</th><th>Mo</th><th>Tu</th><th>We</th><th>Th</th><th>Fr</th><th>Sa</th></tr> </thead> <tbody> <tr><td>2</td><td>3</td><td>4</td><td>5</td><td>6</td><td>7</td><td>8</td></tr> <tr><td>9</td><td>10</td><td>11</td><td>12</td><td>13</td><td>14</td><td>15</td></tr> <tr><td>16</td><td>17</td><td>18</td><td>19</td><td>20</td><td>21</td><td>22</td></tr> <tr><td>23</td><td>24</td><td>25</td><td>26</td><td>27</td><td>28</td><td>29</td></tr> <tr><td>30</td><td>31</td><td></td><td></td><td></td><td></td><td></td></tr> </tbody> </table>	Su	Mo	Tu	We	Th	Fr	Sa	2	3	4	5	6	7	8	9	10	11	12	13	14	15	16	17	18	19	20	21	22	23	24	25	26	27	28	29	30	31						<table border="1"> <thead> <tr> <th>Su</th><th>Mo</th><th>Tu</th><th>We</th><th>Th</th><th>Fr</th><th>Sa</th></tr> </thead> <tbody> <tr><td></td><td></td><td></td><td>1</td><td>2</td><td>3</td><td>4</td></tr> <tr><td>5</td><td>6</td><td>7</td><td>8</td><td>9</td><td>10</td><td>11</td></tr> <tr><td>12</td><td>13</td><td>14</td><td>15</td><td>16</td><td>17</td><td>18</td></tr> <tr><td>19</td><td>20</td><td>21</td><td>22</td><td>23</td><td>24</td><td>25</td></tr> <tr><td>26</td><td>27</td><td>28</td><td>29</td><td>30</td><td></td><td></td></tr> </tbody> </table>	Su	Mo	Tu	We	Th	Fr	Sa				1	2	3	4	5	6	7	8	9	10	11	12	13	14	15	16	17	18	19	20	21	22	23	24	25	26	27	28	29	30			<table border="1"> <thead> <tr> <th>May 2014</th> <th>June 2014</th> <th>July 2014</th> </tr> </thead> <tbody> <tr> <td> <table border="1"> <thead> <tr> <th>Su</th><th>Mo</th><th>Tu</th><th>We</th><th>Th</th><th>Fr</th><th>Sa</th></tr> </thead> <tbody> <tr><td></td><td></td><td></td><td></td><td>1</td><td>2</td><td>3</td></tr> <tr><td>4</td><td>5</td><td>6</td><td>7</td><td>8</td><td>9</td><td>10</td></tr> <tr><td>11</td><td>12</td><td>13</td><td>14</td><td>15</td><td>16</td><td>17</td></tr> <tr><td>18</td><td>19</td><td>20</td><td>21</td><td>22</td><td>23</td><td>24</td></tr> <tr><td>25</td><td>26</td><td>27</td><td>28</td><td>29</td><td>30</td><td>31</td></tr> </tbody> </table> </td> <td> <table border="1"> <thead> <tr> <th>Su</th><th>Mo</th><th>Tu</th><th>We</th><th>Th</th><th>Fr</th><th>Sa</th></tr> </thead> <tbody> <tr><td>1</td><td>2</td><td>3</td><td>4</td><td>5</td><td>6</td><td>7</td></tr> <tr><td>8</td><td>9</td><td>10</td><td>11</td><td>12</td><td>13</td><td>14</td></tr> <tr><td>15</td><td>16</td><td>17</td><td>18</td><td>19</td><td>20</td><td>21</td></tr> <tr><td>22</td><td>23</td><td>24</td><td>25</td><td>26</td><td>27</td><td>28</td></tr> <tr><td>29</td><td>30</td><td></td><td></td><td></td><td></td><td></td></tr> </tbody> </table> </td> <td> <table border="1"> <thead> <tr> <th>Su</th><th>Mo</th><th>Tu</th><th>We</th><th>Th</th><th>Fr</th><th>Sa</th></tr> </thead> <tbody> <tr><td></td><td></td><td>1</td><td>2</td><td>3</td><td>4</td><td>5</td></tr> <tr><td>6</td><td>7</td><td>8</td><td>9</td><td>10</td><td>11</td><td>12</td></tr> <tr><td>13</td><td>14</td><td>15</td><td>16</td><td>17</td><td>18</td><td>19</td></tr> <tr><td>20</td><td>21</td><td>22</td><td>23</td><td>24</td><td>25</td><td>26</td></tr> <tr><td>27</td><td>28</td><td>29</td><td>30</td><td>31</td><td></td><td></td></tr> </tbody> </table> </td> </tr> </tbody> </table>	May 2014	June 2014	July 2014	<table border="1"> <thead> <tr> <th>Su</th><th>Mo</th><th>Tu</th><th>We</th><th>Th</th><th>Fr</th><th>Sa</th></tr> </thead> <tbody> <tr><td></td><td></td><td></td><td></td><td>1</td><td>2</td><td>3</td></tr> <tr><td>4</td><td>5</td><td>6</td><td>7</td><td>8</td><td>9</td><td>10</td></tr> <tr><td>11</td><td>12</td><td>13</td><td>14</td><td>15</td><td>16</td><td>17</td></tr> <tr><td>18</td><td>19</td><td>20</td><td>21</td><td>22</td><td>23</td><td>24</td></tr> <tr><td>25</td><td>26</td><td>27</td><td>28</td><td>29</td><td>30</td><td>31</td></tr> </tbody> </table>	Su	Mo	Tu	We	Th	Fr	Sa					1	2	3	4	5	6	7	8	9	10	11	12	13	14	15	16	17	18	19	20	21	22	23	24	25	26	27	28	29	30	31	<table border="1"> <thead> <tr> <th>Su</th><th>Mo</th><th>Tu</th><th>We</th><th>Th</th><th>Fr</th><th>Sa</th></tr> </thead> <tbody> <tr><td>1</td><td>2</td><td>3</td><td>4</td><td>5</td><td>6</td><td>7</td></tr> <tr><td>8</td><td>9</td><td>10</td><td>11</td><td>12</td><td>13</td><td>14</td></tr> <tr><td>15</td><td>16</td><td>17</td><td>18</td><td>19</td><td>20</td><td>21</td></tr> <tr><td>22</td><td>23</td><td>24</td><td>25</td><td>26</td><td>27</td><td>28</td></tr> <tr><td>29</td><td>30</td><td></td><td></td><td></td><td></td><td></td></tr> </tbody> </table>	Su	Mo	Tu	We	Th	Fr	Sa	1	2	3	4	5	6	7	8	9	10	11	12	13	14	15	16	17	18	19	20	21	22	23	24	25	26	27	28	29	30						<table border="1"> <thead> <tr> <th>Su</th><th>Mo</th><th>Tu</th><th>We</th><th>Th</th><th>Fr</th><th>Sa</th></tr> </thead> <tbody> <tr><td></td><td></td><td>1</td><td>2</td><td>3</td><td>4</td><td>5</td></tr> <tr><td>6</td><td>7</td><td>8</td><td>9</td><td>10</td><td>11</td><td>12</td></tr> <tr><td>13</td><td>14</td><td>15</td><td>16</td><td>17</td><td>18</td><td>19</td></tr> <tr><td>20</td><td>21</td><td>22</td><td>23</td><td>24</td><td>25</td><td>26</td></tr> <tr><td>27</td><td>28</td><td>29</td><td>30</td><td>31</td><td></td><td></td></tr> </tbody> </table>	Su	Mo	Tu	We	Th	Fr	Sa			1	2	3	4	5	6	7	8	9	10	11	12	13	14	15	16	17	18	19	20	21	22	23	24	25	26	27	28	29	30	31		
January 2014	February 2014	March 2014	April 2014																																																																																																																																																																																																																																																																																																																									
<table border="1"> <thead> <tr> <th>Su</th><th>Mo</th><th>Tu</th><th>We</th><th>Th</th><th>Fr</th><th>Sa</th></tr> </thead> <tbody> <tr><td></td><td></td><td></td><td>1</td><td>2</td><td>3</td><td>4</td></tr> <tr><td>5</td><td>6</td><td>7</td><td>8</td><td>9</td><td>10</td><td>11</td></tr> <tr><td>12</td><td>13</td><td>14</td><td>15</td><td>16</td><td>17</td><td>18</td></tr> <tr><td>19</td><td>20</td><td>21</td><td>22</td><td>23</td><td>24</td><td>25</td></tr> <tr><td>26</td><td>27</td><td>28</td><td>29</td><td>30</td><td>31</td><td></td></tr> </tbody> </table>	Su	Mo	Tu	We	Th	Fr	Sa				1	2	3	4	5	6	7	8	9	10	11	12	13	14	15	16	17	18	19	20	21	22	23	24	25	26	27	28	29	30	31		<table border="1"> <thead> <tr> <th>Su</th><th>Mo</th><th>Tu</th><th>We</th><th>Th</th><th>Fr</th><th>Sa</th></tr> </thead> <tbody> <tr><td></td><td></td><td></td><td></td><td></td><td></td><td>1</td></tr> <tr><td>2</td><td>3</td><td>4</td><td>5</td><td>6</td><td>7</td><td>8</td></tr> <tr><td>9</td><td>10</td><td>11</td><td>12</td><td>13</td><td>14</td><td>15</td></tr> <tr><td>16</td><td>17</td><td>18</td><td>19</td><td>20</td><td>21</td><td>22</td></tr> <tr><td>23</td><td>24</td><td>25</td><td>26</td><td>27</td><td>28</td><td>29</td></tr> <tr><td>30</td><td>31</td><td></td><td></td><td></td><td></td><td></td></tr> </tbody> </table>	Su	Mo	Tu	We	Th	Fr	Sa							1	2	3	4	5	6	7	8	9	10	11	12	13	14	15	16	17	18	19	20	21	22	23	24	25	26	27	28	29	30	31						<table border="1"> <thead> <tr> <th>Su</th><th>Mo</th><th>Tu</th><th>We</th><th>Th</th><th>Fr</th><th>Sa</th></tr> </thead> <tbody> <tr><td>2</td><td>3</td><td>4</td><td>5</td><td>6</td><td>7</td><td>8</td></tr> <tr><td>9</td><td>10</td><td>11</td><td>12</td><td>13</td><td>14</td><td>15</td></tr> <tr><td>16</td><td>17</td><td>18</td><td>19</td><td>20</td><td>21</td><td>22</td></tr> <tr><td>23</td><td>24</td><td>25</td><td>26</td><td>27</td><td>28</td><td>29</td></tr> <tr><td>30</td><td>31</td><td></td><td></td><td></td><td></td><td></td></tr> </tbody> </table>	Su	Mo	Tu	We	Th	Fr	Sa	2	3	4	5	6	7	8	9	10	11	12	13	14	15	16	17	18	19	20	21	22	23	24	25	26	27	28	29	30	31						<table border="1"> <thead> <tr> <th>Su</th><th>Mo</th><th>Tu</th><th>We</th><th>Th</th><th>Fr</th><th>Sa</th></tr> </thead> <tbody> <tr><td></td><td></td><td></td><td>1</td><td>2</td><td>3</td><td>4</td></tr> <tr><td>5</td><td>6</td><td>7</td><td>8</td><td>9</td><td>10</td><td>11</td></tr> <tr><td>12</td><td>13</td><td>14</td><td>15</td><td>16</td><td>17</td><td>18</td></tr> <tr><td>19</td><td>20</td><td>21</td><td>22</td><td>23</td><td>24</td><td>25</td></tr> <tr><td>26</td><td>27</td><td>28</td><td>29</td><td>30</td><td></td><td></td></tr> </tbody> </table>	Su	Mo	Tu	We	Th	Fr	Sa				1	2	3	4	5	6	7	8	9	10	11	12	13	14	15	16	17	18	19	20	21	22	23	24	25	26	27	28	29	30																																																																																																																																												
Su	Mo	Tu	We	Th	Fr	Sa																																																																																																																																																																																																																																																																																																																						
			1	2	3	4																																																																																																																																																																																																																																																																																																																						
5	6	7	8	9	10	11																																																																																																																																																																																																																																																																																																																						
12	13	14	15	16	17	18																																																																																																																																																																																																																																																																																																																						
19	20	21	22	23	24	25																																																																																																																																																																																																																																																																																																																						
26	27	28	29	30	31																																																																																																																																																																																																																																																																																																																							
Su	Mo	Tu	We	Th	Fr	Sa																																																																																																																																																																																																																																																																																																																						
						1																																																																																																																																																																																																																																																																																																																						
2	3	4	5	6	7	8																																																																																																																																																																																																																																																																																																																						
9	10	11	12	13	14	15																																																																																																																																																																																																																																																																																																																						
16	17	18	19	20	21	22																																																																																																																																																																																																																																																																																																																						
23	24	25	26	27	28	29																																																																																																																																																																																																																																																																																																																						
30	31																																																																																																																																																																																																																																																																																																																											
Su	Mo	Tu	We	Th	Fr	Sa																																																																																																																																																																																																																																																																																																																						
2	3	4	5	6	7	8																																																																																																																																																																																																																																																																																																																						
9	10	11	12	13	14	15																																																																																																																																																																																																																																																																																																																						
16	17	18	19	20	21	22																																																																																																																																																																																																																																																																																																																						
23	24	25	26	27	28	29																																																																																																																																																																																																																																																																																																																						
30	31																																																																																																																																																																																																																																																																																																																											
Su	Mo	Tu	We	Th	Fr	Sa																																																																																																																																																																																																																																																																																																																						
			1	2	3	4																																																																																																																																																																																																																																																																																																																						
5	6	7	8	9	10	11																																																																																																																																																																																																																																																																																																																						
12	13	14	15	16	17	18																																																																																																																																																																																																																																																																																																																						
19	20	21	22	23	24	25																																																																																																																																																																																																																																																																																																																						
26	27	28	29	30																																																																																																																																																																																																																																																																																																																								
<table border="1"> <thead> <tr> <th>May 2014</th> <th>June 2014</th> <th>July 2014</th> </tr> </thead> <tbody> <tr> <td> <table border="1"> <thead> <tr> <th>Su</th><th>Mo</th><th>Tu</th><th>We</th><th>Th</th><th>Fr</th><th>Sa</th></tr> </thead> <tbody> <tr><td></td><td></td><td></td><td></td><td>1</td><td>2</td><td>3</td></tr> <tr><td>4</td><td>5</td><td>6</td><td>7</td><td>8</td><td>9</td><td>10</td></tr> <tr><td>11</td><td>12</td><td>13</td><td>14</td><td>15</td><td>16</td><td>17</td></tr> <tr><td>18</td><td>19</td><td>20</td><td>21</td><td>22</td><td>23</td><td>24</td></tr> <tr><td>25</td><td>26</td><td>27</td><td>28</td><td>29</td><td>30</td><td>31</td></tr> </tbody> </table> </td> <td> <table border="1"> <thead> <tr> <th>Su</th><th>Mo</th><th>Tu</th><th>We</th><th>Th</th><th>Fr</th><th>Sa</th></tr> </thead> <tbody> <tr><td>1</td><td>2</td><td>3</td><td>4</td><td>5</td><td>6</td><td>7</td></tr> <tr><td>8</td><td>9</td><td>10</td><td>11</td><td>12</td><td>13</td><td>14</td></tr> <tr><td>15</td><td>16</td><td>17</td><td>18</td><td>19</td><td>20</td><td>21</td></tr> <tr><td>22</td><td>23</td><td>24</td><td>25</td><td>26</td><td>27</td><td>28</td></tr> <tr><td>29</td><td>30</td><td></td><td></td><td></td><td></td><td></td></tr> </tbody> </table> </td> <td> <table border="1"> <thead> <tr> <th>Su</th><th>Mo</th><th>Tu</th><th>We</th><th>Th</th><th>Fr</th><th>Sa</th></tr> </thead> <tbody> <tr><td></td><td></td><td>1</td><td>2</td><td>3</td><td>4</td><td>5</td></tr> <tr><td>6</td><td>7</td><td>8</td><td>9</td><td>10</td><td>11</td><td>12</td></tr> <tr><td>13</td><td>14</td><td>15</td><td>16</td><td>17</td><td>18</td><td>19</td></tr> <tr><td>20</td><td>21</td><td>22</td><td>23</td><td>24</td><td>25</td><td>26</td></tr> <tr><td>27</td><td>28</td><td>29</td><td>30</td><td>31</td><td></td><td></td></tr> </tbody> </table> </td> </tr> </tbody> </table>	May 2014	June 2014	July 2014	<table border="1"> <thead> <tr> <th>Su</th><th>Mo</th><th>Tu</th><th>We</th><th>Th</th><th>Fr</th><th>Sa</th></tr> </thead> <tbody> <tr><td></td><td></td><td></td><td></td><td>1</td><td>2</td><td>3</td></tr> <tr><td>4</td><td>5</td><td>6</td><td>7</td><td>8</td><td>9</td><td>10</td></tr> <tr><td>11</td><td>12</td><td>13</td><td>14</td><td>15</td><td>16</td><td>17</td></tr> <tr><td>18</td><td>19</td><td>20</td><td>21</td><td>22</td><td>23</td><td>24</td></tr> <tr><td>25</td><td>26</td><td>27</td><td>28</td><td>29</td><td>30</td><td>31</td></tr> </tbody> </table>	Su	Mo	Tu	We	Th	Fr	Sa					1	2	3	4	5	6	7	8	9	10	11	12	13	14	15	16	17	18	19	20	21	22	23	24	25	26	27	28	29	30	31	<table border="1"> <thead> <tr> <th>Su</th><th>Mo</th><th>Tu</th><th>We</th><th>Th</th><th>Fr</th><th>Sa</th></tr> </thead> <tbody> <tr><td>1</td><td>2</td><td>3</td><td>4</td><td>5</td><td>6</td><td>7</td></tr> <tr><td>8</td><td>9</td><td>10</td><td>11</td><td>12</td><td>13</td><td>14</td></tr> <tr><td>15</td><td>16</td><td>17</td><td>18</td><td>19</td><td>20</td><td>21</td></tr> <tr><td>22</td><td>23</td><td>24</td><td>25</td><td>26</td><td>27</td><td>28</td></tr> <tr><td>29</td><td>30</td><td></td><td></td><td></td><td></td><td></td></tr> </tbody> </table>	Su	Mo	Tu	We	Th	Fr	Sa	1	2	3	4	5	6	7	8	9	10	11	12	13	14	15	16	17	18	19	20	21	22	23	24	25	26	27	28	29	30						<table border="1"> <thead> <tr> <th>Su</th><th>Mo</th><th>Tu</th><th>We</th><th>Th</th><th>Fr</th><th>Sa</th></tr> </thead> <tbody> <tr><td></td><td></td><td>1</td><td>2</td><td>3</td><td>4</td><td>5</td></tr> <tr><td>6</td><td>7</td><td>8</td><td>9</td><td>10</td><td>11</td><td>12</td></tr> <tr><td>13</td><td>14</td><td>15</td><td>16</td><td>17</td><td>18</td><td>19</td></tr> <tr><td>20</td><td>21</td><td>22</td><td>23</td><td>24</td><td>25</td><td>26</td></tr> <tr><td>27</td><td>28</td><td>29</td><td>30</td><td>31</td><td></td><td></td></tr> </tbody> </table>	Su	Mo	Tu	We	Th	Fr	Sa			1	2	3	4	5	6	7	8	9	10	11	12	13	14	15	16	17	18	19	20	21	22	23	24	25	26	27	28	29	30	31																																																																																																																																																																																										
May 2014	June 2014	July 2014																																																																																																																																																																																																																																																																																																																										
<table border="1"> <thead> <tr> <th>Su</th><th>Mo</th><th>Tu</th><th>We</th><th>Th</th><th>Fr</th><th>Sa</th></tr> </thead> <tbody> <tr><td></td><td></td><td></td><td></td><td>1</td><td>2</td><td>3</td></tr> <tr><td>4</td><td>5</td><td>6</td><td>7</td><td>8</td><td>9</td><td>10</td></tr> <tr><td>11</td><td>12</td><td>13</td><td>14</td><td>15</td><td>16</td><td>17</td></tr> <tr><td>18</td><td>19</td><td>20</td><td>21</td><td>22</td><td>23</td><td>24</td></tr> <tr><td>25</td><td>26</td><td>27</td><td>28</td><td>29</td><td>30</td><td>31</td></tr> </tbody> </table>	Su	Mo	Tu	We	Th	Fr	Sa					1	2	3	4	5	6	7	8	9	10	11	12	13	14	15	16	17	18	19	20	21	22	23	24	25	26	27	28	29	30	31	<table border="1"> <thead> <tr> <th>Su</th><th>Mo</th><th>Tu</th><th>We</th><th>Th</th><th>Fr</th><th>Sa</th></tr> </thead> <tbody> <tr><td>1</td><td>2</td><td>3</td><td>4</td><td>5</td><td>6</td><td>7</td></tr> <tr><td>8</td><td>9</td><td>10</td><td>11</td><td>12</td><td>13</td><td>14</td></tr> <tr><td>15</td><td>16</td><td>17</td><td>18</td><td>19</td><td>20</td><td>21</td></tr> <tr><td>22</td><td>23</td><td>24</td><td>25</td><td>26</td><td>27</td><td>28</td></tr> <tr><td>29</td><td>30</td><td></td><td></td><td></td><td></td><td></td></tr> </tbody> </table>	Su	Mo	Tu	We	Th	Fr	Sa	1	2	3	4	5	6	7	8	9	10	11	12	13	14	15	16	17	18	19	20	21	22	23	24	25	26	27	28	29	30						<table border="1"> <thead> <tr> <th>Su</th><th>Mo</th><th>Tu</th><th>We</th><th>Th</th><th>Fr</th><th>Sa</th></tr> </thead> <tbody> <tr><td></td><td></td><td>1</td><td>2</td><td>3</td><td>4</td><td>5</td></tr> <tr><td>6</td><td>7</td><td>8</td><td>9</td><td>10</td><td>11</td><td>12</td></tr> <tr><td>13</td><td>14</td><td>15</td><td>16</td><td>17</td><td>18</td><td>19</td></tr> <tr><td>20</td><td>21</td><td>22</td><td>23</td><td>24</td><td>25</td><td>26</td></tr> <tr><td>27</td><td>28</td><td>29</td><td>30</td><td>31</td><td></td><td></td></tr> </tbody> </table>	Su	Mo	Tu	We	Th	Fr	Sa			1	2	3	4	5	6	7	8	9	10	11	12	13	14	15	16	17	18	19	20	21	22	23	24	25	26	27	28	29	30	31																																																																																																																																																																																														
Su	Mo	Tu	We	Th	Fr	Sa																																																																																																																																																																																																																																																																																																																						
				1	2	3																																																																																																																																																																																																																																																																																																																						
4	5	6	7	8	9	10																																																																																																																																																																																																																																																																																																																						
11	12	13	14	15	16	17																																																																																																																																																																																																																																																																																																																						
18	19	20	21	22	23	24																																																																																																																																																																																																																																																																																																																						
25	26	27	28	29	30	31																																																																																																																																																																																																																																																																																																																						
Su	Mo	Tu	We	Th	Fr	Sa																																																																																																																																																																																																																																																																																																																						
1	2	3	4	5	6	7																																																																																																																																																																																																																																																																																																																						
8	9	10	11	12	13	14																																																																																																																																																																																																																																																																																																																						
15	16	17	18	19	20	21																																																																																																																																																																																																																																																																																																																						
22	23	24	25	26	27	28																																																																																																																																																																																																																																																																																																																						
29	30																																																																																																																																																																																																																																																																																																																											
Su	Mo	Tu	We	Th	Fr	Sa																																																																																																																																																																																																																																																																																																																						
		1	2	3	4	5																																																																																																																																																																																																																																																																																																																						
6	7	8	9	10	11	12																																																																																																																																																																																																																																																																																																																						
13	14	15	16	17	18	19																																																																																																																																																																																																																																																																																																																						
20	21	22	23	24	25	26																																																																																																																																																																																																																																																																																																																						
27	28	29	30	31																																																																																																																																																																																																																																																																																																																								

**Shaded Dates:**  
**School Days**  
**Work Days/Make Up:**  
**(10)**  
**Holidays: (18)**  
**No School**  
**Total School Days:**  
**222**

# Special Education

## What's an IEP?



Based on the federal government, any student who requires special education services must have an individualized education plan (IEP) developed and followed. An IEP must be created specifically and individualized for 1 student. The US Department of

## What's a 504 Plan?



Students who do not qualify for special education, but still need accommodations to best participate in school based on mental or physical disabilities are often eligible for a 504 plan. Eliada follows 504 plans for any student admitted with one.

Eliada started tracking student educational plans half way through the 2010 – 2011 fiscal year. The Program Evaluation Manager went back and documented if an educational plan was in place for those who were admitted prior to tracking; therefore, there is a higher possibility of error when reporting the percentage of students with educational plans. It is anticipated that the graph below under represents the number of students with a special education classification. Educational plans were tracked for students receiving Day Treatment and PRTF services. Therapeutic Foster Care is excluded because students do not receive Eliada educational services through TFC. While Eliada does not complete special education testing, it does follow student IEP's should they come to Eliada with one.

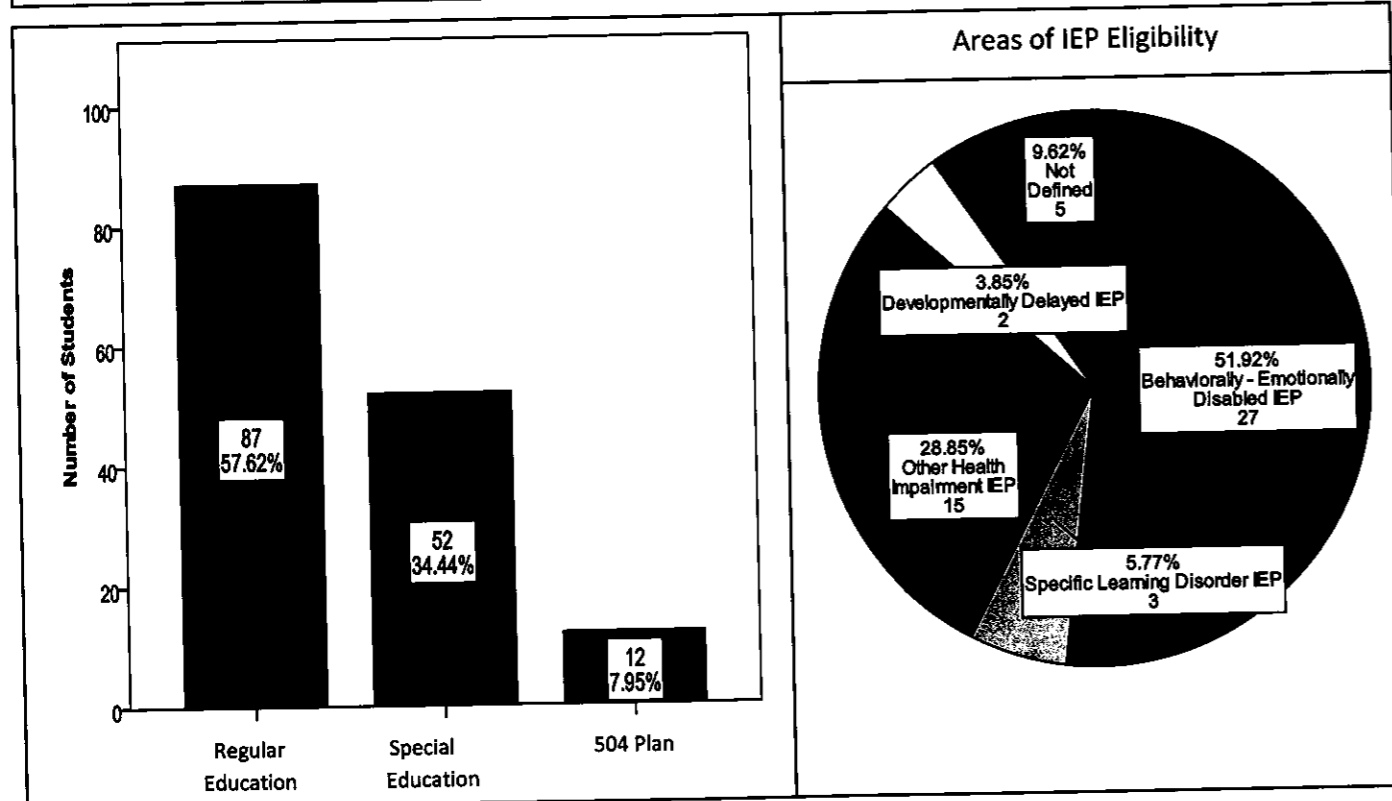

Out of 151 students, 64 students, or 42 percent, have either an IEP or a 504 plan. Currently, Eliada reports that 58 percent of students do not qualify for special education or classroom accommodations; however, with the new tracking procedure, this percentage is likely to decrease. There are certain areas of IEP eligibility. The pie graph represents percentages of IEP's that Eliada student's have and their area of eligibility. Out of the 52 students with IEP's, 22 students, or 42 percent, have a Behaviorally- Emotionally Disabled IEP. Other Health Impairment is the second most common type of IEP. The 10 percent of students with IEP's that are listed as "not defined" reflects a shortage of data. In this instance, paperwork documenting an IEP was identified; however, the specific type of IEP was not specified.

## Appendix: Assessment Timeline

ADMISSION

MIDPOINT

DISCHARGE

BASI

BASI

BASI

FORMATIVE  
ASSESSMENTS

BEHAVIOR  
INVENTORIES

BEHAVIOR  
INVENTORIES

STATE ASSESSMENTS  
IF TIMELY

STATE ASSESSMENTS  
IF TIMELY

# Title 1

Schools receive federal funding for education under the No Child Left Behind Act (2001). Title 1 is the largest federally funded education program. Through Title 1 qualification, congress provides supplemental school funds to districts/schools that have a high concentration of poverty. The amount funded by Title 1 is determined by the number of children who qualify. While Eliada is a treatment facility, it is also a Sothern Association of Colleges and Schools accredited school. Therefore, treatment programs with academic components, i.e. Day Treatment and PRTF, receive Title 1 funds. Out of the 158 students in those programs, 98% qualify for Title 1 funds.

“I am a custodian and a guardian of these kid’s academic skills. My job is to keep them sharp, keep them acclimated to the classroom, to not let their skills erode any further than they already have.”  
 ~ PRTF Teacher

## Qualify For Title 1

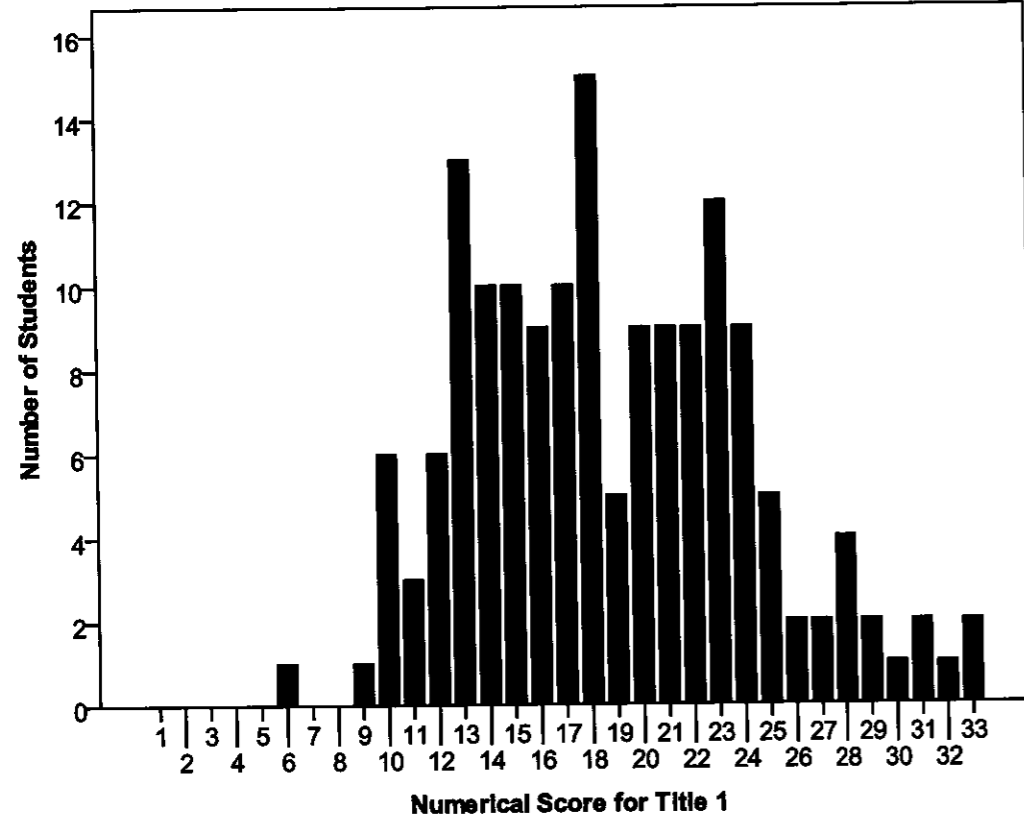

In order to qualify for Title 1 funds, students must score a 10 or above on the Title 1 Targeted Checklist. As noted above, 98% of student’s qualify for Title 1. Of those students, the average qualifying score is 19. Title 1 scores for Eliada PRTF and Day Treatment students range from 6 to 33. (Title 1 information comes from [www.ed.gov](http://www.ed.gov)).

## Appendix: EA Title 1 Targeted Checklist

Student Name: \_\_\_\_\_  
 Date Enrolled: \_\_\_\_\_

<b><i>Out of Home Placement</i></b>	
PRTF (4 points)	
Residential (3 points)	
Foster Care (2 points)	
Kinship (1 point)	
<b><i>Education Plan</i></b>	
Individual Education Plan (2 points)	
504 plan (1 point)	
<b><i>Assessment Results</i></b>	
Two or more grade levels below in both reading and math (4 points)	
Two or more grade levels in ONLY math or reading (3 points)	
Full scale IQ 80 – 85 (1 point)	
Full scale IQ 70 -79 (2 points)	
<b><i>Grade Level/Schooling</i></b>	
Retained at least once (1 point)	
Retained at least twice (2 points)	
Attended 3 or more schools (2 points)	
Missed 10 or more days in two or more school years. (2 points)	
<b><i>Mental Health</i></b>	
More than one Axis I diagnosis (3 points)	
Only one Axis I diagnosis (2 point)	
Victim of Physical and/or sexual abuse (2 points)	
Two or more visits/stays in a psychiatric hospital (2 points)	
Substance abuse history (2 points)	
<b><i>Consequences/Discipline</i></b>	
Suspended/Expelled from public school (3 points)	
Criminal charges (3 points)	

Total points \_\_\_\_\_

\*A student must have a minimum of 10 points to be targeted by Title 1 assistance.



## APPENDIX: BEHAVIOR MODEL SUMMARIES

**Reuter:** The Reuter Cottage behavior model is based primarily on fostering a Positive Peer Culture. Students are encouraged, and sometimes even required, to give and receive feedback and support to one another. During the day, students receive prompting cards for both negative and positive behaviors; accruing positive or negative cards can result in gain or loss of “choice time” or other appropriate natural consequences. Further, students can accrue cottage “tokens” for positive behaviors, which can be later exchanged for privilege items. Students in Reuter often call “groups,” where they can discuss situations and events as a cottage group to resolve any conflicts that may be going on. Otherwise, when students are not in the space to process situations with their peers, they may be removed from the group to process with a staff member. In situations of serious unsafe behaviors, students are temporarily removed from the group for extended processing of their behaviors. Students’ progress in treatment is measured by the cottage level system; students go up in their “levels” as they demonstrate mastery of prescribed treatment objectives, which leads to increasing access to various privileges. This primary model is supplemented with Skillstreaming and Aggression Replacement Therapy (ART).

**Lions:** The Lions Cottage behavior model is based primarily on helping students to recognize the cognitive flow of their behaviors. This model is based on three core components: validating the student’s feelings, reframing their actions/behaviors, and supporting the student in finding a healthy alternative behavior in the moment. During the day, students will receive prompts from staff for negative and positive behaviors. Negative behaviors may result in the loss of “choice time,” but students can earn back choice time for “re-doing” the behavior or otherwise exhibiting positive behaviors at another time. Further, students can accrue cottage “tokens” for positive behaviors, which can be later exchanged for privilege items. Students in Lions are usually asked to “take space” whenever they are struggling with a situation, at which time staff provide support for the student to process the event based on the cognitive behavior flow model. In situations of serious unsafe behaviors, students are temporarily removed from the group for extended processing of their behaviors. Students’ progress in treatment is measured by the cottage level system; students go up in their “levels” as they demonstrate mastery of prescribed treatment objectives, which leads to increasing access to various privileges. This primary model is supplemented with Skillstreaming and Aggression Replacement Therapy (ART).

**Reynolds:** The Reynolds Cottage behavior model is based primarily on Dialectical Behavior Therapy. Students are encouraged to think and act mindfully—operating in the present moment, free of judgment and open to all sides of a situation. The DBT model is taught to students through a series of in-cottage modules intended to develop students’ understanding of DBT and how to use it for their own personal growth and transformation. During the day, students are prompted for both negative and positive behaviors. Negative behaviors may result in the loss of “choice time,” but students may not gain back time for positive behaviors; this is intended to highlight the connection between behaviors and natural consequences. Students in Reynolds are usually asked to “take space” whenever they are struggling with a situation, at which time staff

provide support for the student to process the event based on the DBT model. In situations of serious unsafe behaviors, students are temporarily removed from the group for extended processing of their behaviors. Students' progress in treatment is measured by the cottage level system; students go up in their "levels" as they demonstrate mastery of prescribed treatment objectives, which leads to increasing access to various privileges. This primary model is supplemented with Skillstreaming and Aggression Replacement Therapy (ART).

**Day Treatment:** The behavior model employed in Day Treatment utilizes the *Skillstreaming*<sup>1</sup> approach and a level system to help children and adolescents learn skills and behaviors that will ensure their success in public school and in life. Skillstreaming employs a four-part training approach — modeling, role-playing, feedback, and generalization to teach these essential skills. Staff members model the expectations, have students practice the skills, provide feedback on their performance, and help students generalize the use of new behaviors beyond the controlled Day Treatment setting. The approach is adapted for elementary-aged children and for adolescents. Our level system utilizes the colors of the rainbow to indicate which level a student is on and their progression through the system. Students start with the most basic skills at the Red level, e.g. listening, raising your hand, and asking permission, and they work through the levels to learn respect, responsibility, honesty, fairness, trustworthiness, and integrity, ending at Indigo, at which point they are focusing on caring for self and others and on being good citizens.

**Cummings and Earle** These two cottages focus on each child's (younger children ages 6-11) personal and therapeutic goals within a structured, normalized, family-like setting. Each cottage has a comprehensive schedule and a defined set of rules and/or expectations that are designed to ensure safety at all times. Progression through the program is based solely on children's behavior. When children engage in positive and appropriate behavior, they work towards earning motivators. When children engage in negative behavior, they are re-directed and introduced to coping skills to help them meet their goals. Each cottage has their own unique behavior contract system to help each child on an individual basis. The behavior models are in place to help students recognize that behaviors have consequences whether it is negative or positive. As children advance through the motivation system their skills and treatment curriculum will grow and become more focused. Each week there will be an opportunity to earn advancement badges through the motivation system.

---

<sup>1</sup> <http://www.skillstreaming.com/>

Approved by the Board of Trustees: 10/31/94

Revision Approved by the Board of Trustees: 3/20/00

**POLICY:** It is the policy of Eliada Homes, Inc. (EHI) that staff/foster parents will employ fair and consistent behavior management practices which respect and maintain the basic dignity of all clients. No philosophies or practices will be employed which encourage or promote humiliation, degradation, verbal abuse, intimidation, physical abuse, the threat or infliction of pain, or the denial of basic client rights.

**PROCEDURE:**

- (1) Assessment during intake and admissions includes evaluation of the potential risk of harm to self or others and determination of behavior and crisis management plans.
- (2) Behavior management techniques taught in Therapeutic Crisis Intervention and program specific pre-service and in-service training will be utilized by staff/foster parents in their supervision of and interactions with clients. Examples of appropriate behavior management techniques include, but are not limited to:
  - a) Structuring the environment
  - b) Planned ignoring
  - c) Hypodermic affection
  - d) Hurdle help
  - e) Non-verbal interventions
  - f) Redirecting
  - g) Directive statements
  - h) Time-outs
  - i) Prompts
  - j) Observation/monitoring behavior
  - k) Reinforcement
  - l) Preventive, positive, corrective and intensive teachings.
  - m) Discuss and process
  - n) Modeling
- (3) Staff/foster parents will always attempt to utilize the least restrictive technique possible in each situation.
- (4) Staff/foster parents in FPP, TFC, FC should report immediately for supervision when clients are demonstrating out of control behaviors. If there is immediate danger,

staff/foster parents/families should immediately call law enforcement for assistance.

(5) The following procedures are prohibited:

- a) Corporal punishment techniques of any kind.
- b) Mechanical restraint procedures (defined as the restraint of a client with the intent of controlling behavior with mechanical devices which include, but are not limited to, cuffs, ankle straps, sheets or restraining shirts).
- c) Denial of regularly scheduled meals or snacks for behavior management.
- d) Administration of medication for behavior management (unless authorized by custodian and physician).
- e) Administration of disciplinary measures to clients when such measures are not warranted.
- f) Administration of punitive work assignments to clients (i.e., work assignments which are not a natural and logical consequence of the client's behavior).
- g) Denial of regularly scheduled visits with family or other custodian approved visiting resources for behavior management (unless authorized by custodian).
- h) Removal of doors on bedrooms and bathrooms, unless there is a clear, clinical justification for their removal.
- i) Forced physical exercise solely for the purpose of eliminating behavior.
- j) Forced tasting of unpleasant foodstuffs.
- k) Contingent application of any noxious substances which include, but are not limited to, noise, bad smells, or splashing with water.
- l) Contingent use of painful body contact.
- m) Electric shock (excluding medically administered electroconvulsive therapy);
- n) Insulin shock
- o) Punishment by peers
- p) Group punishment or discipline for individual behaviors

(6) The following procedures shall only be employed when clinically or medically indicated as a method of therapeutic treatment:

- a) planned non-attention to specific undesirable behaviors when those behaviors are health threatening;
- b) contingent deprivation of any basic necessity; or
- c) other professionally acceptable behavior modification procedures that are not prohibited by rule.

(7) The following procedure is prohibited in all programs except Psychiatric Residential

Treatment Facility (PRTF):

- a) Seclusion, which is the isolation of a client in a separate locked room for the purpose of controlling behavior.
- (8) An intervention is discontinued immediately if it produces adverse side effects or is deemed unacceptable according to prevailing professional standards.

Approved by the Board of Trustees: 10/31/94

Revision Approved by the Board of Trustees: 3/20/00

**POLICY:** It is the policy of Eliada Homes, Inc, (EHI) that staff will at all times respect the rights of clients as individuals. If at any time a client wishes to express dissatisfaction with services received, or feels that his/her rights have been violated, he/she may make a formal grievance. All clients/custodians will be made aware of the Client Grievance policy upon admission to an EHI program with documentation of such maintained in the client record.

**PROCEDURE:**

- (1) The client presents grievance to the case manager. The case manager will:
  - a) Acknowledge to the client in writing that the grievance has been received,
  - b) Present the client with a copy of the current Client Grievance policy,
  - c) Meet with the client to discuss and, hopefully, resolve the problem,
  - d) Respond to the client with a written decision within 5 days of this meeting,
  - e) File the grievance in a separate file entitled Client Grievances, not in the client record and,
  - f) Forward copies of the grievance and all subsequent correspondence related to the grievance to program administration and Continuous Quality Improvement (CQI).
  - g) If for any reason, a client cannot write, a grievance may be made verbally or written for the client.
- (2) If after taking this action, the client does not feel that the problem has been resolved, he/she may submit the grievance to program administration. Within 5 days from receipt of the grievance, program administration will:
  - a) Respond to the client with a written decision and
  - b) Forward additional copies of the response to the case manager (for entry into the Client Grievances file) and to CQI.
  - c) Notify the custodian and contracting agency.
- (3) If the decision is still not satisfactory to the client, a final appeal may be made to the Chief Operations Officer of EHI. The Chief Operations Officer's decision will be final. Within 15 days from receipt of the grievance, the Chief Operations Officer will respond to the client with a written decision. Additional copies of this response will be forwarded to program administration, the case manager (for entry into the Client Grievances file) and CQI.

- (4) The client will, at this point, direct any further appeal of the issue to their custodian/contracting agency.
- (5) An annual summary of grievances will be reviewed by EHI's President/CEO and Board of Trustees.
- (6) All grievances will be reviewed on a quarterly basis by the agency's Client Rights committee. Their findings/recommendations will be distributed to program administration and the appropriate CQI team for follow up or corrective action.

Approved by the Board of Trustees: 10/31/94

Revision Approved by the Board of Trustees: 1/21/02

**POLICY:** It is the policy of Eliada Homes, Inc. (EHI) that restrictive interventions will only be used as defined in the current state and federal licensing rules, federal Medicaid rules and national accreditation standards. Restrictive interventions will not be used as punishment, retaliation, for the convenience of staff, to cover inadequate staffing, or will not be used in a manner which causes undue harm, physical/mental discomfort, or pain to the client. They will be administered only after all less restrictive interventions have proven to be ineffective. The agency will only use models approved by the State of North Carolina, including the training and documentation requirements described in the state rules, in situations requiring a restrictive intervention.

**PROCEDURE:**

I. DEFINITIONS:

- a) "Restrictive intervention" means an intervention procedure which presents a significant risk of mental or physical harm to the client and; therefore, requires additional safeguards.
- b) "Physical restraint" means the application or use of any manual method of restraint that restricts freedom of movement; or the application or use of any physical technique that restricts freedom of movement or normal access to one's body. Holding a client in a therapeutic hold or other manner that restricts his or her movement constitutes manual restraint for the client. Excluded from this definition of physical restraint are physical guidance, gentle physical prompting techniques, and removing a client who is walking.
- c) "Seclusion" means the isolating of a client in a separate locked room for the purpose of controlling a client's behavior.



- d) "Unplanned intervention" is the emergency use of restrictive interventions that is not part of the client's service plan, but must be used to terminate a behavior or action in which the client is in imminent danger of abuse or injury to self/others or when substantial property damage involving imminent danger to the client or others is occurring.
- e) "Planned intervention" is the planned use of restrictive interventions as a measure of therapeutic treatment designed to reduce dangerous, aggressive, self-injurious, or undesirable behaviors to a level which will allow the use of less restrictive treatment procedures.

## II. PARAMETERS OF RESTRICTIVE INTERVENTION

- a) Physical restraint, isolation time out, and seclusion are the only restrictive interventions allowed at Eliada Homes, Inc.
- b) Seclusion is allowed only in the PRTF. PRTF seclusion rooms must meet existing licensure standards, and are limited to one client at a time.
- c) Physical restraints are allowed in the following programs only:
  - PRTF (Psychiatric Residential Treatment Facility)
  - Day Treatment
- d) Simultaneous use of physical restraint and seclusion are prohibited in the PRTF.
- e) Restrictive interventions are not permitted in Family Foster Care or Therapeutic Foster Care programs.
- f) Restrictive interventions will be initiated and implemented by staff only. Clients may not restrain other clients.
- g) Written informed consent for the use of restrictive interventions will be obtained from the client's custodian upon admission to an EHI program.
- h) During the intake/admission process, each client is assessed by review of placement history, intake documentation, nurse's evaluation, and psychiatric evaluation for the

potential need for restrictive interventions. Assessment includes antecedents to harassing, violent or out of control behavior; previous use of restrictive interventions; and psychological and social factors. Planned use of restrictive intervention must be written in the client's service plan and signed by the client's custodian. This, however, does not constitute a "standing order" for the use of restrictive intervention with PRTF clients.

- i) Physician approval and periodic monitoring will be obtained for use of physical restraints with clients having a reasonably foreseeable physical consequence to the use of physical restraint. The client's current physical examination or psychiatric evaluation must identify if there are any pre-existing medical conditions, disabilities, or limitations that would place the client at greater risk during use of physical restraint.

- 1) The physician will document the restriction on use of restrictive intervention in the client's medical record;
- 2) The case manager will develop a crisis plan identifying alternative emergency procedures, if needed, and will ensure that all staff are aware of both the restriction from the use of physical restraint and the alternative intervention plan.

- j) Restrictive intervention may not be used in excess of 2 continuous hours for children 9 to 17 years old and 1 hour for children less than 9 years old. However, National Accreditation standards state the following time limits for restrictive interventions:

Restraint

15 minutes for 9 years and younger; 30 minutes for children 10 and older

Seclusion

15 minutes for 9 years and younger; 30 minutes for 10-13 years; 1 hour for children 14 and older

Isolation time out

15 minutes for 9 years and younger; 30 minutes for 10-13 years; 1 hour for children 14 and older

On a case by case basis, physical restraint time frames may be extended for chronic self harming behaviors with approval from an authorized Qualified Professional.

Seclusion time frames may be extended for chronic, self harming behaviors, when approved by a physician, nurse practitioner, or physician's assistant.

- k) A licensed psychiatrist, during weekly medication evaluations in PRTF will review any seclusion exceeding 30 minutes. If concerns are noted, they will be discussed at the weekly multidisciplinary meeting.
- l) The use of restrictive interventions will be discontinued as soon as therapeutically appropriate, but no more than 30 minutes, after the client gains behavioral control.

### III. MONITORING OF RESTRICTIVE INTERVENTION

- a) Restraint and seclusion must be monitored by a licensed nurse in PRTF. Restraints and isolation time out in Day Treatment must be continuously monitored by a staff member.
- b) Nurse/Staff must conduct a health status check prior to, continuously throughout, and for a minimum of 30 minutes after completion of the restrictive intervention. During and following a restraint, a nurse/staff member must monitor the client's breathing, verbal responsiveness, and motor control, and ensure that the client remains conscious without any complaints of pain. If the client complains of being unable to breathe or loses motor control, nurse/staff will terminate the restraint or will adjust the position to ensure that the client's breathing and motor control are not restricted. If at any time the client appears to be in distress, nurse/staff will provide and/or seek medical attention for the client.
- c) During and following a seclusion a nurse must monitor the client's breathing, verbal responsiveness, motor control, and ensure that the client remains conscious. A health status check on the client will occur before and after a seclusion has occurred.
- d) For PRTF clients, a clinical staff trained in the use of emergency safety interventions must be physically present, continually assessing and monitoring the physical and psychological well-being of the resident and the safe use of restraint throughout the duration of the emergency safety intervention.

- e) Nurse/Staff must monitor the client's need for food, water, and use of bathroom facilities throughout the restrictive intervention and will provide access when safe and appropriate.
- f) For PRTF clients, within one hour of the initiation of the emergency safety intervention a physician, or licensed practitioner trained in the use of emergency safety interventions and permitted by the State and facility to assess the physical and psychological well being of residents, must conduct a face-to-face assessment of the physical and psychological well being of the resident. The client's well-being must also be evaluated following the conclusion of the restraint or seclusion.
- g) For PRTF clients, the physician or other licensed practitioner permitted by the State and the facility to order restraint or seclusion must be available to staff for consultation, at least by telephone, throughout the period of the emergency safety intervention.

#### IV. AUTHORIZATION OF RESTRICTIVE INTERVENTION

- a) The Registered Nurse (responsible professional) on site will authorize restrictive intervention initially. The Registered Nurse will immediately call the Physician Assistant/MD on call to obtain a verbal order for use of restrictive intervention per federal standards. The nurse present in the facility will complete a ***Restrictive Intervention Order Form and Evaluation.***
- b) For PRTF clients, orders for restraint or seclusion must be made by a physician, or other licensed practitioner permitted by the State and facility to order restraint or seclusion and trained in the use of emergency safety interventions. Verbal orders for restraint or seclusion must be received by a Registered Nurse while the emergency safety intervention is being initiated by staff or immediately after the emergency safety situation ends.
- c) If the initial time limit on the order for restraint or seclusion should expire, then the Registered Nurse must immediately contact the person who originally ordered the safety intervention to receive further instructions.

## V. PLANNED USE OF RESTRICTIVE INTERVENTION

- a) Whenever restrictive interventions are administered to a client in a single episode of 24 continuous hours, more than 4 times in 30 consecutive days, or as a measure of therapeutic treatment, a planned intervention must be developed and written into the client's service plan. The case manager will obtain verbal consent from the client's custodian with written approval of the Child and Family Team at the next meeting. Orders for restraint and seclusion cannot be written as standing orders or on an as needed basis.
- b) Approval of the planned use of restrictive interventions will include notification of a client advocate.
- c) Physician approval must be obtained when the plan includes a specific intervention with reasonably foreseeable physical consequences. In such cases, periodic monitoring by a physician will be included in the plan. The ordering physician or licensed practitioner must contact the client's treatment physician as soon as possible following the emergency safety intervention to inform them of the reasons for the intervention. Those reasons must be documented in the client's record and the time when the physician was contacted must also be documented.
- d) Documentation in the client record regarding the planned use of restrictive interventions will include weekly evaluation by staff, Qualified Professional, and Licensed Clinician during clinical supervision.
- e) The Intervention Advisory Committee will have the opportunity to review the service plan and to recommend approval or disapproval of the planned use of restrictive interventions. Members of the Intervention Advisory Committee (IAC) will receive specific training and orientation as to the charge of the committee. They will be provided with copies of appropriate statutes and rules governing client rights and related issues. They will be provided, when available, copies of literature about the use of a proposed intervention and any alternatives to it. Minutes of the committee will be maintained for each meeting.
- f) Approval for the planned use of restrictive intervention is valid for no more than 6 months. Continuation must be based on behavioral evidence that the intervention is necessary and is having a positive impact.

## VI. TRAINING/ PRIVILEGING

- a) Staff must be trained in the appropriate uses of restraint, seclusion and isolation time out procedures prior to their use with clients.
- b) Staff must complete the crisis intervention curriculum and pass written and practical examinations before being privileged to administer physical restraints. Staff must on a semi-annual basis demonstrate competencies in the following:
  1. techniques to identify staff and client behavior that may trigger emergency safety situations.
  2. the use of non-physical interventions to prevent emergency safety situations
  3. the safe use of restraint, seclusion, and time out.Staff must be trained and certified in cardiopulmonary resuscitation, CPR, on an annual basis to administer physical restraint. Documentation of training will be maintained in personnel files.
- c) Trainers must successfully complete the crisis intervention train-the-trainer curriculum, and all refresher instructor courses, as specified by the approved curriculum.
- d) Day Treatment employees privileged to administer restrictive interventions are considered responsible professionals and are authorized to administer restrictive interventions for up to 15 minutes and to continuously assess the client throughout and after the restrictive intervention.

## VII. DOCUMENTATION/ FOLLOW THROUGH

- a) The use of restrictive intervention must be reported immediately to the Qualified Professional on call.
- b) A life space interview must be attempted or conducted with the client after a restrictive intervention. Debriefing must occur with the staff who administered the restrictive intervention and will include assessment of their physical and emotional status; precipitating events; how the incident was managed; and changes to avoid future incidents.
- c) Whenever restrictive intervention procedures are administered to a client, the custodian and others as pertinent to the case (family, Mental Health) will be

notified by staff as soon as possible, but no more than 24 hours after the incident. Verification of this notification will be recorded on the incident report. Debriefing must occur with the custodian.

- d) Level 2 incident reports will be entered into the IRIS system within 72 hours.
- e) Restrictive Intervention incident reports must be reviewed by the Qualified Professional/Supervisor within 48 hours after use of restrictive intervention and prior to distributing the reports. The professional/supervisor is responsible for assuring appropriate follow through and debriefing with the client, staff, and the client's custodian.
- f) Restrictive Intervention incident reports and logs will be reviewed by the Intervention Advisory committee at their quarterly meetings. This committee will include professionals who are not directly involved in the treatment of the clients and who have training and expertise in the use of restrictive interventions. The Intervention Advisory Committee will make an annual report of its activities and the use of restrictive interventions to Eliada Homes, Inc.'s Board of Trustees.

Approved by the Board of Trustees: 10/31/94

Revision Approved by the Board of Trustees: 3/20/00

---

**POLICY:** It is the policy of Eliada Homes, Inc. (EHI) that when there is reasonable cause to suspect that a client has contraband on their person or within the program, staff/foster parent will conduct a search of the client and/or premises in accordance with state licensing/accreditation guidelines. All clients/custodians will be informed of the Search and Seizure policy upon admission to an EHI program with documentation of such maintained in the client record.

**PROCEDURE:**

- (1) Staff/foster parents will inventory the client's possessions upon admission to a residential program or foster care home. All items brought to the program will be recorded in the inventory record and signed by the staff/foster parent and client. The inventory record will be maintained in the client record.
- (2) Staff/foster parents may search a client and their possessions when they are returning to the program from an off-campus visit or after receiving visitors when it is reasonable to believe the client may have items in their possession that are dangerous, illegal, or otherwise prohibited in the program.
- (3) Staff/foster parents may search a client, their possessions or their living area if there is cause to believe the client has been drinking or using drugs and may have contraband articles or substances in their possession. Situations justifying such a search may include, but are not limited to, the following:
  - a) Drinking, drug abuse, or possession of contraband articles or substances have been witnessed by staff/foster parent or reported by another client or other reliable informant;
  - b) When inappropriate changes in behavior are observed or reported, such as slurred speech, ataxia, odor of alcohol, or disruptive behaviors (excluding expected changes due to prescribed psychotropic medication);
  - c) When a stolen item has been witnessed by staff/foster parent, reported by another client or other reliable informant, or is clearly indicated by surrounding circumstances.
- (4) Searches by staff may include facility buildings and grounds.



- (5) Any search which would require touching the client is to be done by law personnel or the custodian. Authorization to request law enforcement to search the client must be received from the custodian prior to the search.
- (6) All searches must be authorized verbally by program administration except when staff/foster parents have a reasonable suspicion that a client has in his/her possession weapon or instrument making them presently dangerous, and this danger is imminent as to render prior authorization impracticable. Such searches will be implemented immediately.
- (7) Objects which may be harmful to clients or others may be confiscated by staff/foster parents without notice.
- (8) All searches will be documented and maintained on file. Documentation will include:
  - (a) the reason for the search;
  - (b) the scope of the search;
  - (c) the search procedure followed;
  - (d) a description of any property seized;
  - (e) an account of the disposition of the seized property;
  - (f) date, time, and location;
  - (g) signature of staff/foster parent.
- (9) If personal property is seized in a search, staff/foster parents will assess the situation and determine appropriate action, including discharge. The local law enforcement agency or juvenile court may be helpful for advice regarding appropriate disposition of property. The client's custodian will be notified of the search and its outcome.
- (10) If the results of a search support the suspicion of a client "dealing" (distribution) prohibited items, legal authorities will be notified.
- (11) Eliada Homes, Inc. reserves the right to take such further action as it deems appropriate in order to keep its clients, staff/foster parents, and visitors safe at all times.
- (12) This policy/procedure does not apply to the following programs:

Community Support/Case Management

# **Eliada Academy**

## Student Handbook



Individualized, Compassionate, Effective Treatment

# **School Year 2011-2012**

## **Table of Contents**

### **I. Eliada Homes, Inc. Mission and Vision Statement**

### **II. Expectations and Rules**

- Expectations
- General Rules
- Classroom Rules

### **III. Academy Procedures**

- Search and Seizure
- Binders
- Transitions
- PM Line-up
- Attendance/ Tardy Policy
- Grading
- Credits
- Homework
- Dress Code
- Backpacks and Book Bags
- Cafeteria
- Silent Lunch
- Inclement Weather Information
- Fire and Weather Drills
- Therapy and Treatment Group Expectations

### **IV. Eliada Homes Enhanced Services**

- TASC (Therapeutic Animal Stewardship Cooperative)
- NYPUM (National Youth Program Using Minibikes)
- Driving Range and Golf Shed
- Climbing Wall
- Weight Training
- Eliada Pool
- Gym
- Chapel
- Outdoor Activities

### **V. 10 Basic Skills**

**I. Eliada Homes, Inc.  
Mission and Vision Statement**



Mission  
Helping Children Succeed:

*Creating an optimal learning environment that empowers children and families to succeed*

Vision

To provide an optimal learning environment that empowers children and their families to succeed.

*Eliada Academy provides an optimal learning environment that promotes students' academic and behavioral success in and beyond Eliada Academy. Eliada Academy provides students with options and opportunities to be productive and active members of society.*

## II. EXPECTATIONS and RULES

### Respect Yourself, Others and Property

### Be Responsible

### GENERAL RULES

In order to maximize learning and ensure the safety of all students and staff, students are expected to comply with the following rules:

1. Students are expected to follow all classroom rules..
2. Students are not to write on their bodies or to make extra markings on their balance sheet.
3. Students are expected to follow the student dress code.
4. Students are expected eat the food that is offered in the cafeteria.
5. Students take their balance sheet home each day have a parent sign it and return it the next day.
6. Leaving the classroom or school building without permission will result in disciplinary action.
7. Students are expected to refrain from the use of physical or verbal aggression. If a student physically assaults a peer or staff, or damages property, disciplinary action will result and possible criminal charges will be filed.

#### ***TOBACCO USE***

Eliada Academy has a policy that absolutely no tobacco use may occur on the campus regardless of age or parental consent. This policy is directly related to our commitment to insuring your safety, health, and well-being. This policy extends to any person who comes onto Eliada Homes' campus.

#### ***ILLEGAL DRUG USE***

There is absolutely no "un-prescribed" or illegal drug use allowed on this campus. If you are found to be in possession of any illegal or "un-prescribed" substance, the police will be notified and charges will be pressed. If you have anything on your person now, turn it in. If you plan to acquire any during your stay here at Eliada, then think twice because the consequences will not only be within this program, but there will be legal consequences as well.

#### ***DATING BEHAVIOR***

You are here at Eliada Academy in order to focus on yourself and your treatment goals, not on your love life. It has been our experience that when one is consumed with the excitement and pain that can accompany any relationship, one is often distracted from focusing on what needs to be dealt with. Therefore we have a "No Dating Behavior" rule at Eliada Academy. During your stay, one of the goals of the staff at Eliada is to assist you in the development of positive and appropriate relationships with both genders of peers. We have established this rule so that you have the opportunity to focus on all of your treatment goals, as well as the development of positive peer relationships, without the distractions that a boyfriend/girlfriend can cause. "Dating Behavior" can include a lot of things so the staff in any classroom can inform you of the specifics.

#### ***RUNNING BEHAVIOR***

While you are in our care while at Eliada Academy, we are responsible for your safety and well-being. If you should choose to run away from the campus, or even run around on the campus, your safety is compromised. Therefore, if you choose to run from this facility our policy is to notify the Asheville Police Department and your family. If you leave campus, the police will have to pick you up and return you here. In addition to the possible legal and family consequences, there will also be a significant consequence in Day Treatment.

# Eliada Day Treatment Behavior Model

## June 2011

Students in Day Treatment will work on their personal treatment goals and learning responsibility using the behavior modification model developed by the staff of Eliada Academy. The purpose of the model is to assist students in learning and practicing social and behavioral skills that will help them become successful in school, their communities, and their home lives. Students will have the opportunity to complete a number of learning packets and activities associated with each skill. As they master the skills, they will progress up the Three Levels and Seven Steps (Red, Orange, Yellow, Blue, Green, Indigo, Violet) toward successful completion of treatment. They will leave our program with a portfolio of activities and resources that will help them in their next educational setting.

Every day, the students will have the chance to practice their skills and change behavior patterns and habits and these practice opportunities will be recorded on a balance sheet. Students take the balance sheet home in the afternoon, review it with their guardian(s), the guardians sign it and the student brings the balance sheet back to The Academy. Returning the balance sheet, signed and complete will earn the student a positive dollar amount on the balance sheet. If they forget to bring the balance sheet back or it isn't signed by a guardian, they receive a fine for responsibility. A summary of the model and copy of the balance sheet follows below.

### SUCCESSFUL COMPLETION OF TREATMENT

Violet Citizenship



Indigo: Caring for Self and Others



Level Three



Blue: DBT Skills



Green: Trustworthiness



Level Two



Yellow: Honesty and Fairness



Orange: Respect and Responsibility



## Red: Basic Skills and Self Awareness



### Level One

#### Balance Sheet Procedures

The **Purpose** of the Balance Sheet is to provide the students with an opportunity to track their behaviors, abilities to change those behaviors and to see a chain of cause and effect of those behaviors and choices. Additionally, the document provides daily feedback to students and information to parents and guardians and can be reviewed by the CFT for progress and continuing symptoms for students. Day Treatment also used the data to inform treatment and devise strategies to further assist students in their quest for success. Students on levels One and Two receive a balance sheet at the beginning of each day when they return their signed balance sheet from the previous day.

Students record positives and consequences on the balance sheet and keep a running total of the dollar value each day for each block of class

Staff teach to behaviors small and large (positively and with consequence)

Target behaviors earn \$1.00

Non-Target behaviors earn \$.50

No Balance sheet = \$10 fine

Balance sheet returned but not signed = \$5 fine

No binder/folder = \$1.50 (responsibility fine)

No uniform = \$5 fine first time, \$10 fine thereafter

Sagging = \$5 fine first time, \$10 fine thereafter

Secretive behavior = \$5

Pen charge = \$10 to rent a pen (you get \$6 back if you return the pen the same day you borrowed it)

No H/W = \$1.50 fine first day, increasing by .50 every day up to \$5 (per event)

Weekly attendance = \$1.50 award; daily attendance = .50 award

Lunchtime Etiquette = \$1.00/day (DINING DOLLARS)

Practices, if successfully completed on the same day, earn back ½ value. If completed the next school day, earn only .25

See ongoing procedures for consequence structure

#### Students must:

- Write legibly
- Complete the entire balance sheet front and back
- List behaviors for each positive or consequence
- Compute their balances correctly (staff will check math computations each block and at the beginning and end of each day)
- Record the number of Positives and Consequences each day

#### Balance sheet procedures

- Staff will review balance sheets to make sure that the top and back are filled out completely
- Staff will sign each behavior, practice and ongoing during each block
- Balances carry over daily for one week
- At the beginning of each week, balances all reset to ("0") zero.
- On Monday mornings, balances will be recorded and banked for purchases of school store items and motivators.
- Balance sheets will be collected and filed by student and stored in a file cabinet drawer

### Example of a Balance Sheet

LEVEL ONE BALANCE SHEET/Step Color RED, ORANGE, YELLOW (circle)

Name: \_\_\_\_\_ Date: \_\_\_\_\_ Day: \_\_\_\_\_

Target#1: \_\_\_\_\_ Target#2: \_\_\_\_\_ Balance: \_\_\_\_\_

Consequence (after 1<sup>st</sup>, becomes an Ongoing) Values: 1st: Earn -\$0.50\* 2nd: Earn -\$1\* 3rd: Earn -\$2\* 4th: Earn -\$3 5th: Earn -\$5  
 "O" indicates an Ongoing Process; "P" indicates a Practice/earn back 1/2 value of Consequence with a Practice

Class Name	Behavior	+Positives (add)	-Consequences (subtract)	Balance	Staff Initials/ O or P
EX. Math Math	Accepting Decisions of Authority	1.00			JT
	Not Accepting Consequences		.50	.50	JT
	Not Accepting Consequences		1.00	-.50	JT/O
	Deduct School Store Purchases				
+s	<b>TOTAL DOLLARS</b>				
-s	<b>TOTAL POINTS (WEEKLY)</b>				



(BACK)

Academy Target: \_\_\_\_\_

1. \_\_\_\_\_

2. \_\_\_\_\_

3. \_\_\_\_\_

4. \_\_\_\_\_

5. \_\_\_\_\_

Personal Target #1 : \_\_\_\_\_

1. \_\_\_\_\_

2. \_\_\_\_\_

3. \_\_\_\_\_

4. \_\_\_\_\_

5. \_\_\_\_\_

Personal Target: #2 \_\_\_\_\_

1. \_\_\_\_\_

2. \_\_\_\_\_

3. \_\_\_\_\_

4. \_\_\_\_\_

5. \_\_\_\_\_

**Safety Violations:**

Aggression toward Persons or Animals

Destruction of Property

Forging, Stealing or Cheating

Aggressively Moving Furniture  
Leaving the group or building without permission  
Fighting/Bullying  
Boundary Violations  
Excessive Truancy  
Illegal activities of any kind  
    Bring contraband or drugs to school  
    Bringing a weapon to school

May result in student appearing before Safety Council

**Guardian Signature:** \_\_\_\_\_ **Date:** \_\_\_\_\_

Personal Goal for the Week:

---

---

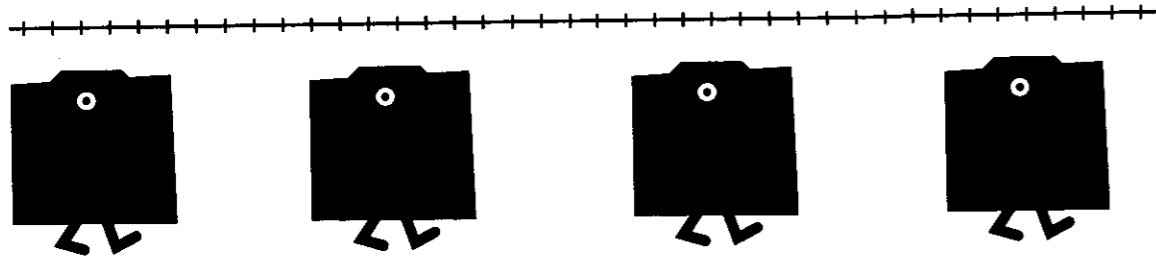

**STOP AND THINK ABOUT IT.  
THESE BEHAVIORS HAVE CONSEQUENCES!**

- No Balance sheet : \$10 fine
- Balance sheet returned but not signed: \$5 fine
- No binder/folder: \$1.50 (responsibility fine)
- No uniform: \$5 fine first time, \$10 fine thereafter
- Sagging: \$5 fine first time, \$10 fine thereafter
- Secretive behavior: \$5
- Pen charge: \$10 to rent a pen (you get \$6 back if you return the pen the same day you borrowed it)
- No H/W: \$1.50 fine first day, increasing by .50 every day up to \$5 (per event)
- Weekly attendance: \$1.50 award; daily attendance = .50 award
- Lunchtime Etiquette: \$1.00/day (DINING DOLLARS)

**MAKE WISE CHOICES. WE KNOW YOU CAN!!!!!!**

**ONGOING CONSEQUENCES**

Whenever a student does not respond appropriately, the first time, a staff issues a consequence for negative or inappropriate behavior, the student will receive up to five additional consequences whose negative dollar values are listed below:

Consequence	Fine (subtract)	Practice (add)
1 <sup>st</sup>	(-) .50	.25
2 <sup>nd</sup>	(-) 1.00	.50
3 <sup>rd</sup>	(-) 2.00	1.00
4 <sup>th</sup>	(-) 3.00	1.00
5 <sup>th</sup>	(-) 5.00	1.00

After five consequences, the process stops until the student is in a better place to cooperate and learn from the experience.

**Cafeteria Expectations**

- Students and staff will observe a moment of silence at the beginning of lunch
- Three students at a time may go to the serving line to get their lunch when told to do so by staff
- Students will use appropriate table manners and voice volume and tone while eating lunch
- Once seated for lunch, only one student at a time may get back up (with staff's permission) Students should not need to repeatedly go back and forth to get items
- After each lunch period, students will wipe/clean ALL tables (and chairs and floors if needed) before leaving the cafeteria
- The last five minutes of lunch will be silent to prepare for transition
- Show respect and consideration towards the staff who serve lunch and also to those who use the workspace around the lunchroom – say please and thank you, move chairs quietly, etc

**Silent Lunch-**For students who have failed to complete homework or are displaying

- These students will go to the serving line last
- Students may not read, write, draw, do other activities, or speak to others *unless* they have a specific question about lunch and *if* they raise their hands
- Students who are not following expectations will be taken back to the school to eat
- There will be a fine for talking during silent lunch

## CLASSROOM RULES

Be prepared for class

- Have your pen/pencil, binder, homework, and balance sheet

Participate appropriately

- Complete all assigned work
- Raise your hand and wait for permission to speak or get out of seat
- Focus on yourself – IGNORE negative behaviors of others
- Respect and maintain appropriate boundaries with peers and staff
- Heads up, eyes open

Focus time may be taken in designated area with staff permission

Eliada-issued uniforms must be worn at all times

- No sagging pants
- Hang up your coat
- Hooded or over-sized sweatshirts are not allowed

Water in a clear bottle is the only beverage allowed in class

- No gum, candy, snacks, soda, juice, etc.

Restroom breaks will be taken during the last 15 minutes of class

## III. ACADEMY PROCEDURES

**Search and Seizure**

- Students may arrive at Eliada Academy for Search and Seizure beginning at 7:40 AM.
- Boys report to B1.
- Girls report to the Computer Lab.
- Once students have arrived in the respective classrooms or area, staff will record the arrival time and will thoroughly search all pockets, shoes, waistbands, bra straps and binders.
- Students will also be searched using a security wand.
- Any items that are confiscated (weapons, contraband, wallet, money, cell phone, chains, makeup) will be given to the student's Case Manager. The item(s) may be returned to the students at the end of the day or to parents at the student's next Child and Family Team meeting.
- Students will be issued new daily balance sheets during this time.

- Teachings will begin during this period.
- Students will transition to their homerooms at 8:06 AM.
- Students arriving after this transition will be considered tardy.

## Binders

### Students:

- Use Eliada-issued binders (3-ring binders that are all white) only.
- May not keep anything that shows on the outside of their binder, other than a school schedule.
- Inside of the binder, students may keep notebook paper, balance sheets, assignments, etc.
- The only items that are permitted in the front or back pocket of the binder are:
  - Eliada Academy balance sheets
  - NYPUM goal sheets
  - Homework that is due that day
- Everything else must be three-hole punched and put into the rings of the binder. Binders must be kept organized at all times.

## Transitions

- Transitions are to take place 5 minutes prior to the beginning of the next block.
- The students will stand in a line, male students lined up in the front, female students in back
- Only exit the room when instructed by an adult
- Transitions are to be quiet (no talking, singing, laughing, etc...).
- Students are to keep hands and feet to themselves during transitions (as they are during all other times).  
within an **arm's length** of each other
- Walk **SLOWLY (NEVER RUN!)** Step on each stair and do not jump the steps or skip steps.
- Students must be in staff eyesight at all times and are transitioned to their next room until they are under the direct supervision of the waiting staff
- Go **UP** the **front staircase** and **DOWN** the **back**
- Always remember to **stop** at EACH designated "**stopping point**" and wait for the "**OK**" before continuing
- **NEVER jump** to try to reach ANYTHING above you
- When arriving at your destination, **line up** quietly **BEFORE ENTERING** the room. Stay within **arm's length** of each other and wait for the "**OK**" before entering the room

## PM Line-up

- **At the end of the day:**
  - Students are required to wait in front of the Academy for their respective transportation to pick them up
  - Students come outside in groups from their 4<sup>th</sup>-block classes
- **Students line up on Sidewalk in front of Academy and face forward toward PM Duty Staff**
  - Boys are to form a line to the left of the sidewalk
  - Girls will line up on the right of the sidewalk
  - Students are to have one foot on the grass and one foot on the sidewalk
  - Students remain one arm's length from each other and staff
  - Students are to remain quiet, orderly and in line until they are dismissed to their transportation
- **Students will:**

- Raise their hand when their transportation arrives
- Wait until the staff responsible for the PM line acknowledges him/her and verifies transportation
- Ask to get on their transportation
- Students must WALK to their transportation
- **Personal belongings from AM Search and Seizure will be outside.**
  - Students raise their hands and ask permission to collect their personal items from the AM Search and Seizure crate
  - Staff will assist students in collecting items from the crate
  - Items left in the crate for a week may be donated to charity if left unclaimed

### **Attendance/Tardy Policy**

Eliada Academy believes that that daily attendance is essential for a student to meet his/her treatment and educational goals and that experiences in the classroom are necessary components of the learning process and time lost from treatment cannot be recaptured in any meaningful way. \_\_\_\_\_ (initial)

By law, parents/guardians are required to send their child to school every day. \_\_\_\_\_ (initial)

Students at Eliada Academy are admitted to Day Treatment to *work on their treatment goals and to change behaviors*. Because this is a treatment program first and a private school second, students are expected to be in attendance every day that the program is open. Absences are neither excused nor unexcused. When a student is not present, he or she is absent from treatment, regardless of the reason. \_\_\_\_\_ (initial)

***When a student has accumulated five (5) absences in one semester or within nine weeks of admission, a letter will be sent to the parent/guardian and other members of the Child and Family Team restating the expectations for attendance and notifying them that they may be in violation of the Compulsory Attendance Law.*** \_\_\_\_\_ (initial)

Absences over five days will require an emergency Child and Family Team meeting. A plan for attendance and accountability will be developed and implemented immediately. \_\_\_\_\_ (initial)

Absences over ten days in one semester or within nine weeks of admission will result in truancy charges being filed with the court system. \_\_\_\_\_ (initial)

**Immediate discharge** from Eliada Academy may be considered if any of the following exist:

- Five consecutive absences without prior approval from the Director and Case Manager.
- Medical condition necessitates long term medical care that may prevent participation in the program
- Excessive tardiness

\_\_\_\_\_ (initial)

When a student misses school for the following reasons, consideration may be made in the decision of whether or not to press charges of truancy:

- Illness or injury (a temperature over 101 degrees and/or vomiting or by a doctor's order)
- Order for isolation by local health officer or the State Board of Health
- Death of a member of the immediate family
- Court appearance
- Prior approval by the director to be absent due to the observance of an event required or suggested by the religion of the student or the student's parents/guardian.

- Extreme Weather Conditions

\_\_\_\_\_ (initial)

Appointments for routine doctor or dental care, therapy, haircuts, etc. must be made outside the school day (Before 8:00 AM or after 3:00 PM) or the absence will count toward the total absences for the student. If a student must be absent for such an appointment, every effort must be made to return the student to school as soon as possible during the school day. \_\_\_\_\_ (initial)

When a parent/guardian anticipates a student's extended absence because of a severe, prolonged or chronic illness under a physician's care, the parent shall notify the Director, Program Manager or Case Manager. If the student makes a good faith effort to complete assigned work under these conditions, days missed will not be counted against the student. In this instance, the attending physician must provide written documentation of need. \_\_\_\_\_ (initial)

Students failing to meet attendance requirements may not be promoted or receive credit for course work.

\_\_\_\_\_ (initial)

Students are expected to arrive on time (by 8:00 AM) and remain in school the full day (2:45 PM.) Following are the consequences for arriving late or leaving early:

1<sup>st</sup> occurrence = verbal warning; Case Manager will contact parent or guardian

2<sup>nd</sup> occurrence = silent lunch; Case Manager will contact parent or guardian

After the third occurrence, additional consequences may be implemented.

\_\_\_\_\_ (initial)

Being tardy or leaving early five or more times will equal one absence.

\_\_\_\_\_ (initial)

Students have two days for each day absent to make up assignments for full credit. Late work will be graded according to teacher policy. \_\_\_\_\_ (initial)

My signature below indicates that I have read and understand this attendance policy and that I will adhere to the requirements as part of my treatment plan.

Student Signature / Date

Guardian Signature / Date

## Grading

### Homework Points

Students will receive a 0, 1, 2, or 3 for homework assignments based on the following:

3 points – full assignment is complete

2 points – most of the assignment is complete (i.e. 15 out of 20 problems)

1 point – half of the assignment is complete

0 points – none of the assignment is complete

*\*Separate homework grades can also be given based on the percentage accurate. Students should be notified when this occurs.*



In order to receive the maximum amount of points for homework assignments, it must be turned in by the assigned date. For each day that the assignment is turned in late, one point will be deducted from the possible points. For example: If a student completed the entire assignment but turned it in late, he or she would still be able to earn two points. If the entire assignment is complete but turned in two days late, they would only receive one point.

### Warm-Up Points

Each class must begin with a warm-up activity that the students complete in their spiral notebook. The warm-up is worth a total of five points. Teachers may choose how to decide what parts of the warm-up earn for what amount of points. For example: a student may earn 1 point for writing the date, 1 point for recording the objective, and 3 points for completing the actual warm-up activity. It is suggested to record the total points on their paper as they finish the warm-up so the students receive immediate feedback.

### Grading Scale

A = 91 -100

B = 81- 90

C = 71 - 80

D = 61 – 70

F = 0 – 60

### Grading Period

Grading periods will be approximately nine weeks long.

### Participation/Behavior Points

Students will earn a possible five P/B points for each class period. These points should be reviewed with the students each day so they understand why the specific number of points was earned. Each teacher/staff can develop their own system for determining the number of P/B points a student earns. P/B points are not affected if the student uses the focus area, only if they do not compile with the expectations for that use.

### Grading Categories

There are five grading categories for students, which include: Participation, Warm-ups, Class work, Homework, and Tests/quizzes. Each category should be weighted. The weight of each category is up to the individual teacher; however, homework should NOT count for more than 10% of the overall grade. Teachers should inform students of the weights for each category at the beginning of the semester and when new students are admitted.

### Student Folders

Each student should have a two-pocket folder in each academic class. Work that needs to be turned in for grading should be put in the left side (“In”) and when the teacher grades the work, it should be returned to the



student via the folder on the right side ("Out). This folder, along with the spiral notebook should be kept in the hanging files in each room.

#### Grade Review

Teachers should provide updates to the students on their individual grades every two weeks. This can be completed by providing a print-out of the grade summary or reviewing their grade and assignments on the computer. Progress reports will also be completed one-half way through the grading period.

#### **Credits**

**Credits for High School Students:** Receiving schools have the right to reject or accept our credits, with the exception of the English I or Algebra I (EOC course/tests and required for a NC diploma)

- **English I/Algebra I:** A student must be passing the class and pass the EOC test (25% of the total grade) to receive credit for the class
- **Intro to Math, Geometry/Algebra II/Intro to English; English II, English III:** one credit can be earned for one semester's class if passed (see grading scale in handbook)
- **Life Skills:** One credit/semester for passing

We do not do a senior project and cannot give an English IV credit.

Teachers in the Academy occasionally teach a semester class that is not English or Math and credit may be given if the number of hours required for a HS level class is met.

Students in elementary and Middle School classes do not get credit. We do give the EOG tests to students who are at a place in their treatment that the testing experience would not be a negative one. Very few students are able to pass these tests because we do not teach a full complement of the NC Standard Course of Study and the spotty attendance of most of our students in previous educational programs.

We do not promote or retain students in treatment. Our objective is to help them stay at the achievement/grade level with which they come to us. We give the students multiple opportunities to improve their basic math and reading skills through Title One and other academic experiences. Our student often make significant gains in these areas, which will help them be successful in their future academic endeavors.

Students may earn partial credit for courses, if they are passing and have spent an adequate number of hours attending the class and are earning a passing grade. Examples:

- One marking period of Math or English = .5 credit in English 1A;2A;3A; Intro to Math A; Algebra 1A etc.
- Time in electives may be lumped together for a .5 credit; or a marking period of TASC or NYPUM (daily) for a .25 credit.
- And so on...
- The receiving school will ultimately determine which credits they accept in the transfer and this way, we give as much credit as possible to students for the work they do here. This will also help in the situations when students must transition before the completion of a semester.

#### **Homework**

Homework is a necessary part of every student's education and at Eliada Academy we believe students need the additional academic practice that homework provides.

- Monday-Thursday nights, 20-30 minutes of homework will be assigned from each academic class.

- Homework is to be completed and turned in the very next day for full credit, unless authorized by Day Treatment staff.
- Students will pick up a new Homework Log during homeroom Monday-Thursday.
- Students list all homework on the Homework Log in each academic class.
  - Students are responsible for having a staff member sign their homework log in each class. If there is no homework, the staff will write “no homework” on the log and sign it.
  - A parent or guardian must sign the homework log at night, indicating that they have seen the assignment and made every effort to provide space and time for the student to complete their assignments.
  - Students return the signed homework log the very next day, along with the signed Balance Sheet.
- Students will receive a responsibility fine (\$1.50 on Silver and .75 on Bronze) and Silent Lunch if their homework is not completed and turned in on time.
  - Fines for homework increase by .50 every day the homework is not turned in.
  - The maximum fine is \$5 for Silver and \$2.50 for Bronze.
  - The fines continue until homework is completed for five consecutive days.
  - Students, who fail to complete homework for more than five days in nine weeks, may also be assigned to lunch detention in the Academy building.
- When all students in a class complete homework, the entire class earns a bonus. (\$1.50 for Silver and \$0.75 for Bronze)
- At random times, students who complete homework will receive an extra privilege or treat.

### Dress Code

Eliada Academy students wear uniforms (pants, polo shirt and long-sleeved oxford.) Eliada provides two uniform shirts. Parents/Guardians are responsible for supplying appropriate khaki pants and if needed, purchasing additional navy blue or forest green polo shirts (no designs or patterns.) Uniforms reduce fashion distractions, decisions about what to wear, and you can't beat the price!

- All students are expected to wear the school uniform as issued
- Uniforms are to be kept clean and in good repair at all times
- Tattoos must be covered at all times
- One necklace, small rings and/or small earrings may be worn (if any provide a distraction, they will be confiscated and given to the Case Manager who will give them to the parent/guardian)
- Appropriate footwear (i.e. shoes) must be worn at all times. (no high heels, crocs/flip-flops, boots, steel-toed shoes or slippers) Athletic shoes are the best choice as students will be outside frequently
- Visible body piercings and/or facial piercings are not allowed/ facial jewelry may NOT be worn at any time. *Do not get new piercings while in treatment – you will be required to remove the hardware!*
- Hooded sweatshirts, with or without a zipper, are NOT allowed
- NO SAGGING! Wear a belt! Pants and shorts must be worn on or above the hips (i.e. no sagging and no covering sagging pants with a shirt)
- Do NOT wear jeans, shorts, or other types of leg wear under uniform pants
- Hats, bandanas, or other head coverings may not be worn during school hours inside or outside the building (unless approved by staff in inclement weather)
- No clothing may be worn that is considered unsafe, dangerous, or is a health hazard
- Clothing may not have any logos or images that contain or refer to language that is derogatory or is oriented toward sex, violence, drugs, alcohol, tobacco, or other illegal activities.
- No visible undergarments allowed

- Solid color T-Shirts may be worn under uniform shirt (no gang colors, etc.)
- All shorts must be no more than ½ inch above the knee
- Skirts and dresses are not part of an Eliada Uniform and are not to be worn except for special occasions and with permission of the Director
- Dress appropriately for the weather (jacket, sweater, long sleeves, etc.)

*Staff has the final authority as to whether or not clothing or accessories are appropriate.*

**Students will wear school uniforms while out in the community when part of school-sponsored field trips.**

### **Cafeteria**

- Students and staff will observe a moment of silence at the beginning of lunch
- Three students at a time may go to the serving line to get their lunch when told to do so by staff
- Students will use appropriate table manners and voice volume and tone while eating lunch
- Once seated for lunch, only one student at a time may get back up (with staff's permission)
- After each lunch period, students will wipe/clean ALL tables (and chairs and floors if needed) before leaving the cafeteria
- The last five minutes of lunch will be silent to prepare for transition

### **Inclement Weather Information**

Decisions about school closings or delays will be based on the needs of the students and the safety of the staff. In the case of extremely bad weather and unsafe driving conditions Eliada Academy will delay opening or close on scheduled school day. All students are expected to attend on days when school is delayed and opens later than the usual time.

**When a two-hour delay is in effect, school will begin at 10:00 AM and dismiss at 3:00 PM.**

All students should *arrive at school no later than 9:45 AM* to check in for Search and Seizure. Parents with a child riding a van or taxi will need to confirm the change in scheduling with their transportation provider.

**ELIADA ACADEMY DOES NOT AUTOMATICALLY FOLLOW THE DECISION OF BUNCOMBE COUNTY OR ASHEVILLE CITY SCHOOLS WHEN DETERMINING THE NECESSITY OF A SCHOOL CLOSING OR DELAY.**

We are not the same as Eliada Child Development. Please look for an announcement for Eliada Academy. Announcements for a delay, early dismissal or school closing will say **ELIADA ACADEMY** and be posted on the following media stations:

- WLOS13 – ABC13      [www.wlos.com](http://www.wlos.com)
- WMYA – MY40      [www.my40.tv](http://www.my40.tv)
- KISS 99.9      [www.99kisscountry.com](http://www.99kisscountry.com)
- Star 104.3      [www.star1043.com](http://www.star1043.com)
- Rock 104.9      [www.rock104rocks.com](http://www.rock104rocks.com)
- 880am The Revolution      [www.880therevolution.com](http://www.880therevolution.com)

- 570 WWNC [www.wwnc.com](http://www.wwnc.com)
- FOX Carolina [www.foxcarolina.com](http://www.foxcarolina.com)

**In the event that too many school days or hours are missed, make-up days will be announced.**

## **Fire and Weather Drills**

Exit routes for fire and weather drills are posted in each classroom. Monthly fire drills will be practiced by all students and staff.

Once the alarm sounds:

- Students should stop what they are doing and file out of the building quietly
- Students do not need to bring binders or other materials out of the building during a fire drill
- Staff must bring their attendance book/log with them when they leave the building for a fire or weather drill
- Staff will turn out the lights and close the door to the classroom on the way out of the building
- Students and staff coming out of the main entrance to the building should go across the street in front of the Academy
- Students leaving the building out of the back stairwell should assemble by the picnic areas
- Staff for each class should call on the radio when they have exited the building
- Students are to stand quietly in the designated area with no talking
- Staff will be notified via radio when it is safe to return
- Students should earn a positive once they have returned to their classrooms if they have followed expectations, or a fine if they have not

## **Therapy and Treatment Group Expectations**

### 1) RESPECT

- Appropriate voice tone
- Appropriate body language
- Appropriate words.
- Don't talk over others.
- No side conversations.
- No secretive behaviors – like mumbling under breath.

### 2) PARTICIPATION

- Appropriate body posture (sit up, head up)
- Actively listen.
- Appropriate sharing – offer information, share your experiences, keep it related to the topic.

### 3) CONFIDENTIALITY

- Do not share personal information about others outside of group context.
- You may share your own experiences in group but not others' experiences.
- You may talk about skills and educational information outside of group.

### 4) TEACHINGS

- Students do not earn fines in group but will earn strikes which are accompanied by fines.
- Therapist or staff can issue a strike.
- Strikes will be tallied at the end of group.

- d. Students may earn for participating which will also be tallied at the end of group.

## **IV. ELIADA HOMES ENHANCED SERVICES**

### **TASC (Therapeutic Animal Stewardship Cooperative)**

Eliada Homes, Inc.'s (EHI) Therapeutic Animal Program provides animal-assisted therapeutic activities for high-risk students with behavioral and emotional problems. TASC activities are helpful for children and families who have difficulty with emotional closeness, interpersonal skills, self-confidence, focusing, impulse and anger control, animal abuse history, and those who refuse to accept responsibility. TASC is an interactive, educational, cognitive-behavioral approach custom-tailored to offer participants and their families success-based therapeutic activities to help them achieve their treatment goals. Activities reflect and trigger dysfunctional behavior, feelings and attitudes. These responses are discussed and used as a metaphor in how students and their families relate to one another in their daily life. Students are taught how to provide the daily care for the horses, including work days specifically related to horse care. Appropriate communication and assertiveness are taught through working with the horses and by riding them.

Admissions Criteria: Children ages 5 and up

Program Components:

- Strengths-based goal setting and evaluation for each activity.
- Development of self-confidence and self-esteem through handling large, strong animals. Improved communication skills through correct measures used to achieve the desired response from a horse. Increased concentration and attention span through managing and controlling the horses. Greater awareness of personal feelings experienced through caring for and riding the animals.
- Knowledgeable staff extensively trained in EAP (Equine Assisted Psychotherapy), the Eliada Model (based on the Positive Peer Culture and the Teaching Family models), group facilitation, team work and clinical issues.
- TASC Director meets Qualified Professional qualifications.
- Current TASC family includes 13 horses, 1 donkey, 1 llama and 4 cats.

### **NYPUM (National Youth Program Using Minibikes)**

- \*Students must have at least 3 signatures per goal each week.
- \*Jr. Leaders must have 4 signatures per week.
- \*Those students on BRONZE must go by the 'Yes / No' system. More than three 'No's per week will result in the student not being able to ride.
- \*If they bring in the necessary signatures, they are eligible to participate in NYPUM and it counts, on the balance sheet, as a homework assignment.
- If they do not have the necessary signatures, they are not eligible to participate and are fined accordingly on the balance sheet. The fine is for "responsibility/no homework."
- Not being eligible to participate in NYPUM will result in NYPUM-related duties being assigned.
- Never EVER get on a dirt bike without permission from the NYPUM instructor
- Do not pick up any tools or go into the tool box without permission from the NYPUM instructor.
- Any aggressive or disruptive behavior will result in the student being taken out of the class.
- Put all gear in its appropriate place when finished.
- Put away all tools or anything else used in class.

## Driving Range & Golf Shed

### Facility maintenance and upkeep:

- Staff is responsible for ensuring equipment is returned to its proper place.
- Only two students are permitted in the shed at a time.
- Rotate areas of play as to let damaged areas of grass heal and grow.
- Mats should be used when the ground is soggy.
- Junior golf clubs on the side of the half-wall are for day care, after-school and summer camp use and are NOT to be used by Eliada Academy or Residential Cottage students.
- Divots should be filled at the end of class with sand from the green boxes.
- Staff is responsible for ensuring equipment is returned to its proper place.

### Safety rules must be reviewed at the beginning of each class:

- Students must remain a safe distance away from one another while practicing.
- Each student should have on closed-toed shoes to participate in golf.
- No one can move in front of the line from which are all golfers are hitting until an instructor tells them they can move from their designated area.

### Succession of club usage and course play:

- Students will progress through learning to use irons and then woods / drivers. Students should not be given drivers or fairway woods until they are able to demonstrate an understanding of a proper golf swing.
- The USGA has donated funds for students to play on local courses. If you would like to take a small group of students golfing or if you have a student who would use a gift certificate to a course, please let Laura Elliott know. We have these funds for the spring and summer sessions.

## Climbing Wall

- Voice volume and noise level in the gym must be maintained at a level that each climber and belay staff can clearly hear one another.
- Proper athletic wear including appropriate athletic shoes must be worn to climb and belay. Climbers must have on closed toed shoes. Belayers must have shoes that are securely attached to their feet.
- Only the student(s) in the process of climbing, staff spotters and staff belayers may be on the mats. Everyone else must be behind the belay station cones.
- All climbers must have a harness properly tied to the climbing rope and have completed belay commands before climbing on the wall. Bouldering or free climbing is not permitted.
- All students must wear helmets while climbing.
- Climbers should NOT use the green handles that secure the mats as climbing holds.
- Only Eliada Certified Belayers are permitted to belay students on the wall, check equipment, give a safety talk or teach basic climbing techniques.
- If more than one student is in the upstairs of the dairy barn and one student or more will be climbing, there must be more two or more staff present. The staff belayer must be solely focused on the climber. When there is more than one student in the dairy barn, the # of staff = # of people climbing simultaneously + 1.
- Any safety concerns must be reported immediately for supervision.
- All equipment must be properly secured at the end of each class.

## Weight Training

- Accept all staff decisions and consequences.
- Be safe
  - Don't push yourself too much
  - Always have a spotter—never lift alone
  - Raise hand to ask permission before you try a new skill
  - Use appropriate techniques—"it is not a race"
- Respect others.
- Be mature.
- Listen to and follow instructions.
- Maintain appropriate boundaries at all times.
- Water is the only beverage allowed.
- Put away all weights and equipment when you finish with an exercise.
- Leave the weight room in better shape than you found it.

## Eliada Pool

- At the first sign of thunder or lightning all students must exit the pool for 30 minutes.
- No splashing others.
- No diving and no jumping in shallow end.
- No hanging on tow line.
- No secretive behavior.
- Swimmers are under instruction of lifeguard as well as staff.
- Boundary expectations in the Academy apply at the pool.
- Toys must be used appropriately; otherwise swimmers will be unable to use them.
- If there is only one life guard on duty the kid's pool will not be used.
- Students who wish to swim in the deep end of the pool must pass a swim test by swimming the width of the shallow end of the pool twice without touching the bottom.
- Review posted rules.

## VI. BASIC SKILLS CURRICULUM

### Basic 10 Skills to Master:

#### Listening (E1)<sup>1</sup>,

- Look at the person who is talking.
- Sit quietly.
- Think about what is being said.
- Say yes or nod your head.
- Ask a question about the topic to find out more.

#### Following Instructions (E5)

- Listen carefully to the instructions.

- Ask questions about anything you don't understand
- Repeat the instructions to the person (or yourself).
- Follow the instructions.

#### Asking Permission (E37)

- Decide what you want to do
- Decide whom to ask
- Plan what to say
- Choose the right time and place
- Ask in a friendly way

#### Accepting Consequences (E42)

- Look at the person
- Say “Okay” or “I understand”
- Maintain positive body posture
- Change behavior

#### **Accepting No (E54)**

- Decide why you were told no
- Think about your choices
- Do something else
- Say how you feel in a friendly way
- Write about how you feel
- Act out your best choice

#### **Knowing Your Feelings (E26)**

- Think of how your body feels.
- Decide what you could call the feeling.
- Say to yourself, “I feel \_\_\_\_\_”.

#### **Expressing Your Feelings. (E7)**

- Stop and think of how your body feels.
- Decide what to call the feeling.
- Think about your choices:
- Say to the person, “I feel \_\_\_\_\_”.
- Walk away for now
- Get involved in an activity.

#### **Relaxing (E56)**

- Decide if you need to relax.
- Take three slow, deep breaths.
- Tighten one part of your body, count to three, and relax.
- Do this for all other parts of your body
- Ask yourself how you feel.

#### **Using Self Control (E36)**

- Stop and count to 10
- Think of how your body feels
- Think about your choices
- Walk away for now
- Do a relaxation exercise
- Write about you feel
- Talk to someone about it
- Act out your best choice

#### **Ignore Distractions (E10)**

- Count to five
- Say to yourself, “I won’t look. I’ll keep on working.”
- Continue to work
- Say to yourself, “Good for me. I did it!”

#### **[1] (E) = Elementary-level steps**

#### **Basic 10 Skills To Master:**

##### **Listening <sup>2</sup>(A1)**

- Look at the person who is talking.
- Think about what is being said.
- Wait your turn to talk.
- Say what you want to say.

##### **Following Instructions (A12)**

- Listen carefully while you are being told what to do.
- Ask a question about anything you don’t understand.
- Decide if you want to follow the instructions and let the person know your decision.
- Repeat the instructions to yourself.
- Do what you have been asked to do.

##### **Asking Permission (A22)**

- Decide what you would like to do for which you need permission.
- Decide whom you have to ask for permission.
- Decide how to ask for permission.
- Pick the right time and place.
- Ask for permission.

##### **Accepting Consequences ( A?)**

- Look at the person
- Say “Okay” or “I understand”
- Maintain positive body posture
- Change behavior

##### **Accepting No**

- Decide why you were told no
- Think about your choices
- Do something else
- Say how you feel in a friendly way
- Write about how you feel
- Act out your best choice

##### **Knowing Your Feelings (E26) (A15)**

- Tune in to what is going on in your body that helps you know what you are feeling.
- Decide what happened to make you feel that way.
- Decide what you could call the feeling.



**Expressing Your Feelings (A16)**

- Tune into what is going on in your body.
- Decide what happened to make you feel that way.
- Decide what you are feeling.
- Think about different ways to express your feelings and pick one.
- Express your feelings.

**Relaxing (A?)**

- Decide if you need to relax.
- Take three slow, deep breaths.
- Tighten one part of your body, count to three, and relax.
- Do this for all other parts of your body
- Ask yourself how you feel.

**Using Self Control (A26)**

- Tune in to what is going on in your body that helps you know you are about to lose control of yourself.
- Decide what happened to make you feel this way.
- Think about ways in which you might control yourself.
- Choose the best way to control yourself and do it.

**Concentrating on a Task (A50)**

- Decide what your task is.
- Decide on a time to work on this task.
- Gather the materials you need.
- Decide on a place to work.
- Decide if you are ready to concentrate.

▪ (A) = Adolescent-level steps

NOTES:

**APPENDIX: TIMELINE FOR START-UP FOR  
ELIADA ACADEMY CHARTER SCHOOL**

<b>TASK</b>	<b>DUE DATE</b>	<b>RESPONSIBLE PARTY</b>
Write and submit application	April 13, 2012	Jan Thomas Marie Jensen Mark Upright Becky Williams
Copy of the application due to local LEAs	April 20, 2012	Mark Upright
LEA Impact Statements due to the Office of Charter Schools	May, 11, 2012	Mark Upright
Host an Open House	October 2012	All
Press Release/Media Update		Development Department
Research Available Grants		Grant Writer
Complete job posting for Teachers and Administrative Assistant	February 2013	Jan Thomas and HR Dept.
Finalize Budget	May 2013	Jan Thomas and TOO
Purchase textbooks and materials		Jan Thomas and Teachers
Interview and Hire Teachers and Admin. Assistant	May 2013	Jan Thomas and Staff
Complete schedule for August start of school	July 2013	Jan Thomas
Teachers complete Pre-service training and Orientation	July, 2013	Teachers
Parent Orientation	August 12, 2013	Jan Thomas and Staff
Open the Doors to the First Day of School for Eliada Academy Charter School	August 19, 2013	ALL

**Eliada Homes, Inc.**  
Asheville, North Carolina

Financial Statements  
and Supplementary Information  
Years Ended June 30, 2011 and 2010

and  
Independent Auditors' Report





## Independent Auditors' Report

To the Board of Directors  
Eliada Homes, Inc.  
Asheville, North Carolina

We have audited the accompanying statements of financial position of Eliada Homes, Inc. (a nonprofit organization) as of June 30, 2011 and 2010, and the related statements of activities, cash flows and functional expenses for the years then ended. These financial statements are the responsibility of the Organization's management. Our responsibility is to express an opinion on these financial statements based on our audits.

We conducted our audits in accordance with auditing standards generally accepted in the United States of America. Those standards require that we plan and perform the audit to obtain reasonable assurance about whether the financial statements are free of material misstatement. An audit includes examining, on a test basis, evidence supporting the amounts and disclosures in the financial statements. An audit also includes assessing the accounting principles used and significant estimates made by management, as well as evaluating the overall financial statement presentation. We believe that our audits provide a reasonable basis for our opinion.

In our opinion, the financial statements referred to above present fairly, in all material respects, the financial position of Eliada Homes, Inc. as of June 30, 2011 and 2010, and the changes in its net assets and its cash flows for the years then ended in conformity with accounting principles generally accepted in the United States of America.

Our audits were conducted for the purpose of forming an opinion on the basic financial statements of Eliada Homes, Inc., taken as a whole. The schedules of program expenses are presented for purposes of additional analysis and are not a required part of the basic financial statements. Such information has been subjected to auditing procedures applied in the audit of the basic financial statements, and, in our opinion, is fairly presented in all material respects in relation to the basic financial statements taken as a whole.

*Johnson Price & Sprinkle PA*

Marion, North Carolina  
November 14, 2011

1  
Johnson Price & Sprinkle PA

**Eliada Homes, Inc.**

## Statements of Financial Position

June 30,

2011

2010

**Assets**

Cash	\$	187,663	\$	569,713
Accounts receivable		648,827		688,606
Other receivables		21,769		56,332
Grant receivable - affiliate		67,480		2,857
Inventory		8,035		9,156
Prepaid expenses and other current assets		37,349		81,151
Property and equipment, net		270,599		208,947
Beneficial interest in perpetual trusts		229,500		202,000

---

<b>Total assets</b>	<b>\$</b>	<b>1,471,222</b>	<b>\$</b>	<b>1,818,762</b>
---------------------	-----------	------------------	-----------	------------------

---

**Liabilities and Net Assets****Liabilities:**

Accounts payable	\$	103,077	\$	141,882
Payroll liabilities		372,882		425,907
Other liabilities		158		28,157
Installment contract payable		4,311		22,328
Long-term debt, net		86,852		97,430
Refundable advance - affiliate		6,467		232,267

---

<b>Total liabilities</b>		<b>573,747</b>		<b>947,971</b>
--------------------------	--	----------------	--	----------------

---

**Net assets:**

Unrestricted		619,076		663,282
Temporarily restricted		48,899		5,509
Permanently restricted		229,500		202,000

---

<b>Total net assets</b>		<b>897,475</b>		<b>870,791</b>
-------------------------	--	----------------	--	----------------

---

---

<b>Total liabilities and net assets</b>	<b>\$</b>	<b>1,471,222</b>	<b>\$</b>	<b>1,818,762</b>
---	-----------	------------------	-----------	------------------

---

The accompanying notes are an integral part of these financial statements.

**Eliada Homes, Inc.**  
**Statement of Activities**  
**Year Ended June 30, 2011**

	Unrestricted	Temporarily Restricted	Permanently Restricted	Totals
<b>Support and revenues:</b>				
<b>Program service revenue:</b>				
Medicaid	\$ 6,933,399	\$ -	\$ -	\$ 6,933,399
State	1,006,984	-	-	1,006,984
County	834,850	-	-	834,850
Private payments	424,277	-	-	424,277
<b>Support:</b>				
Private grants and contributions	9,797	49,188	-	58,985
Federal and state grants	250,098	-	-	250,098
Eliada Foundation, Inc.	148,540	-	-	148,540
Development fee - Eliada Foundation, Inc.	31,500	-	-	31,500
Investment earnings	5,902	-	-	5,902
Change in value of beneficial interest in perpetual trust	-	-	27,500	27,500
Gain on disposal of assets	1,353	-	-	1,353
Fundraising	570	-	-	570
Rents	5,470	-	-	5,470
Miscellaneous income (expense)	(1,940)	-	-	(1,940)
Net assets released from restrictions	5,798	(5,798)	-	-
<b>Total support and revenues</b>	<b>9,656,598</b>	<b>43,390</b>	<b>27,500</b>	<b>9,727,488</b>
<b>Expenses:</b>				
Program services	8,584,591	-	-	8,584,591
Supporting services	1,116,213	-	-	1,116,213
<b>Total expenses</b>	<b>9,700,804</b>	<b>-</b>	<b>-</b>	<b>9,700,804</b>
<b>Change in net assets</b>	<b>(44,206)</b>	<b>43,390</b>	<b>27,500</b>	<b>26,684</b>
<b>Net assets, beginning of year</b>	<b>663,282</b>	<b>5,509</b>	<b>202,000</b>	<b>870,791</b>
<b>Net assets, end of year</b>	<b>\$ 619,076</b>	<b>\$ 48,899</b>	<b>\$ 229,500</b>	<b>\$ 897,475</b>

The accompanying notes are an integral part of these financial statements.

**Eliada Homes, Inc.**  
**Statement of Activities**  
**Year Ended June 30, 2010**

	Unrestricted	Temporarily Restricted	Permanently Restricted	Totals
<b>Support and revenues:</b>				
<b>Program service revenue:</b>				
Medicaid	\$ 6,332,631	\$ -	\$ -	\$ 6,332,631
State	1,166,572	-	-	1,166,572
County	917,138	-	-	917,138
Private payments	425,804	-	-	425,804
<b>Support:</b>				
Private grants and contributions	53,800	5,000	-	58,800
Federal and state grants	259,051	-	-	259,051
Eliada Foundation, Inc.	232,407	-	-	232,407
Development fee - Eliada Foundation, Inc.	30,000	-	-	30,000
Investment earnings	7,096	-	-	7,096
Change in value of beneficial interest				
in perpetual trust	-	-	16,300	16,300
Gain on disposal of assets	778	-	-	778
Fundraising	766	-	-	766
Rents	17,970	-	-	17,970
Miscellaneous income	2,295	-	-	2,295
Net assets released from restrictions	11,202	(11,202)	-	-
<b>Total support and revenues</b>	<b>9,457,510</b>	<b>(6,202)</b>	<b>16,300</b>	<b>9,467,608</b>
<b>Expenses:</b>				
Program services	8,302,742	-	-	8,302,742
Supporting services	1,162,811	-	-	1,162,811
<b>Total expenses</b>	<b>9,465,553</b>	<b>-</b>	<b>-</b>	<b>9,465,553</b>
<b>Change in net assets</b>	<b>(8,043)</b>	<b>(6,202)</b>	<b>16,300</b>	<b>2,055</b>
<b>Net assets, beginning of year</b>	<b>671,325</b>	<b>11,711</b>	<b>185,700</b>	<b>868,736</b>
<b>Net assets, end of year</b>	<b>\$ 663,282</b>	<b>\$ 5,509</b>	<b>\$ 202,000</b>	<b>\$ 870,791</b>

The accompanying notes are an integral part of these financial statements.



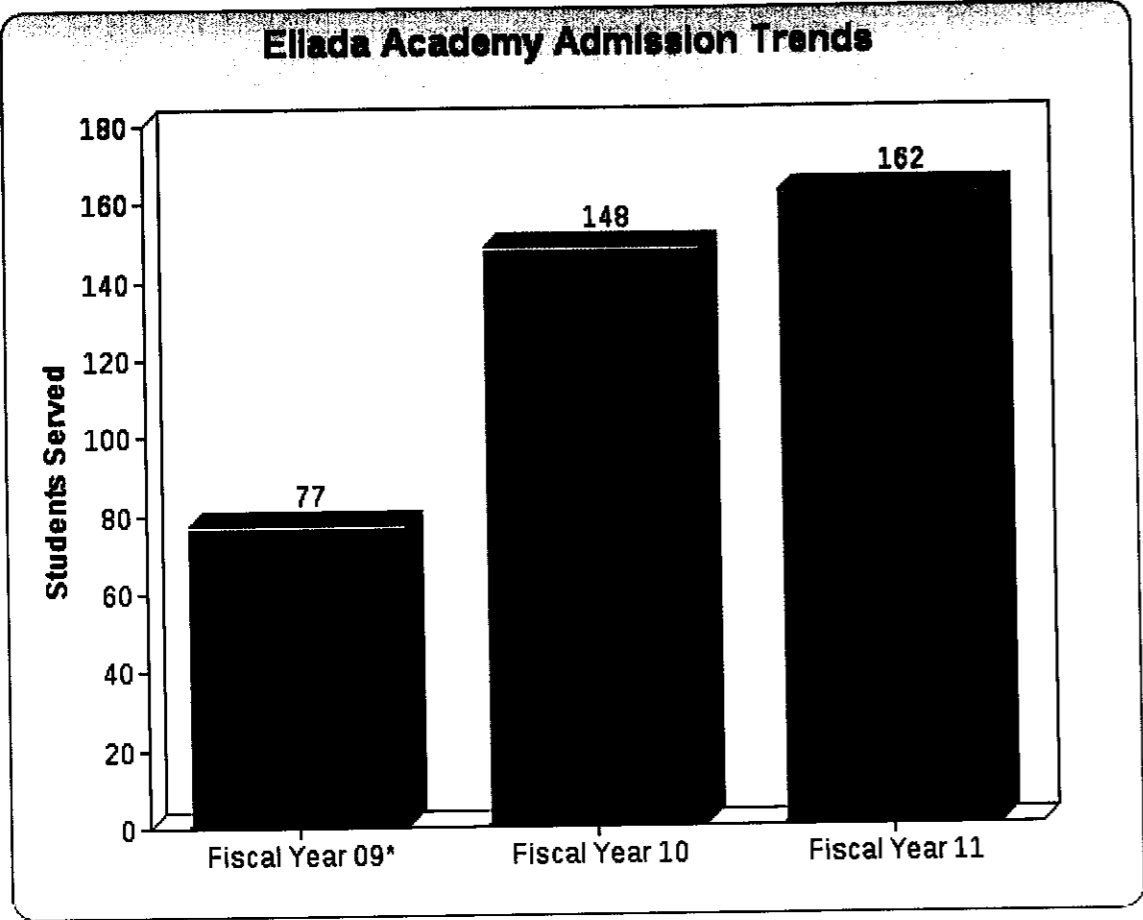

\* Note that from July till October 2009, Eliada was converting from Level III treatment services to a Psychiatric Residential Treatment Facility (PRTF). All Level III's at Eliada were phased out by October 2009. It is possible that there may be a few Level III students included in the Fiscal Year 2009 admission data.

# A Longitudinal Follow-Up

## Current Living Placement

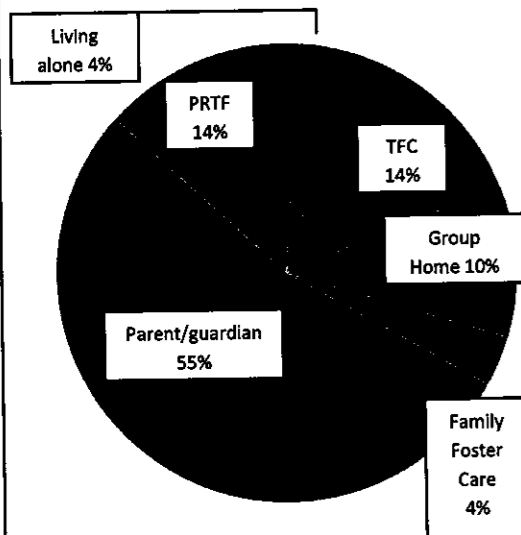

## Discharge Placement

Over fifty percent of students interviewed were living with their parent/guardian. Four percent were living independently. See the graph to the left for specific living placements for survey participants (n=28).

Since discharge from Eliada, 61% have remained in the placement that Eliada discharged them to. And, fifty-six of those students were discharged to the home of their parent(s)/guardian(s). This is a vast improvement when compared to the number of previous placements that students have prior to coming to Eliada.

While 61% of students have remained in the placement that Eliada discharged them to, 48% have had at least 1 placement in which they have returned to their primary placement. Of the 48% with a temporary placement, 31% have only had 1 placement of this type.

## Economic Assistance

Seventy-seven percent (20) of adults interviewed claimed that they were (or the child) was receiving government assistance in the form of food stamps, PANF, or SSI.

The average annual household income of participants in this sample was lower than \$20,000 per year. Twenty-five percent of participants had an annual income of \$14,999 or less. Two participants stated that their household income was \$50,000 or more.

### Victim of a Violent Crime?

None of the student's polled have been the victim of a violent crime since leaving Eliada.

### Children?

None of the student's polled have had children since their discharge from Eliada.

Forty-eight percent acknowledge that they are sexually active and of those students, 82% practice safe sex on a regular basis.

## Educational Achievement

When polling students, 76% believe that education is important or very important. Ninety-six percent of parents believe that education is important or very important.

Taking into consideration the age of students, 86% are currently enrolled in school. The bulk of students interviewed are in high school (50%). Four percent (1 student) have a high school diploma and 4% (1 student) have some college. Of these students, 68% attend a public school. See the graph below for type of school students are enrolled in.

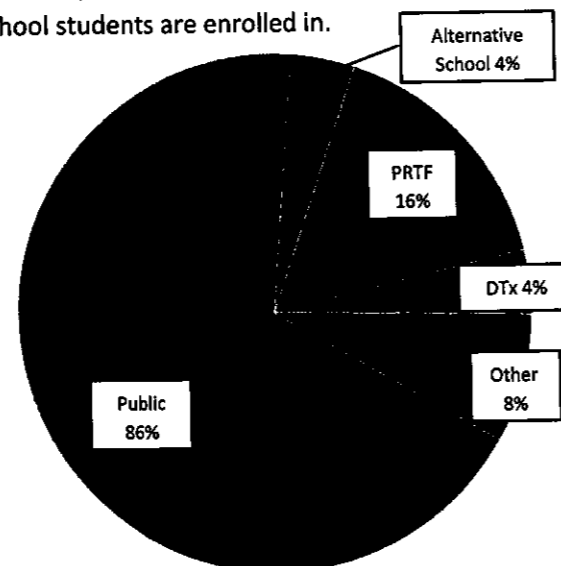

6-12 Mathematics

*Note: For the sake of maintaining anonymity and to be in compliance with HIPAA regulations, students' names have been replaced with initials. All stories are accounts of actual students that made significant progress in math during their time in Eliada's educational program.*

**Student 1: MM**

MM was a 17 year old young woman who came to Reynolds Cottage with a background of severe academic deficiency. This student, under other circumstances would be in the process of graduating; however, she had not completed course work beyond the 9<sup>th</sup> grade. MM had an especially high aversion to math—which she made quite clear during her first few days in my class, where she resorted to an array of inappropriate behaviors—from melodramatic, teary-eyed scenes that monopolized class to angry bouts of yelling, cursing, and throwing textbooks at me—all to avoid engaging in class. After a series of extensive check-ins with her, it became clear to me that while MM possessed the ability to think and reason proficiently with mathematics, her acute anxiety, PTSD and Bipolar symptoms made it nearly impossible for her to believe in her own ability to do math, much less focus her attention on mathematical work. After conferring with treatment staff and the student herself, we were able to create an education plan that gave MM the learning environment she needed to feel comfortable. Combining this with an intensive focus on teaching and developing DBT skills with her in the classroom gave way to a complete breakthrough.

Over time, MM went from a totally noncompliant, math-avoidant student with no belief in herself to a sharp-minded, attentive and engaged young woman who believed in her skills and demonstrated it through her greatly improved work. When MM arrived, she could barely handle basic arithmetic with anything beyond 2-digit numbers; by the time of her discharge, not only was she proficient in arithmetic with rational numbers, but was also capable of operating with and interpreting algebraic expressions, creating and solving one-variable equations, and operating with linear equations. Her disposition toward learning improved so much, in fact, that she has since gone on to complete a GED program and is now seeking enrollment at a technical college for business management. During a phone call back to me requesting a letter of recommendation, MM said that "learning to appreciate math was the best thing that ever happened to me."

**Student 2: RM**

RM was a 14 year old girl who came to Reynolds Cottage with a history of acting out in school and academic non-engagement. As an 8<sup>th</sup> grade student, RM was hardly capable of mathematical operations beyond basic whole-number arithmetic. RM came to Math class on the first day with a sour disposition, stating clearly that she "did not like Math and wasn't going to do it." However, with time RM began to see that failure was not an option in my class, and that no matter how hard she tried to isolate herself and disengage, I was going to keep pushing her and holding her accountable for being a part of the class. I made it a priority to establish a positive relationship of caring with RM, as the Reynolds clinical team identified that her feeling of abandonment was a serious roadblock to her progress. Once RM began to see that I held her accountable for her actions because I cared about her growth and progress, she slowly began to participate more and more in class. As she continued to increasingly engage in class, RM came to see that this "wasn't like most math classes," and stated that she "liked the class" because I "taught

things in an interesting way, always did what it took to reach each student at their level, and never gave up or stopped believing in students." RM continued to blossom into a highly engaged and effective student that was a positive leader for her peers in class. RM's skill developed sharply, as she demonstrated proficiency in rational number arithmetic, operating with algebraic expressions, analyzing, interpreting and representing data and graphs, and operating with linear equations and linear systems. When RM graduated from Reynolds, at her ceremony she thanked me for "showing that math can be interesting, and with practice and hard work anybody can learn it."

Achievement Area	PC	Performance
------------------	----	-------------

**Student 3: DC**

DC was a 13 year old boy who came to Lions Cottage two grade levels behind where he should be for his age with testing data that indicated even lower grade level performance in reading and math. His prior academic history indicated a repeated series of explosive outbursts in class, leading to multiple suspensions and eventual expulsion from public school. From his first day in class, DC was highly oppositional and refused to do any work in class. Often times he would resort to bouts of yelling and/or crying, resulting in being removed from the class. However, after a series of extensive check-ins with DC and his treatment team, we were able to develop an individualized plan for him that led to success. After giving DC the prescribed accommodations in class, he transformed into a gregarious and eager learner that was fun, easy-going, and got along well with his peers. DC's BASI testing data from admission to discharge indicated that he made over one grade level of improvement during his time in Lions, going from a 17% score to a 40% score in Math Computation, and from 20% to 50% in Math Application. Refer to the tables below that highlight DC's scores on the Math section of the BASI at admission and at discharge.

**Admission Math BASI Data for DC**

(PC = Percent

Correct)

Achievement Area	PC	Performance
<b>Math Computation</b>	17	Below Average
Whole numbers	14	Below Average
Fractions	10	Below Average
Decimals, order of operations, percents	33	Below Average
Integers, absolute value	50	Below Average
Algebra	0.0	Average
<b>Math Application</b>	20	Below Average
Whole numbers, money	0.0	Below Average
Fractions, proportions	33	Below Average
Decimals, percents	20	Average
Geometry	n/a	n/a
Algebra	0.0	Below Average
Statistics, probability	29	Below Average
Measurement	50	Average

**Discharge Math BASI Data for DC**

**Eliada Academy "Powerful Progress" Stories**

---

<b>Math Computation</b>	40	Average
Whole numbers	43	Below Average
Fractions	30	Average
Decimals, order of operations, percents	50	Average
Integers, absolute value	50	Average
Algebra	40	Average
<b>Math Application</b>	50	Average
Whole numbers, money	38	Average
Fractions, proportions	50	Average
Decimals, percents	60	Average
Geometry	n/a	n/a
Algebra	100	Above Average
Statistics, probability	50	Average
Measurement	43	Below Average

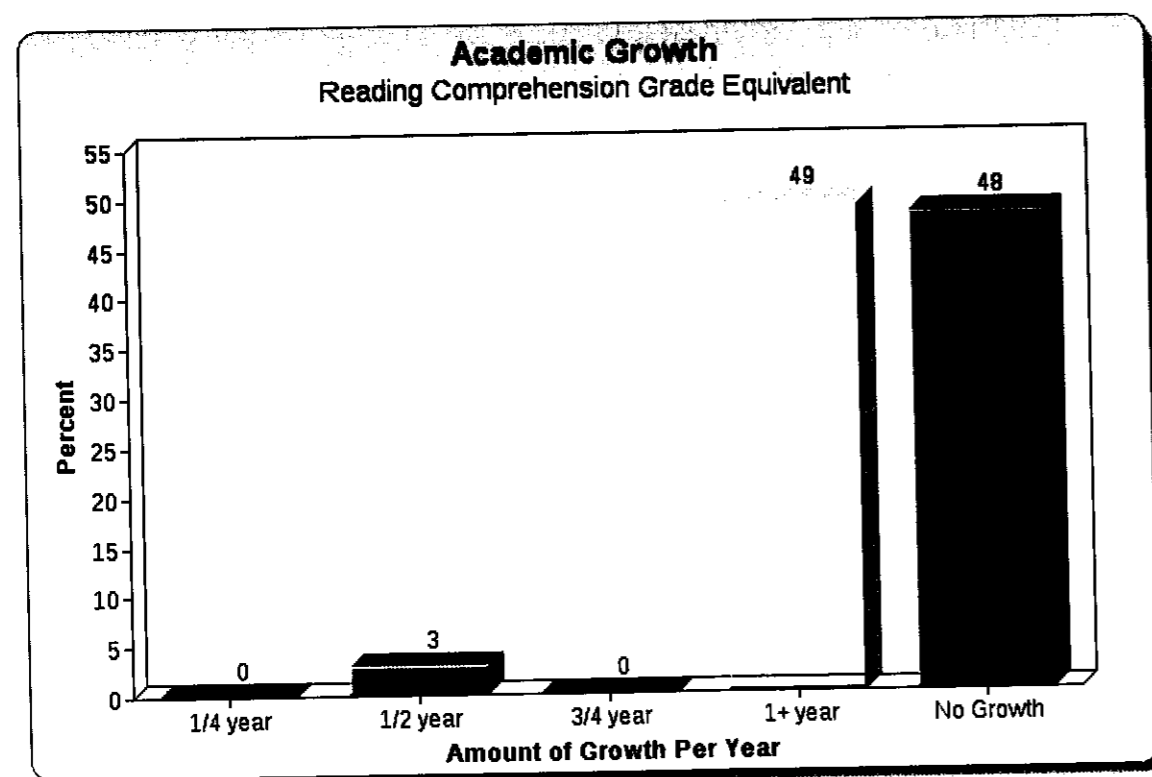
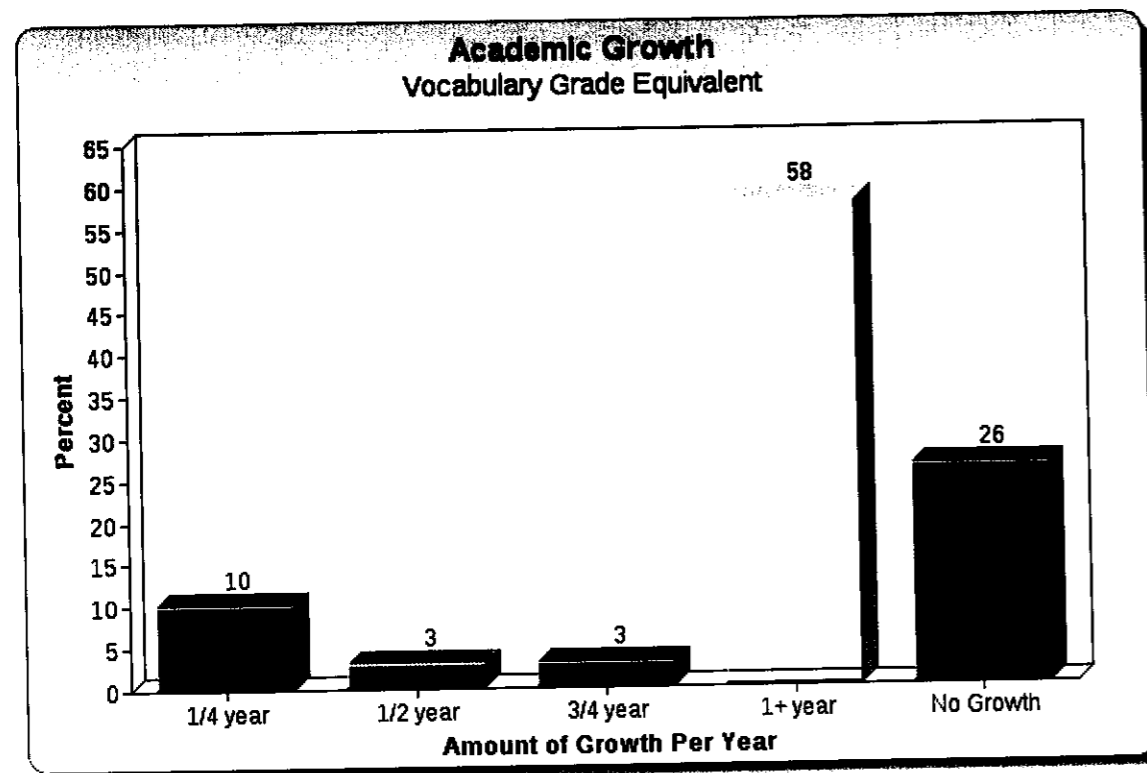

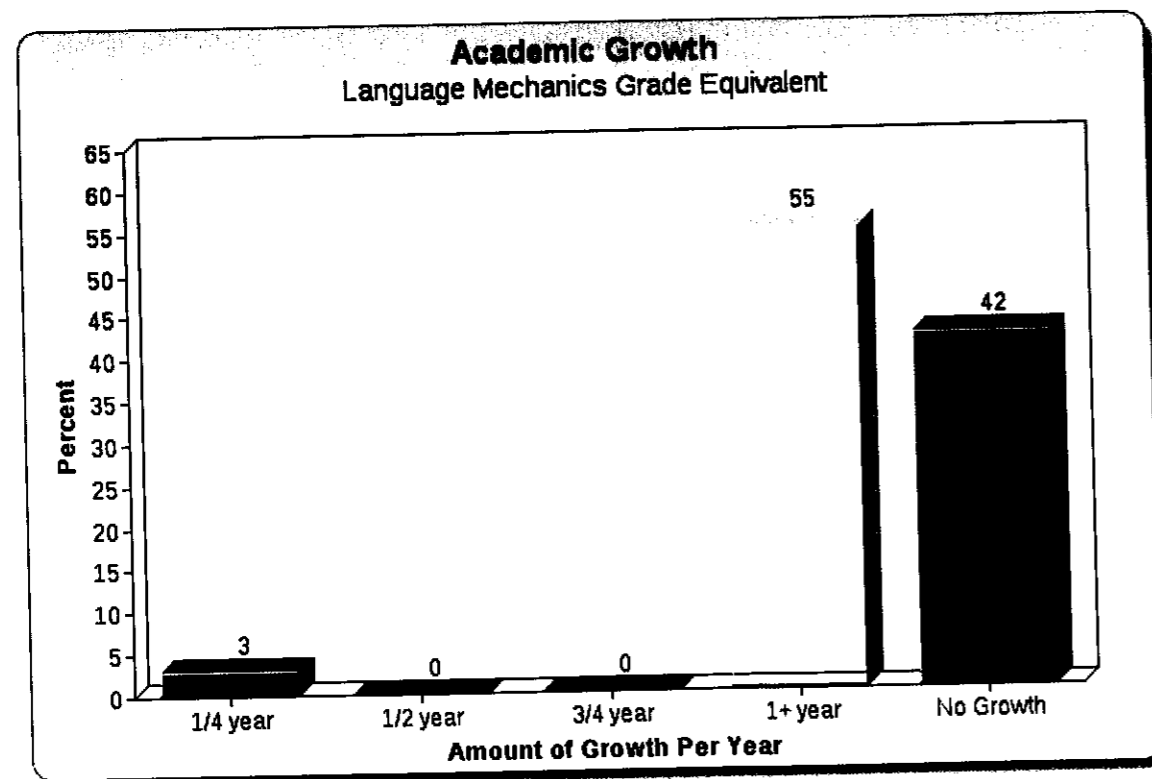
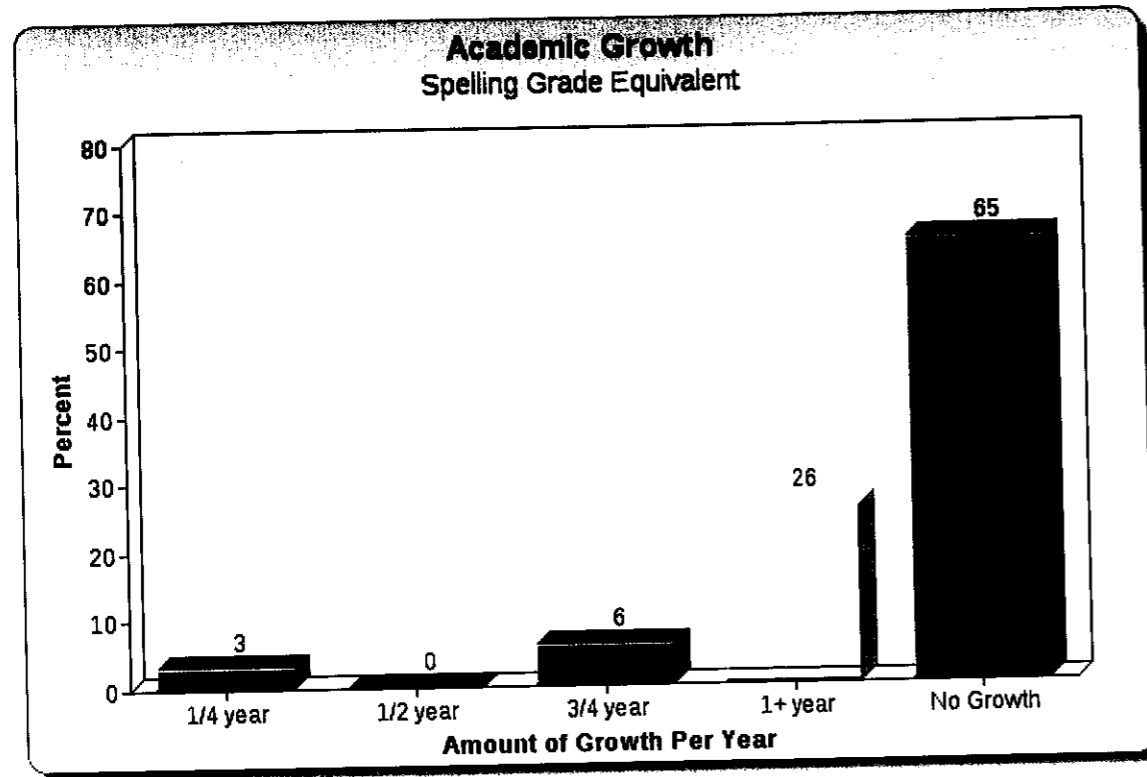

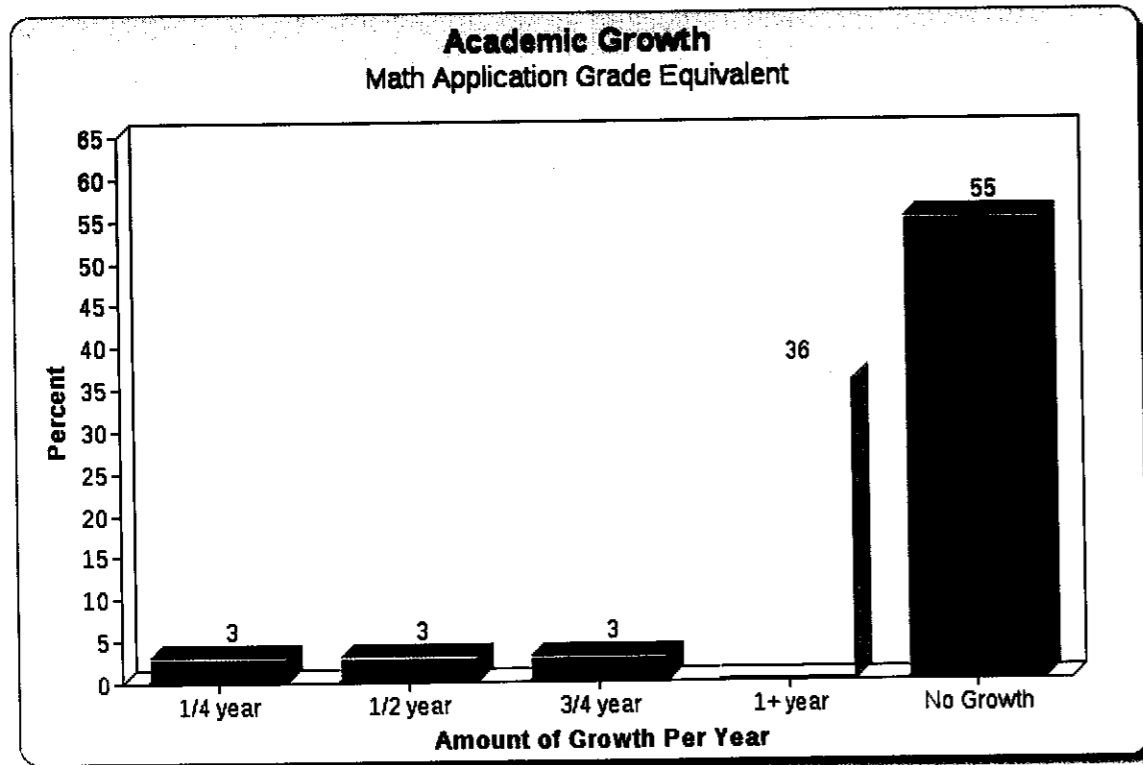
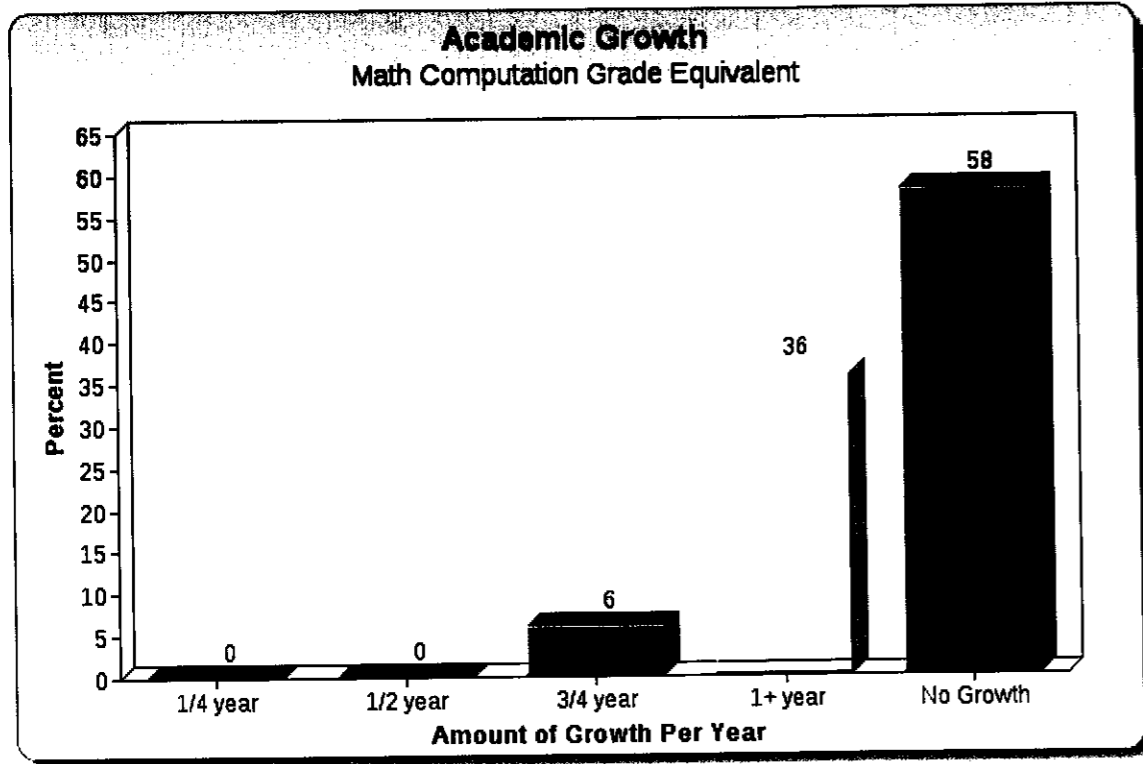



# JAN THOMAS

180 Governors View Road, Asheville, NC 28805 828-226-6692 jthomas@eliada.org

## Public and Private School Administrator

Multi-certified professional educational leader with experience managing and supervising teachers, support staff and treatment professionals. Expert in developing personnel, mentoring new teachers, designing and implementing innovative and revolutionary education and treatment programs for children and adolescents. Proven ability to lead seamless implementations and deliver next-generation educational solutions improving student achievement, educational team function and effectiveness.

### Professional Experience

**ELIADA HOMES, INC.** 2008 to Present

Director of Day Treatment and Education Services

#### Key Responsibilities

- Redesigned the treatment program behavior model to provide more compassionate and effective treatment
- Focused educational efforts on English and Mathematics to assist students in improving their basic skills
- Restructured treatment program to meet Medicaid definition requirements
- Ensures census stability and adherence to budget; Maintains SACS, COA Accreditation and Compliance
- Transformed processes for agency-wide paid time off and sick leave and other agency-wide committee responsibilities

**SMOKY MOUNTAIN HIGH SCHOOL** 2005-2008

Testing, Curriculum and In-School Coordinator for At-Risk Students

#### Key Responsibilities

- All aspects of NC State testing and accommodations
- Support for students at-risk for failure
- Curriculum evaluation, revision and implementation

**PUBLIC SCHOOL ADMINISTRATION-VARIOUS MICHIGAN SCHOOLS** 1988-2005

Principal, Curriculum Coordinator/Director, Teacher, Management

#### Key Position/Schools:

2000-2005	Ithaca Public Schools Middle School Principal	Ithaca, MI
1999-2000	Swan Valley Schools Administrative Assistant for Curriculum	Saginaw, MI
1993-1999	Lake City Area Schools Curriculum Director/Director of Alternative Ed/ Middle School Principal	Lake City, MI
1992-1993	Lapeer Alternative High School Home Economics Teacher	Lapeer, MI
1988-1992	Lapeer County Vocational Technical Center, MI Sales and Marketing Teacher-Tenured Position	
1978-1986	Retail Management: JCPenney, Belk, Rich's	

## EDUCATION

### MA IN SECONDARY EDUCATION

Central Michigan University (CMU), Mt. Pleasant, MI 48859 1988

BA: Home Economics: Fashion Merchandising and Design: CMU 1977

STATE OF NORTH CAROLINA  
STATE BOARD OF EDUCATION • DEPARTMENT OF PUBLIC INSTRUCTION



# Professional Educator's License



DATE ISSUED

07/13/2011  
RENEWAL CYCLE

JAN LAURINE GILCHRIST THOMAS

~~07-13-2011~~

DATE EFFECTIVE

07/13/2011  
DATE EXPIRE

07/13/2011 TO 06/30/2016

THE PERSON NAMED HAS COMPLETED A PROGRAM OF PREPARATION APPROVED BY THE STATE BOARD OF EDUCATION AND IS AWARDED THIS LICENSE TO SERVE IN THE SCHOOLS OF NORTH CAROLINA IN THE AREA(S) INDICATED. THIS LICENSE HAS BEEN ISSUED IN ACCORDANCE WITH STATE BOARD OF EDUCATION REGULATIONS

PROGRAM CODE/STATUS	HO CODE	CODE/AREA	CLASS CODE	EXI
06 STANDARDS PROFESSIONAL II 09 STANDARDS PROFESSIONAL II	05 08	06712 PRINCIPAL (GRADES K-12) 06730 MARKETING EDUCATION (K-12)	P A	7 1

**Class Codes:**  
V Non-Degree level  
A Bachelor's level  
M Master's level  
S, AP, AS, Sixth-year level  
D, DP, DS Doctorate level

**Highly Qualified (HQ) status indicators, pursuant to PL 107-110 (NCLB Act of 2001):**  
98 - Not Highly Qualified  
97 - Not Applicable for Non-Core Academic Areas  
97 - Highly Qualified not determined  
89 - Highly Qualified based on undergraduate academic major  
88 - Highly Qualified based on coursework equivalent to an undergraduate major  
87 - Highly Qualified based on NC licensing test(s)

86 - Highly Qualified based on Other State licensing test(s)  
85 - Highly Qualified based on a graduate degree  
84 - Highly Qualified based on master's level licensure or above  
83 - Highly Qualified based on NBPTS  
82 - Highly Qualified based on NC HOUSSE standard  
81 - Highly Qualified based on Other State HOUSSE standard  
80 - Highly Qualified based on Other State's verification

EACH LICENSE HOLDER IS RESPONSIBLE FOR KNOWING AND SATISFYING LICENSE RENEWAL REQUIREMENTS AND/OR ANY IDENTIFIED PROVISIONS OR DEFICIENCIES REQUIRED TO REISSUE HIS OR HER LICENSE

*Jane St. Clair Atkinson*  
SUPERINTENDENT OF PUBLIC INSTRUCTION

STATE BOARD OF EDUC.  
DEPARTMENT OF PUBLIC INSTRUCTION  
6365 MAIL SERVICE CE  
RALEIGH, NORTH CAROLINA 27698

## Christina David

6 Mountain Dr. Candler, NC 28715

(828) 633-0668

tinadavid100@hotmail.com

### Experience

#### **PRTF Teacher - Eliada Homes, Inc. Asheville, NC**

11/2010 - Present

- Provide differentiated instruction to elementary students of varying grade/ability levels with mental health special needs in a residential treatment facility
- Collaborate with students, program managers, case managers and other PRTF staff to ensure academic as well as therapeutic progress for each client

#### **Teacher - Talisman Southeast Journey's Boarding School Zirconia NC**

June 2007 – Aug. 2010

- Provided differential instruction to Middle and High school students of varying
- grade/ability levels with Aspergers, ADHD and ADD disorders.
- Collaborated with parents, staff and administration to ensure that all student
- needs and state standards were being met.

#### **Special Ed Teacher – E.L. DeGoyer Elementary Dallas, Texas**

Dec. 2002 – June 2007

Taught in a specialized unit for children with autism.

- Attended teacher in service and staff meetings
- Maintained professional relationship with staff and administrators
- Participated in school conferences representing my campus both locally and out of state
- Provided additional strategies for autistic children and their families, through individual needs planning
- Served as campus liaison for the Special Ed department
- Volunteered for the Special Olympics in which my students participated.

### Education

#### **Texas Wesleyan University, Fort Worth Texas**

- B.S. in law (paralegal)
- Tarrant County Alternative Teaching Program

**Educator Ecommerce Transactions**

Educator Identification:

SSN: 367-78-8605 First Name: Christina Last Name: David

**E-Commerce Transactions**  
Click on the date to view the details for the transaction.

Date/Time	Total Amount	Payment Type	Result	Refund**	Chargeback**
<a href="#">3/12/2012 10:34:37 AM</a>	\$40.00	CC-VISA-2187	Approved		

\*\*If Marked Refunded or Chargeback it may be partial or the whole transaction.

## Edward Daniel Coleman

202 Holcombe Cove Road, Candler, NC 28715

(828) 450-5065

blumtnmath87@gmail.com

- Objective** Teaching mathematics and 21<sup>st</sup> century learning skills to students in an exceptional Western North Carolina school.
- Experience**
- PRTF Math Teacher  
1/10/11 - Present Eliada Homes, Inc. Asheville, NC
- Provide differentiated instruction to adolescent students of varying grade/ability levels with mental health special needs in a locked treatment facility
  - Collaborate with students, program managers, case managers and other PRTF staff to ensure academic as well as therapeutic progress for each client
  - Established the Eliada Choir and currently serve as Music Director for the Choir.
- Private Tutor/Instructor  
10/15/10 – Present Asheville Learning, Inc. Asheville, NC
- Create individualized, differentiated lessons and remediation for students in a private, one-on-one setting
  - Helped several students to achieve great degrees of success in courses ranging from Algebra I to AP Calculus
  - Assess students' learning style, individual intelligences and personality profile to structure curriculum to best motivate students and suit their needs
- Education** University of North Carolina at Asheville, Asheville, NC  
August 2005 – May 2009
- B.A. in Mathematics with 9-12 Teacher Licensure
  - Student taught at Erwin High School for 5 months
  - North Carolina Teaching Fellow
  - Magna Cum Laude graduate with University and Department Honors Distinction
- Professional Interests** Exceptional children; cognitive neuroscience and theories of learning; sustainability and "green" culture; science and technology development; music; mathematical modeling; applied mathematics (game theory, dynamical systems)
- References** References are available on request.

STATE OF NORTH CAROLINA  
STATE BOARD OF EDUCATION • DEPARTMENT OF PUBLIC INSTRUCTION



License



DATE ISSUED  
06/10/2009  
RENEWAL CYCLE

EDWARD DAVIDL COLEMAN  
XXX-XX-9307

DATE EFFECTIVE  
07/01/2009  
DATE EXPIRES

06/06/2009 TO 06/06/2009  
THE PERSON NAMED HERE HAS COMPLETED A PROGRAM OF PREPARATION APPROVED BY THE STATE BOARD OF EDUCATION AND IS AWARDED THIS LICENSE TO SERVE IN THE SCHOOLS OF NORTH CAROLINA IN THE AREA(S) INDICATED. THIS LICENSE HAS BEEN ISSUED IN ACCORDANCE WITH STATE BOARD OF EDUCATION REGULATIONS

8805

PROGRAM CODE/STATUS	HQ CODE	CODE/AREA	CLASS CODE	EXP.
01 STANDARD PROFESSIONAL I	99	00209 MATHEMATICS (GRADES 9-12)	A	09

Class Codes:  
V Non-Degree  
A Bachelor's level  
M Master's  
S, AP, AS Sixth-year level  
D, DP, DS Doctorate level

Highly Qualified (HQ) status indicators, pursuant to PL107-110 (NCLB Act of 2001):  
 99 - Not Highly Qualified  
 98 - Not Applicable for Non-Core Academic Areas  
 97 - Highly Qualified not determined  
 96 - Highly Qualified based on undergraduate academic major  
 88 - Highly Qualified based on coursework equivalent to an undergraduate major  
 87 - Highly Qualified based on NC licensing test(s)  
 86 - Highly Qualified based on Other State licensing test(s)  
 85 - Highly Qualified based on a graduate degree  
 84 - Highly Qualified based on master's level licensure or above  
 83 - Highly Qualified based on NBPTS  
 82 - Highly Qualified based on NC HOUSE standard  
 81 - Highly Qualified based on Other State HOUSE standard

EACH LICENSE HOLDER IS RESPONSIBLE FOR KNOWING AND SATISFYING LICENSE RENEWAL REQUIREMENTS AND/OR ANY IDENTIFIED PROVISIONS OR DEFICIENCIES REQUIRED TO REISSUE HIS OR HER LICENSE

*Jane St. Clair Ottman*  
SUPERINTENDENT OF PUBLIC INSTRUCTION

STATE BOARD OF EDUCATION  
DEPARTMENT OF PUBLIC INSTRUCTION  
6365 MAIL SERVICE CENTER  
RALEIGH, NORTH CAROLINA 27635-6365

**Alice Owen**  
126 Woodcreek Circle  
Swannanoa  
NC 28778

Phone: (828) 686 1413 (Home) (828) 545 8523 (Cell)

**College Education:** Jordanhill College of Education, University of Glasgow, Glasgow, Scotland. (1984-88)

**Professional Qualifications:** Bachelor of Education (Elementary - Pre-school through 7<sup>th</sup> Grade)

Awarded Merit in teaching. Degree conferred: June 1988. Qualified Mental Health Professional.

N.C Teaching License (Elementary)

**Philosophy:** I believe that students learn best when they are in a structured environment. I set high standards for my students and they understand this expectation. I establish a classroom setting where students feel safe enough to take risks. I treat each student as an individual and meet them where they are.

**Recent Training:** First Aid, CPR; Therapeutic Crisis Intervention; Autism Spectrum Disorders; Classroom Strategies for Students with Asperger's Syndrome; Aggression Replacement Techniques, Balanced Literacy; Using Mac's and iPod Touch in the classroom; Positive Behavior Support; Person Centered Thinking, Overview of Public Education (3 semester hours), Common Core State Standards – Language Arts

**Teaching Experience:**

**January 2005-Current**

English Teacher, Eliada Academy, Asheville, NC. (Lead Teacher since August 2008)

- Created a policy to adopt a whole school approach to writing across the curriculum. Researched effective methods, developed sample lesson plans, and trained teachers in the approach.
- Mentored new teachers - provided materials, reviewed lessons, enabled them to observe in my class
- Implemented use of Brain Gym and Alpha Smarts in class and trained other staff in techniques
- Created warm-up activities for the team to use as part of the School Improvement Plan
- Assisted with successful accreditation process through Southern Association of Colleges and Schools (SACS)/AdvancEd.

**August 2002-January 2005**

Pre-school Teacher, Child Care Center of First Presbyterian Church, Asheville, NC.

**August 1999-June 2001**

4<sup>th</sup> Grade Teacher, Echline Primary School, South Queensferry, Scotland.

**August 1991-June 1999**

Taught 4<sup>th</sup> -6<sup>th</sup> Grade, Ullapool Primary School, Ullapool, Scotland.

**August 1988-June 1991**

Taught 2<sup>nd</sup> and 3<sup>rd</sup> Grade, Back Primary, Back, Isle of Lewis, Scotland.

STATE OF NORTH CAROLINA  
STATE BOARD OF EDUCATION • DEPARTMENT OF PUBLIC INSTRUCTION



# Professional Educator's License

DATE ISSUED

05/24/2011

RENEWAL CYCLE

ALICE MACHILLAN OWEN

DATE EFFECTIVE

07/01/2010

DATE EXPIRES

00/00/0000 TO 00/00/0000

06/30/2013

THE PERSON NAMED HAS COMPLETED A PROGRAM OF PREPARATION APPROVED BY THE STATE BOARD OF EDUCATION AND IS AWARDED THIS LICENSE TO SERVE IN THE SCHOOLS OF NORTH CAROLINA IN THE AREA(S) INDICATED. THIS LICENSE HAS BEEN ISSUED IN ACCORDANCE WITH STATE BOARD OF EDUCATION REGULATIONS

PROGRAM CODE/STATUS	HQ CODE	CODE/AREA	CLASS CODE	EXP.
52 STANDARD PROFESSIONAL I	87	00025 ELEMENTARY EDUCATION (GRADES K-5)	A	18

**Class Codes:**  
 V - Non-Degree level  
 A - Bachelor's level  
 M - Master's level  
 S, AP, AS, - Sixth-year level  
 D, DF, DS - Doctorate level

Highly Qualified (HQ) status indicators, pursuant to PL 107-110 (NCLB Act of 2001):  
 99 - Not Highly Qualified  
 98 - Not Applicable for Non-Core Academic Areas  
 97 - Highly Qualified not determined  
 89 - Highly Qualified based on undergraduate academic major  
 88 - Highly Qualified based on coursework equivalent to an undergraduate major  
 87 - Highly Qualified based on NC licensing test(s)

86 - Highly Qualified based on Other State licensing test(s)  
 85 - Highly Qualified based on a graduate degree  
 84 - Highly Qualified based on master's level licensure or above  
 83 - Highly Qualified based on NBFTS  
 82 - Highly Qualified based on NC HOUSSSE standard  
 81 - Highly Qualified based on Other State HOUSSSE standard  
 80 - Highly Qualified based on Other State's verification

EACH LICENSE HOLDER IS RESPONSIBLE FOR KNOWING AND SATISFYING LICENSE RENEWAL REQUIREMENTS AND/OR ANY IDENTIFIED PROVISIONS OR DEFICIENCIES REQUIRED TO REISSUE HIS OR HER LICENSE.

*Jane St. Clair Atkinson*  
 SUPERINTENDENT OF PUBLIC INSTRUCTION

STATE BOARD OF EDUCATION  
 DEPARTMENT OF PUBLIC INSTRUCTION  
 6365 MAIL SERVICE CENTER  
 RALEIGH, NORTH CAROLINA 27689-6365



**BACKGROUND INFORMATION**

Examinee's Name: OWEN, ALICE Candidate ID Number: 05065631  
 Social Security Number: [REDACTED] Sex: F Date of Birth: 04/01/1966

**EDUCATIONAL INFORMATION**

College Where Relevant Training Was Received: (I)  
 Undergraduate Major: ELEMENTARY EDUCATION  
 Graduate Major: (I)  
 Educational Level: EARNED BACHELOR'S DEGREE  
 GPA: 3.5 - 4.0

**SCORE RECIPIENT(S) REQUESTED**

Code #	Recipient Name
R7846(A)	NC DIV OF TEACHER ED SERVICES

CURRENT TEST DATE: 02/20/2010		Your Score	Possible Score Range	Average Performance Range**	Score Recipient Code(s) from Current Administration			
Test Name	Code #				R7846			
5710 C-PPST: READING		183	150-190	173-181	Y			
5720 C-PPST: WRITING		183	150-190	173-178	Y			
5730 C-PPST: MATHEMATICS		175	150-190	174-183	Y			

HIGHEST SCORE AS OF: 03/05/2010		Your Highest Score	Possible Score Range	Score Recipient Code(s)			
Test Name	Code #			R7846			
02/20/2010 5710 C-PPST: READING		183	150-190	Y			
02/20/2010 5720 C-PPST: WRITING		183	150-190	Y			
02/20/2010 5730 C-PPST: MATHEMATICS		175	150-190	Y			

ETS will retain your score for ten years for reporting purposes.  
 \*\* For more details on Average Performance Range refer to footnote on last page of this score report.  
 Message Codes: I = INFORMATION NOT PROVIDED OR INCORRECTLY GUIDED.  
 A = SCORE AUTOMATICALLY REPORTED TO STATE LICENSING AGENCY.  
 Y = SCORE REPORTED TO RECIPIENT LISTED.

TEST TAKER: OWEN, ALICE

**PASSED/NOT PASSED INFORMATION BASED ON HIGHEST SCORES EARNED AS OF: 03/05/2010**

Passed/not passed status provided in this report is based on the passing score in effect on the test date or on the date reported (as indicated next to each score recipient's name). Agencies reserve the right to accept the reporting of scores but not necessarily the passed/not passed status.

NC DIV OF TEACHER ED SERVICES			7846	Your Highest Score	Required Minimum Score	Minimum Score Met/Not Met	Required Passing Score	Passed/Not Passed Status
02/20/2010	5710	C-PPST: READING		183			176	PASSED
02/20/2010	5720	C-PPST: WRITING		183			173	PASSED
02/20/2010	5730	C-PPST: MATHEMATICS		175			173	PASSED

For more information on interpreting your scores, please refer to "Understanding Your Praxis Scores" available at [www.ets.org/praxis](http://www.ets.org/praxis). Further information on state requirements is also available online. Passed/Not Passed information not provided if more than one qualifying score is used for a test, or qualifying score is not available.

\*THIS INFORMATION IS PROVIDED TO THE EXAMINEE ONLY.  
 +PASSED/NOT PASSED INFORMATION NOT PROVIDED BECAUSE TEST(S) TAKEN IS/ARE NOT USED BY THIS AGENCY.

DETAILED INFORMATION FOR: 02/20/2010 TEST DATE

<b>COMPUTERIZED PRE-PROFESSIONAL SKILLS TEST: READING</b> I. CRITICAL AND INFERENTIAL COMPREHENSION II. LITERAL COMPREHENSION	19 17	22 18	12-19 12-17
<b>COMPUTERIZED PRE-PROFESSIONAL SKILLS TEST: WRITING</b> I. GRAMMATICAL RELATIONSHIPS II. STRUCTURAL RELATIONSHIPS III. WORD CHOICES AND MECHANICS IV. ESSAY	11 12 8 10	12 14 12 12	7-10 7-11 6-9 6-8
<b>COMPUTERIZED PRE-PROFESSIONAL SKILLS TEST: MATHEMATICS</b> I. NUMBER AND OPERATIONS II. ALGEBRA III. GEOMETRY AND MEASUREMENT IV. DATA ANALYSIS AND PROBABILITY	7 4 6 9	13 8 9 10	7-11 4-7 4-8 6-9

\* Category-level information indicates the number of test questions answered correctly for relatively small subsets of the questions. Because they are based on small numbers of questions, category scores are less reliable than the official scaled scores, which are based on the full set of questions. Furthermore, the questions in a category may vary in difficulty from one test form to another. Therefore, the category scores of individuals who have taken different forms of the test are not necessarily comparable. For these reasons, category scores should not be considered a precise reflection of a candidate's level of knowledge in that category and ETS recommends that category information not be used to inform any decisions affecting candidates without careful consideration of such inherent lack of precision.

\*\* The range of scores earned by the middle 50% of a group of examinees who took this form of the test at the most recent national administration or other comparable time period. N/C means that this range was not computed because fewer than 30 examinees took this form of the test or because there were fewer than 8 questions in the category or, for a constructed-response module, fewer than 8 points to be awarded by the raters. N/A indicates that this test section was not taken and, therefore, the information is not applicable.

Copyright © 2008 by Educational Testing Service. All rights reserved. ETS and the ETS logo are registered trademarks of Educational Testing Service.



THE PRAXIS SERIES is a trademark of ETS.



# THE PRAXIS SERIES™

## BACKGROUND INFORMATION

Examinee's Name: OWEN, ALICE

Candidate ID Number: 05065631

Social Security Number: [REDACTED]

Sex: F

Date of Birth: 04/01/1966

## EDUCATIONAL INFORMATION

College Where Relevant Training Was Received: (I)

Undergraduate Major: ELEMENTARY EDUCATION

Graduate Major: (I)

Educational Level: EARNED BACHELOR'S DEGREE

GPA: 3.5 - 4.0

## SCORE RECIPIENT(S) REQUESTED

Code #	Recipient Name
R7846(A)	NC DIV OF TEACHER ED SERVICES

## CURRENT TEST DATE: 04/24/2010

Test Name	Your Score	Average Range	Performance Range	Score Reported to Recipient (Current Administration)
0011 ELEM ED CURR INSTRUC ASSESSMENT	189	100-200	168-185	Y

## HIGHEST SCORE AS OF: 05/14/2010

Test Name	Your Highest Score	Possible Score Range	Score Reported to Recipient
04/24/2010 0011 ELEM ED CURR INSTRUC ASSESSMENT	189	100-200	Y
02/20/2010 5710 C-PPST: READING	183	150-190	Y
02/20/2010 5720 C-PPST: WRITING	183	150-190	Y
02/20/2010 5730 C-PPST: MATHEMATICS	175	150-190	Y

ETS will retain your score for ten years for reporting purposes.  
 \*\* For more details on Average Performance Range refer to footnote on last page of this score report.  
 Message Codes: I = INFORMATION NOT PROVIDED OR INCORRECTLY GRIDDED.  
 A = SCORE AUTOMATICALLY REPORTED TO STATE LICENSING AGENCY.  
 Y = SCORE REPORTED TO RECIPIENT LISTED.





**THE PRAXIS**  
S E R I E S™

TEST TAKER: OWEN, ALICE

**PASSED/NOT PASSED INFORMATION BASED ON HIGHEST SCORES EARNED AS OF: 05/14/2010**

Passed/not passed status provided in this report is based on the passing score in effect on the test date or on the date reported (as indicated next to each score recipient's name). Agencies reserve the right to accept the reporting of scores but not necessarily the passed/not passed status.

NC DIV OF TEACHER ED SERVICES			7846	Your Highest Score	Required Minimum Score	Minimum Score Met/Not Met	Required Passing Score	Passed/Not Passed Status
02/20/2010	5710	C-PPST: READING		183			176	PASSED
02/20/2010	5720	C-PPST: WRITING		183			173	PASSED
02/20/2010	5730	C-PPST: MATHEMATICS		175			173	PASSED
04/24/2010	0011	ELEM ED CURR INSTRUC ASSESSMENT		189				

For more information on interpreting your scores, please refer to "Understanding Your Praxis Scores" available at [www.ets.org/praxis](http://www.ets.org/praxis). Further information on state requirements is also available online. Passed/Not Passed information not provided if more than one qualifying score is used for a test, or qualifying score is not available.

\*THIS INFORMATION IS PROVIDED TO THE EXAMINEE ONLY.

+PASSED/NOT PASSED INFORMATION NOT PROVIDED BECAUSE TEST(S) TAKEN IS/ARE NOT USED BY THIS AGENCY.



DETAILED INFORMATION FOR: 04/24/2010 TEST DATE

ELEMENTARY EDUCATION: CURRICULUM, INSTRUCTION, AND ASSESSMENT

I. READING AND LANGUAGE ARTS CURRICULUM, INSTRUCTION, AND ASSESSMENT	32	38	25- 30
II. MATHEMATICS CURRICULUM, INSTRUCTION, AND ASSESSMENT	18	21	14- 18
III. SCIENCE CURRICULUM, INSTRUCTION, AND ASSESSMENT	11	12	8- 11
IV. SOCIAL STUDIES CURRICULUM, INSTRUCTION, AND ASSESSMENT	9	12	8- 10
V. ARTS AND PHYSICAL EDUCATION CURRICULUM, INSTRUCTION, AND ASSESSMENT	10	11	8- 10
VI. GENERAL INFORMATION ABOUT CURRICULUM, INSTRUCTION, AND ASSESSMENT	13	16	11- 13

\* Category-level information indicates the number of test questions answered correctly for relatively small subsets of the questions. Because they are based on small numbers of questions, category scores are less reliable than the official scaled scores, which are based on the full set of questions. Furthermore, the questions in a category may vary in difficulty from one test form to another. Therefore, the category scores of individuals who have taken different forms of the test are not necessarily comparable. For these reasons, category scores should not be considered a precise reflection of a candidate's level of knowledge in that category and ETS recommends that category information not be used to inform any decisions affecting candidates without careful consideration of such inherent lack of precision.

\*\* The range of scores earned by the middle 50% of a group of examinees who took this form of the test at the most recent national administration or other comparable time period. N/C means that this range was not computed because fewer than 30 examinees took this form of the test or because there were fewer than 8 questions in the category or, for a constructed-response module, fewer than 8 points to be awarded by the raters. N/A indicates that this test section was not taken and, therefore, the information is not applicable.

Copyright © 2008 by Educational Testing Service. All rights reserved. ETS and the ETS logo are registered trademarks of Educational Testing Service.

 THE PRAXIS SERIES is a trademark of ETS.

09065031\_04242010\_03042010154826050758



**THE PRAXIS**  
S E R I E S™



**BACKGROUND INFORMATION**

Examinee's Name: OWEN, ALICE Candidate ID Number: 05065631  
 Social Security Number: [REDACTED] Sex: F Date of Birth: 04/01/1966

**EDUCATIONAL INFORMATION**

College Where Relevant Training Was Received: (I)  
 Undergraduate Major: ELEMENTARY EDUCATION  
 Graduate Major: (I)  
 Educational Level: EARNED BACHELOR'S DEGREE  
 GPA: 3.5 - 4.0

**SCORE RECIPIENT(S) REQUESTED**

Code #	Recipient Name
R7846(A)	NC DIV OF TEACHER ED SERVICES

CURRENT TEST DATE: 04/24/2010		Your Score	Possible Score Range	Average Performance Range	Score Recipient Code from Current Administration				
Code	Test Name				R7846				
0012	ELEM ED CONTENT AREA EXERCISES	176	100-200	151-163	Y				

HIGHEST SCORE AS OF: 05/21/2010		Your Highest Score	Possible Score Range	Score Recipient Code (N)					
Date	Code	Test Name			R7846				
04/24/2010	0011	ELEM ED CURR INSTRUC ASSESSMENT	189	100-200	Y				
04/24/2010	0012	ELEM ED CONTENT AREA EXERCISES	176	100-200	Y				
02/20/2010	5710	C-PPST: READING	183	150-190	Y				
02/20/2010	5720	C-PPST: WRITING	183	150-190	Y				
02/20/2010	5730	C-PPST: MATHEMATICS	175	150-190	Y				

ETS will retain your score for ten years for reporting purposes.  
 \*\* For more details on Average Performance Range refer to footnote on last page of this score report.  
 Message Codes: I = INFORMATION NOT PROVIDED OR INCORRECTLY GRIDDED.  
 A = SCORE AUTOMATICALLY REPORTED TO STATE LICENSING AGENCY.  
 Y = SCORE REPORTED TO RECIPIENT LISTED.



**THE PRAXIS  
SERIES**

TEST TAKER: OWEN, ALICE

**PASSED/NOT PASSED INFORMATION BASED ON HIGHEST SCORES EARNED AS OF: 05/21/2010**

Passed/not passed status provided in this report is based on the passing score in effect on the test date or on the date reported (as indicated next to each score recipient's name). Agencies reserve the right to accept the reporting of scores but not necessarily the passed/not passed status.

NC DIV OF TEACHER ED SERVICES			7846	Your Highest Score	Required Minimum Score	Minimum Score Met/Not Met	Required Passing Score	Not Passed Status
02/20/2010	5710	C-PPST: READING		183			176	PASSED
02/20/2010	5720	C-PPST: WRITING		183			173	PASSED
02/20/2010	5730	C-PPST: MATHEMATICS		175			173	PASSED
04/24/2010	0011	ELEM ED CURR INSTRUC ASSESSMENT		189				
04/24/2010	0012	ELEM ED CONTENT AREA EXERCISES		176				
		TOTAL ELEM ED K-6 SCORE		385			313	PASSED

For more information on interpreting your scores, please refer to "Understanding Your Praxis Scores" available at [www.ets.org/praxis](http://www.ets.org/praxis). Further information on state requirements is also available online. Passed/Not Passed information not provided if more than one qualifying score is used for a test, or qualifying score is not available.

\*THIS INFORMATION IS PROVIDED TO THE EXAMINEE ONLY.

+PASSED/NOT PASSED INFORMATION NOT PROVIDED BECAUSE TEST(S) TAKEN IS/ARE NOT USED BY THIS AGENCY.





DETAILED INFORMATION FOR: 04/24/2010 TEST DATE

TEST CATEGORY	Points Earned	Points Available	Performance Range
ELEMENTARY EDUCATION: CONTENT AREA EXERCISES			
I. READING AND LANGUAGE ARTS	11	12	7- 9
II. MATHEMATICS	8	12	7- 9
III. SCIENCE/SOCIAL STUDIES	11	12	7- 9
IV. INTEGRATED CONTENT AREA	12	12	8- 9

\* Category-level information indicates the number of test questions answered correctly for relatively small subsets of the questions. Because they are based on small numbers of questions, category scores are less reliable than the official scaled scores, which are based on the full set of questions. Furthermore, the questions in a category may vary in difficulty from one test form to another. Therefore, the category scores of individuals who have taken different forms of the test are not necessarily comparable. For these reasons, category scores should not be considered a precise reflection of a candidate's level of knowledge in that category and ETS recommends that category information not be used to inform any decisions affecting candidates without careful consideration of such inherent lack of precision.

\*\* The range of scores earned by the middle 50% of a group of examinees who took this form of the test at the most recent national administration or other comparable time period. N/C means that this range was not computed because fewer than 30 examinees took this form of the test or because there were fewer than 8 questions in the category or, for a constructed-response module, fewer than 8 points to be awarded by the raters. N/A indicates that this test section was not taken and, therefore, the information is not applicable.

**Marisel Vicente Santiago**  
51 Kentwood Drive, Weaverville, NC 28787,  
(786) 280-0108, [lilysmama@rocketmail.com](mailto:lilysmama@rocketmail.com)

### **Bilingual Elementary Education Teacher**

Goal driven professional with a solid commitment to the social and academic growth of every student.

#### *Experience*

2012 to Present

Title One Teacher

Eliada Academy

- Oversee all BASI Testing for students within Eliada Homes.
- Maintain all BASI Testing records.
- Develop and implement lesson plans for Literacy class/tutoring.

2001 to 2012

Elementary Education Teacher

Miami-Dade County Public Schools

- ▲ Develop lesson plans to meet the academic, intellectual, and social needs of students.
- ▲ Enhance student academic and social growth by utilizing differentiated instruction.
- ▲ Continuous assessment of student performance to further accommodate and improve learning.

2000 to 2000

Reading Teacher

Dade Marine Institute

- ▲ Served as a teacher/mentor to students transitioning from the Florida Juvenile Justice System.
- ▲ Developed hands-on lesson plans that focused on student-driven success.
- ▲ Established and implemented classroom management system that focused on meeting goals.

1999 to 2000

Substitute

Miami-Dade County Public Schools

- ▲ Provided long and short term replacement of the permanent teacher.
- ▲ Actively engaged students in the learning process while implementing established lesson plans.
- ▲ Enhanced learning utilizing a multi-disciplinary approach.

#### *Education/Certification*

- ▲ Bachelor of Science - Elementary Education
- ▲ ESOL Endorsement K-12
- ▲ North Carolina Teaching License Elementary Education K-6
- ▲ Florida Teaching License Elementary Education 1-6
- ▲ On-going professional development in the areas of Reading, Writing, Math, Context, Technology, ESL, Child Abuse, and Character Education.

Nova Southeastern University

#### *Special Skills, Honors*

- ▲ Fluent in Spanish.
- ▲ Awarded Project Rise Grant 2011, 2012 for implementing best practices in reading.
- ▲ School-wide Teacher of the Year 2006.
- ▲ United Way Fund Raiser Chair 2003-2009.

STATE OF NORTH CAROLINA  
STATE BOARD OF EDUCATION • DEPARTMENT OF PUBLIC INSTRUCTION



# Professional Educator's License

DATE ISSUED

03/11/2011

RENEWAL CYCLE

MARISOL VICENTE SANTIAGO

XXX-XX-5742

DATE EFFECTIVE

03/11/2011

DATE EXPIRES

05/00/0000 TO 00/00/0000

THE PERSON NAMED HAS COMPLETED A PROGRAM OF PREPARATION APPROVED BY THE STATE BOARD OF EDUCATION AND IS AWARDED THIS LICENSE TO SERVE IN THE SCHOOLS OF NORTH CAROLINA IN THE AREA(S) INDICATED. THIS LICENSE HAS BEEN ISSUED IN ACCORDANCE WITH STATE BOARD OF EDUCATION REGULATIONS

PROGRAM CODE/STATUS	HQ CODE	CODE/AREA	CLASS CODE	EXP.
S4 STANDARD PROFESSIONAL I	86	00025 ELEMENTARY EDUCATION (GRADES K-6)	A	6

**Class Codes:**  
 V - Non-Degree level  
 A - Bachelor's level  
 M - Master's level  
 S, AP, AS, - Sixth-year level  
 D, DP, DS - Doctorate level

**Highly Qualified (HQ) status indicators, pursuant to PL 107-110 (NCLB Act of 2001):**  
 99 - Not Highly Qualified  
 98 - Not Applicable for Non-Core Academic Areas  
 97 - Highly Qualified not determined  
 89 - Highly Qualified based on undergraduate academic major  
 88 - Highly Qualified based on coursework equivalent to an undergraduate major  
 87 - Highly Qualified based on NC licensing test(s)

86 - Highly Qualified based on Other State licensing test(s)  
 85 - Highly Qualified based on a graduate degree  
 84 - Highly Qualified based on master's level licensure or above  
 83 - Highly Qualified based on NBPTS  
 82 - Highly Qualified based on NC HOUSE standard  
 81 - Highly Qualified based on Other State HOUSE standard  
 80 - Highly Qualified based on Other State's verification

EACH LICENSE HOLDER IS RESPONSIBLE FOR KNOWING AND SATISFYING LICENSE RENEWAL REQUIREMENTS AND/OR ANY IDENTIFIED PROVISIONS OR DEFICIENCIES REQUIRED TO REISSUE HIS OR HER LICENSE.

*Jane St. Clair Atkinson*  
 SUPERINTENDENT OF PUBLIC INSTRUCTION

STATE BOARD OF EDUCATION  
 DEPARTMENT OF PUBLIC INSTRUCTION  
 6365 MAIL SERVICE CENTER  
 RALEIGH, NORTH CAROLINA 27699-6365

# State of Florida Department of Education

## PROFESSIONAL EDUCATOR'S CERTIFICATE

*This Certifies That*

**MARISEL VICENTE SANTIAGO**

*Has satisfactorily completed all requirements of Florida Statutes and State Board of Education Rules for the coverages or endorsements listed below:*

ELEMENTARY EDUCATION / (GRADES 1 - 6)  
ENGLISH FOR SPEAKERS OF OTHER LANGUAGES (ESOL) / ENDORSEMENT

*July 01, 2009 - June 30, 2014*  
Department of Education Number 852845



**Dr. Frances Haithcock**  
Chancellor, K-12 Public Schools



**Dr. Eric J. Smith**  
Commissioner of Education

May 13, 2011

# Florida Teacher Certification Examinations — SCORE REPORT

Date: 02/09/01

FTCE-O These scores are for the original FTCE examination.			SUBJECT AREA EXAMINATION (SAE) SCORE	
FTCE Writing  NT	FTCE Reading  NT	FTCE Mathematics  NT	SAE TOTAL	PASS

01/20/01 ELEMENTARY ED. 1-6

Social Security No. 042-56-5742

VICENTE MARISEL  
 13775-3 SW 149 CIR LN  
 MIAMI FL 33186

PROFESSIONAL EDUCATION						COLLEGE-LEVEL ACADEMIC SKILLS TEST (CLAST)						
Prof. Ed.		Analysis by Content Base				SCALE SCORE	Arithmetic	Algebra	Geometry/Measurement	Logical Reasoning	Statistics	
PASS		1.	2.	3.	4.	5.	NT					
CLAST ENGLISH LANGUAGE SKILLS						CLAST READING			CLAST ESSAY			
SCALE SCORE	Grammar Spelling Punctuation Capitalization	Word Choice	Sentence Structure			SCALE SCORE	Literal	Comprehension	Critical	ESSAY RATING		
NT						NT				NT		

10/28/00

A discussion of the results is on the reverse side of this report. A number in a shaded box indicates a test not passed.

# Florida Teacher Certification Examinations — SCORE REPORT

Date: 11/17/00

FTCE-O These scores are for the original FTCE examination.			SUBJECT AREA EXAMINATION (SAE) SCORE	
FTCE Writing  NT	FTCE Reading  NT	FTCE Mathematics  NT	SAE TOTAL	NT

Social Security No. 042-56-5742

VICENTE MARISEL  
 13775-3 SW 149 CIR LN  
 MIAMI FL 33186

PROFESSIONAL EDUCATION						COLLEGE-LEVEL ACADEMIC SKILLS TEST (CLAST)						
Prof. Ed.		Analysis by Content Base				SCALE SCORE	Arithmetic	Algebra	Geometry/Measurement	Logical Reasoning	Statistics	
PASS		1.	2.	3.	4.	5.	NT					
CLAST ENGLISH LANGUAGE SKILLS						CLAST READING			CLAST ESSAY			
SCALE SCORE	Grammar Spelling Punctuation Capitalization	Word Choice	Sentence Structure			SCALE SCORE	Literal	Comprehension	Critical	ESSAY RATING		
NT						NT				NT		

10/28/00

A discussion of the results is on the reverse side of this report. A number in a shaded box indicates a test not passed.

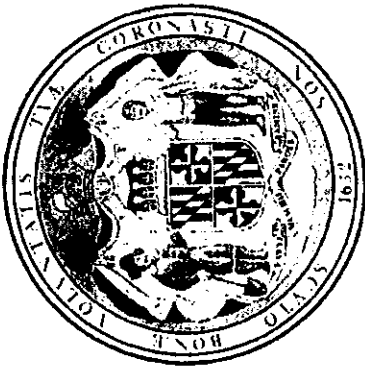

# MARYLAND EDUCATOR CERTIFICATE

## DEREK BRISCOE

*is issued this certificate on the basis of having met the legal requirements in the State of Maryland.*

EDUCATOR ID

3282

HIGHEST DEGREE

Bachelor's

TYPE

Conditional Degree Certificate

VALID

1/1/2011 - 12/31/2012

CERTIFICATION AREAS

Generic Special Education 6-Adult

ANCILLARY CREDITS

Reading 3

It is the responsibility of the holder of this certificate to know the current certification requirements and to renew this certificate prior to the expiration date.

Given at Baltimore, Maryland, by

State Superintendent of Schools

**Stephen Randall Shell, Jr.**

202 Brickton Village Circle  
Unit #101  
Fletcher NC, 28732  
828-337-3244  
stephen.shell@yahoo.com

**OBJECTIVE:** To employ my unique gifts and professional skills to help enrich the lives of students that I am fortunate enough to work with.

**QUALIFICATIONS**

- Licensed to teach English and Theatre Arts.
- Experienced in teaching honors, standard and inclusion level English classes.
- Worked to prepare students for both the End of Course exams and State Graduation Project.
- Uniquely gifted with at-risk and exceptional students.

**EDUCATION**

The University of Virginia's College at Wise: Double Major English Literature and Mass Communication. 1996-2002  
Mars Hill College: Certification to teach Theatre Arts. Summer 2006

**EMPLOYMENT**

8/2008- Present

**Eliada Academy/Eliada Homes, Inc.**

*Lead PRTF English Teacher/Therapeutic Performing Arts Teacher*

I currently work in the psychiatric residential treatment facilities at Eliada Homes in Asheville, North Carolina. I teach students with diagnosed behavioral disorders that live in a locked, residential setting. I have developed an academic English and therapeutic performing arts curriculum for residential students in grades 6-12. I have also developed a specialized, technology-based program focused on utilizing video and audio production in order to tailor instruction for individual students with specific behavioral and educational needs.

7/2004-7/2008

**Buncombe County Schools**

*English Teacher/Theatre Director*

Highly qualified English and Theatre Arts teacher at Enka High School in Candler, North Carolina. Taught English I, III and IV at the honors, standard and inclusion levels. Experienced team teacher and comfortable with collaborating with other departments in developing accommodations for students with specialized educational needs. Built and headed the theatre program at Enka High School and produced multiple award winning shows.

10/2003-6/2004

**Wise County Schools**

*Homebound Instructor/Tutor/Aid*

Tutored students classified as learning disabled, emotionally disturbed or potentially violent. Worked towards Standards of Learning Exam review as well as basic middle school curriculum. Worked with Wise County's special needs program to maintain contact with consistently absent students.

**Derek Briscoe**  
7935 Fairground Road, La Plata, MD 20646  
301-934-5369  
d\_briscoe@live.com

**Education:**

- Bachelor's Degree from Salisbury University
  - Majored in Philosophy, minored in English
  - Recipient of Philosophy Student of the Year Award for 2006-2007
- High School Diploma from Henry E. Lackey High School
  - 790 Math SAT, 760 Verbal SAT
- Continuing Education online

**Relevant Experience/Skills:**

- Teaching classes of up to 30 students, with and without disabilities
  - 6<sup>th</sup> to 9<sup>th</sup> grade inclusive class of 9, Physical Education elective of 6<sup>th</sup> to 12<sup>th</sup> graders
- Teaching students with a wide range of disabilities in one on one tutorial sessions
  - Assessing students and creating comprehensive Individual Education Plans
  - Working with students functioning well below "grade level" to access challenging curriculum
- Managing a classroom with students with emotional and behavioral issues
  - Keeping atmosphere light and engaging while maintaining keen awareness of students
  - Informally assessing students' understanding while keeping pace with curriculum demands
- Learning and implementing curriculum for 25 different courses taught in the past three years
  - Learning quickly and thoroughly, modifying to accommodate individual learning styles
- Certified Staff Trainer for Therapeutic Aggression Control Techniques-II Program
  - Able to remain collected under pressure, skilled in deescalation of potential emotional crises
  - Extremely patient, understanding and agreeable with even the most difficult personalities
- Working one on one in the community assisting children and adults with developmental disabilities with daily living tasks and with learning new skills
- Teaching groups of children and adults Tae Kwon Do
- Small group and one on one tutoring of K-12 students in all subjects

**Relevant Work History:**

1-09 to present Certified Special Education Teacher at High Road School of Southern Maryland  
11-08 to 7-09 SAT Prep Class Teacher for Kaplan  
7-08 to 11-08 Direct Care Educator for Easter Seals UCP  
11-99 to 9-03 Certified Instructor at Southern Maryland Martial Arts Academy  
9-00 to 6-03 Tutor for College of Southern Maryland





STATE OF NORTH CAROLINA  
STATE BOARD OF EDUCATION • DEPARTMENT OF PUBLIC INSTRUCTION



License



DATE ISSUED  
07/05/2007  
RENEWAL CYCLE

STEPHEN RANDALL SHELL  
XXX-XX-7740

DATE EFFECTIVE  
07/01/2007  
DATE EXPIRES

07/01/2007 TO 06/30/2012  
THE PERSON NAMED HERE HAS COMPLETED A PROGRAM OF PREPARATION APPROVED BY THE STATE BOARD OF EDUCATION AND IS AWARDED THIS LICENSE TO SERVE IN THE SCHOOLS OF NORTH CAROLINA IN THE AREA(S) INDICATED. THIS LICENSE HAS BEEN ISSUED IN ACCORDANCE WITH STATE BOARD OF EDUCATION REGULATIONS

PROGRAM CODE/STATUS	HQ CODE	CODE/AREA	CLASS CODE	EXP
01 STANDARD PROFESSIONAL II	00	00100 ENGLISH (GRADES 9-12)	A	3
02 STANDARD PROFESSIONAL II	00	00108 THEATER ARTS (GRADES K-12)	A	3

Class Codes:  
V Non-Degree  
A Bachelor's level  
M Master's  
S, AP, AS Sixth-year level  
D, DP, DS Doctorate level

Highly Qualified (HQ) status indicators, pursuant to PL107-110 (NCLB Act of 2001):  
99 - Not Highly Qualified  
98 - Not Applicable for Non-Core Academic Areas  
97 - Highly Qualified not determined  
89 - Highly Qualified based on undergraduate academic major  
88 - Highly Qualified based on coursework equivalent to an undergraduate major  
87 - Highly Qualified based on NC licensing test(s)

86 - Highly Qualified based on Other State licensing test(s)  
85 - Highly Qualified based on a graduate degree  
84 - Highly Qualified based on master's level licensure or above  
83 - Highly Qualified based on NBPTS  
82 - Highly Qualified based on NC HOUSE standard  
81 - Highly Qualified based on Other State HOUSE standard

EACH LICENSE HOLDER IS RESPONSIBLE FOR KNOWING AND SATISFYING LICENSE RENEWAL REQUIREMENTS AND/OR ANY IDENTIFIED PROVISIONS OR DEFICIENCIES REQUIRED TO REISSUE HIS OR HER LICENSE

*Shirley St. Clair Atkinson*

STATE BOARD OF EDUCATION  
DEPARTMENT OF PUBLIC INSTRUCTION  
6365 MAIL SERVICE CENTER

**Rena Overby Bacon**  
 828.505.1817 or 828.989.0546  
 rbeducator@yahoo.com

Highly motivated Professional Educator recognized for exceeding system goals, effectively communicating mission, vision, and purpose, developing solid and professional relations through extraordinary interpersonal and team-building skills.

**CORE STRENGTHS**

- |  |  |
|--|--|
| <ul style="list-style-type: none"> <li>▪ Excellent Rapport with Diverse Populations</li> <li>▪ Core Leadership Roles</li> <li>▪ Parent/Teacher Relations</li> <li>▪ New Student Orientations</li> <li>▪ Student Relations</li> <li>▪ High Attention to Detail</li> </ul> | <ul style="list-style-type: none"> <li>▪ Student Teacher Supervisor</li> <li>▪ IILT Mentor</li> <li>▪ Athletic Coach</li> <li>▪ Curriculum Development</li> <li>▪ Extensive Professional Development</li> <li>▪ Efficient Multi-Tasking</li> </ul> |
|--|--|

**PROFESSIONAL EXPERIENCE**

- |   |                       |
|---|-----------------------|
| <p>StatWorks, Inc, Research Triangle Park, NC<br/> <b>Data Entry Associate</b></p>  | <p>2008 - Current</p> |
| <p>Chewning Middle School<br/>         Durham Public Schools, Durham, NC<br/> <b>8th Grade English/Language Arts Teacher</b></p>  | <p>2007 - 2009</p>    |
| <p>Cane Creek Middle School<br/>         Buncombe County Schools, Fletcher, NC<br/> <b>7th Grade English/Language Arts Teacher</b></p>  | <p>2005 - 2007</p>    |
| <p>West Craven Middle School<br/>         Craven County Schools, New Bern, NC<br/> <b>6th - 8th Reading Remediation Teacher</b><br/> <b>6th Grade English/Language Arts Teacher</b></p>   | <p>2003 - 2005</p>    |
| <p>Berkeley Middle School<br/>         Williamsburg-James City County Schools, Williamsburg, VA<br/> <b>8th Grade English Teacher</b><br/> <b>7th Grade Reading Teacher</b><br/> <b>6th Grade Math Teacher A-VID Team</b><br/> <b>6th Grade English/Language Arts Teacher</b></p> | <p>1999 - 2002</p>    |
| <p>Grover C. Fields Middle School<br/>         Craven County Schools, New Bern, NC<br/> <b>6th Grade English/ Language Arts Teacher</b><br/> <b>6th Grade Social Studies Teacher</b></p>  | <p>1994 - 1999</p>    |
| <p>Asheville High School<br/>         Asheville City Schools, Asheville, NC<br/> <b>9th Grade English Teacher</b></p>   | <p>1994</p>           |

## **EDUCATION**

**Mars Hill College, Mars Hill, NC**  
Music Education

**University of North Carolina, Asheville, NC**  
B. A. Psychology  
K-12 Reading

**University of North Carolina, Asheville, NC**  
K-12 Reading Certification

**East Carolina University, Greenville, NC**  
6-9 English/Language Arts Certification

**Processology Institute, Cary, NC**  
Certified Processologist

## **PROFESSIONAL DEVELOPMENT**

- 1 Connie Prevatte Literacy Model
- 2 Empowering Writers: Expository and Argumentative
- 3 Mentor Teacher Training
- 4 Facilitative Leadership Training
- 5 David Langford Institute Quality Leadership Training
- 6 NCMSA Conference Presenter
- 7 VMSA Conference Presenter
- 8 A-VID Summer Institute
- 9 National Middle School Conference participant

## **PROFESSIONAL SERVICE**

- 1 Leadership Team Durham Public Schools
- 2 Superintendent's Committee Williamsburg-James City County Schools
- 3 Staff Development Committee Chair Craven County Schools
- 4 Team Leader Craven County Schools
- 5 School Leadership Craven County Schools
- 6 Cheerleading Coach
- 7 Drama Coach
- 8 Softball Coach

**References furnished upon request**



STATE OF NORTH CAROLINA  
 STATE BOARD OF EDUCATION • DEPARTMENT OF PUBLIC INSTRUCTION  
**Professional Educator's License**



DATE ISSUED  
 02/17/13  
 RENEWAL CYCLE

XXXX XXXX OVERSEAS ACTION  
 XXX-XX-6521

DATE EFFECTIVE  
 07/22/2007  
 DATE EXPIRES

THE PERSON NAMED HAS COMPLETED A PROGRAM OF PREPARATION APPROVED BY THE STATE BOARD OF EDUCATION AND IS AWARDED THIS LICENSE TO SERVE IN THE SCHOOLS OF NORTH CAROLINA IN THE AREAS(S) INDICATED. THIS LICENSE HAS BEEN ISSUED IN ACCORDANCE WITH STATE BOARD OF EDUCATION REGULATIONS

PROGRAM CODE/STATUS	HO CODE	CODE/AREA	CLASS CODE	EXR
97 - STATEMENT PROFESSIONAL II	98	00190 - READING (GRADES K-12)		14
92 - STATEMENT PROFESSIONAL II	97	74100 - MIDDLE GRADE SCIENCE (6-8)		14

Class Codes:  
 V Non-Degree level  
 A Bachelor's level  
 M Master's level  
 S, AP, AS, Sixth-year level  
 D, DP, DS Doctorate level

Highly Qualified (HQ) status indicators, pursuant to PL 107-110 (NCLB Act of 2001):  
 99 - Not Highly Qualified  
 98 - Not Applicable for Non-Core Academic Areas  
 97 - Highly Qualified not determined  
 89 - Highly Qualified based on undergraduate academic major  
 88 - Highly Qualified based on coursework equivalent to an undergraduate major  
 87 - Highly Qualified based on NC licensing tests)

86 - Highly Qualified based on Other State licensing test(s)  
 85 - Highly Qualified based on a graduate degree  
 84 - Highly Qualified based on master's level licensure or above  
 83 - Highly Qualified based on NIBPTS  
 82 - Highly Qualified based on NC HOUSE standard  
 81 - Highly Qualified based on Other State HOUSE standard  
 80 - Highly Qualified based on Other State's verification

EACH LICENSE HOLDER IS RESPONSIBLE FOR KNOWING AND SATISFYING LICENSE RENEWAL REQUIREMENTS AND/OR ANY IDENTIFIED PROVISIONS OR DEFICIENCIES REQUIRED TO REISSUE HIS OR HER LICENSE.

*Jane St. Clair Atkinson*  
 SUPERINTENDENT OF PUBLIC INSTRUCTION

STATE BOARD OF EDUCATION  
 DEPARTMENT OF PUBLIC INSTRUCTION  
 6365 MAIL SERVICE CENTER  
 RALEIGH, NORTH CAROLINA 27699-6365

## Position Description

**Job Title:** Eliada Academy Director  
**Department:** Eliada Academy  
**Status:** Professional/Exempt

**Salary Grade:**

### Position Summary:

Under the direction of the Chief Operations Officer, the Eliada Academy Director is responsible for the development, implementation and service delivery of Eliada Academy and Day Treatment services.

### Major Responsibilities:

1. Academic/Service Delivery: Actively develops, implements and manages quality Charter School and Day Treatment Programs and delivery of academic and treatment services to students with mental health diagnosis.
  - a. Oversees a quality program of academic instruction and student learning.
  - b. Coordinates service delivery with case management, intake, clinical and other support services at the agency and in the community.
  - c. Participates in the ongoing development, implementation and evaluation of treatment/behavioral interventions and activities. Participates in the agency's evaluation and outcomes plan.
  - d. Ensures compliance with charter school, licensure, accreditation and agency standards and policies.
2. Supervises and manages staff assigned to Director's direct supervision.
  - a. Initiates weekly supervision, disciplinary action and performance evaluation of academic and treatment staff
  - b. Recommends the hiring of qualified Eliada Academy and treatment staff.
  - c. Provides supervision to QPs, APs and PPs according to NCAC and licensing guidelines.
  - d. Participates in the development and implementation of training and professional development for academic and treatment staff and for portions of pre-service training for all newly hired staff.
  - e. Ensures appropriate and adequate staff coverage at all times, maintaining 1: 6 QP and 1:4 staff to client ratios in the program.
3. Functions as liaison for Eliada Academy and Day Treatment Programs.
  - a. Develops and maintains relationships with community organizations, referral agencies, students/families and other members of the community.
  - b. Participates in leadership team for agency's education and treatment services. Includes shared oversight of agency's quality management, program development and evaluation; and clinical/best practices of care.
4. Participates in the preparation of budgets assigned to service areas.
  - a. Ensures monitoring and adherence to annual budgets.
5. Provides crisis management support and service delivery, including shared on call crisis services.

### Other Responsibilities:

1. Ensures the provision of quality services to students through participation in the agency's CQI processes.
2. Displays competence and responsiveness to cultural differences present in both student and employee population.
3. Performs other related administrative and management tasks as assigned by the Chief Operations Officer.

### Reporting Relationship:

Position reports to: Chief Operations Officer

Position supervises: Teachers, Program Manager, Case Managers, Administrative Assistant and Day Treatment staff.

### Qualifications:

#### Knowledge:

- A Master's degree in Education or related Human Services field from an accredited college or university. Must meet requirements and standards for a Qualified Professional.
- Requires knowledge of service delivery and behavioral management in social and behavioral health services.

#### Experience:

- Five or more years experience in the delivery of education and behavioral/mental health services.
- Two or more years supervisory experience.

**Skills:** Must possess a valid NC driver's license and insurability by the agency's insurers. This position requires on-call responsibilities. Requires ability to implement restrictive interventions. Position may experience verbal and physical aggression from the client population.

### Disclaimer Clause

Job descriptions are not intended, and should not be construed, to be exhaustive lists of all responsibilities, skills, efforts or working conditions associated with this job. They are meant to be accurate reflections of the principal job elements essential for making fair pay decisions. This position description is not intended as a contract. A Letter of Employment confirms employment. North Carolina is an at-will employment state and Eliada is an at-will employer.

4/2012

## Position Description

**Job Title:** Teacher  
**Department:** Eliada Academy  
**Status:** Professional/Exempt

**Salary Grade:**

### Position Summary:

Under the supervision of the Eliada Academy Director, the Teacher will develop and implement curricula designed in accordance with the NC Standard Course of Study in order to help students learn subject matter and skills that will contribute to their academic development.

### Major Responsibilities:

1. Develop lessons for all students enrolled in the Eliada Academy in accordance with the NC Standard Course of Study, while differentiating for individual needs, various learning styles, and class dynamics. Completes weekly objective forms to document adherence to the curriculum.
2. Collaborates with the Treatment staff to provide behavioral supervision employing the Eliada Model in order to create a classroom environment that meets both the academic and treatment needs of the students. Ensures the safety of students by providing constant supervision and thoroughly and effectively using the agency's crisis intervention. Ability to perform physical restraint techniques as part of the agency's crisis intervention model.
3. Evaluates the academic progress of all students, which includes but is not limited to, preparing progress and grade reports by utilizing the computerized grading program, communicating academic progress to case managers, completing Student Education Plans and providing input for planning and implementing IEP goals and objectives.
4. Establishes and maintains a structures, safe and student-friendly classroom, which includes but is not limited to, active student engagement differentiation, clean and organized environment, clear and consistent procedures and expectations, and incorporation of school improvement components (i.e. school-wide writing approach, professional development, etc.) into instruction.
5. Obtains and maintains teaching certificate in accordance with North Carolina Department of Public Instruction (DPI) and participates in professional growth opportunities, such as county or state workshops, conferences, and/or advanced coursework at institutions of higher learning.

### Other Responsibilities:

1. Display competence and responsiveness to cultural differences present in both student and staff population.
2. Ensure the provision of quality services to students through participation in the agency's CQI process. Seeks opportunities to improve the academic program in relationship to their areas of expertise.
3. Actively participates and communicates with Eliada Academy team members on a consistent basis regarding academic strategies. Participates in scheduled teacher work days, all-staff agency meetings, as well as complying with all training requirements.
4. Develops appropriate educational field trips.
5. Ensure the safety of the students by providing consistent monitoring and supervision throughout the school.

### Reporting Relationship:

Position reports to: Eliada Academy Director

### Qualifications:

**Knowledge:** A Bachelor's Degree from an accredited college or university with an appropriate, current valid teaching certification as specified by the North Carolina Department of Public Instruction.

**Experience:** A minimum of two years teaching experience or direct residential experience with the target population is preferred.

**Skills/Working Conditions:** A valid North Carolina Driver's License and insurability by EHI's insurers is required. Work hours may include after hours, or weekend availability for trainings, all staff meetings. Must successfully complete pre-service workshop, including physical restraint training. Ability to easily and expeditiously climb and descend several flights of stairs, respond to a code, or call for staff assistance in the building or on campus. Position may experience verbal and/or physical aggression from the student population. Must provide a copy of current, valid teaching certificate at time of employment. Must maintain teaching certification by the North Carolina Department of Public Instruction and provide a copy of renewed teaching certificate to the principal upon completion of recertification requirements.

### Disclaimer Clause

Job descriptions are not intended, and should not be construed to be exhaustive lists of all responsibilities, skills, efforts or working conditions associated with this job. They are meant to be accurate reflections of the principle job elements essential for making fair pay decisions. This position description is not intended as a contract. A letter of employment confirms employment. North Carolina is an at-will employment state and Eliada is an at-will employer.

4/2012

## Position Description

**Job Title:** Administrative Assistant  
**Department:** Eliada Academy  
**Status:** Non-Exempt

**Salary Grade:**

### Position Summary:

The Administrative Assistant works under the supervision of the Eliada Academy Director and provides administrative support to the Eliada Academy program and staff.

### Major Responsibilities:

1. Provide accurate and thorough administrative and clerical support for the Eliada Academy Director and staff. Includes timely correspondence, organized filing systems, scheduling, financial record keeping, uniform distribution and inventory maintenance, routine transportation problem-solving, ordering, inventories, daily/weekly/monthly and annual agency reports, audit preparations and other duties as requested. Maintains confidentiality of student, staff and program records and information.
2. Facilitate and maintain accurate and organized current and archived school records including those pertaining to but not limited to: attendance and academic progress; official transcripts (including documentation of admission and withdrawals); Special education records; Title I Grant Records; and maintaining all incident report documentation.
3. Deliver/administer medications for students as required by licensure. Maintain accurate medication records. Schedule medication evaluation appointments with the Medical Director and transcribe all medication evaluation notes.
4. Manage administrative office for Eliada Academy in a friendly, professional and organized manner. Includes telephone contacts, visitors, client appointments, and physical appearance of office space, staff requests and other inquiries.
5. Approval of service notes for billing, filing service notes, assisting in maintenance of all records for all audits, including but not limited to: Clinical and Team Minutes, MDT minutes, Incident Documentation, Enrollment Log, Travel Packs and other records as needed or required.

### Other Responsibilities:

1. Display competence and responsiveness to cultural differences present in both student and staff population
2. Ensure the provision of quality services to students through participation in the agency's CQI process
3. Perform other related administrative and programmatic tasks as assigned by the Eliada Academy Director.

### Reporting Relationship:

Position reports to: Eliada Academy Director

### Qualifications:

**Knowledge/Experience:** Must possess a High School Diploma or GED. Must have a working knowledge of word-processing, spreadsheet, and database software and be able to operate basic office equipment. Prefer at least one year experience in clerical service.

**Skills/Physical/Working Conditions:** Position requires professional communication skills, excellent organizational skills and the ability to multitask. Ability to easily and expeditiously climb and descend several flights of stairs, or call for staff assistance in the building or on campus. Must be able to work in a high pressure, high stress environment. Position may experience verbal and/or physical aggression from the student population.

### Disclaimer Clause:

Job descriptions are not intended, and should not be construed to be exhaustive lists of all responsibilities, skills, efforts, or working conditions associated with this job. They are meant to be accurate reflections of the principal job elements essential for making fair pay decisions. This position description is not intended as a contract. A letter of Employment confirms employment. North Carolina is an at-will employment and Eliada is an at-will employer.

4/2012

Eliada Academy  
Employee Orientation Checklist

Employee Name:  
Date Employed:

Position:  
Preservice Dates:

Initial      Date

**Service Definition**

**Roles of Staff**

Day Treatment Program Director, Day Treatment  
Case Managers, Teachers, Treatment  
Associates, Clinicians, QP's, Adm. Asst.

**Staff Ratios**

1:4 In Classroom  
1:6 QPs in program

**Core Values and Person Centered Thinking**

Faith, Hope, Love, Teamwork, Excellence, and Integrity  
Respect, Compassion, Empathy, Confidentiality,  
Being Non-Judgmental and non-reactive  
Primary Focus is on Treatment  
Individual Student Focus

**Clinical Supervision**

Student Diagnoses and Treatment Plans  
Targets  
Symptoms  
Progress  
Strategies  
Restrictive Interventions  
Transitions  
Integrated Summaries

**Treatment Model**

Motivation System  
Balance Sheet  
Disciplinary Referral  
Teaching to Behaviors  
Skills Curriculum  
Crisis Management  
Safety of Students/Clients/Staff

**Emergency/Safety**

Radio Codes/Etiquette  
Fire Drills/Weather Drills  
Search & Seizure  
Restrictive Interventions  
Classroom organization and security



Building Security		
Keys		
<b>Student Expectations</b>	_____	_____
Classroom Rules		
Dress Code/Uniforms		
Handbook		
Transitions within the school day		
Lunchroom duties and procedures		
Boundaries		
<b>Documentation/Communication</b>	_____	_____
Block Updates		
Service Notes		
Incident Reports		
Requests to see Day Treatment Program Director or Day Treatment		
Role of Case Managers		
<b>Technology</b>	_____	_____
Personal Cell Phones		
Email		
School Use		
Personal Use		
Intranet/Eliada Net		
S Drive		
Eliada Folder		
Personal Folder		
Work Orders		
Use of Computer Lab/MAC equipment		
<b>Staff Expectations and Procedures</b>	_____	_____
Professionalism		
Dress Code		
Communication		
Meetings		
Student Monitoring and Supervision		
Supervision Plan/Goals		
Radios/Codes		
Radios on at all times		
TimeStar/Attendance		
Calling in		
Requesting PTO		
Meal Plan		
Building cleanliness and maintenance		
Copier/Supplies/Purchase Orders		
Medication		
<b>Curriculum and Instruction</b>	_____	_____
Grading Program/Progress Reports/Report Cards		

- Grading Scale
- Lesson Plans/Emergency Lesson Plans
- Standard Course of Study
- Classroom organization
- Classroom Management

Program Director \_\_\_\_\_ Date Completed \_\_\_\_\_

**Eliada Homes, Inc**  
**PRE-SERVICE PERSONNEL DOCUMENTATION CHECKLIST**  
*Eliada Academy Day Treatment*

Employee: \_\_\_\_\_ Date of Employment: \_\_\_\_\_

Date Complete Pre-Service Training: \_\_\_\_\_

The following items must be completed and signed by the last day of your Pre-Service Training. Give all items to the Program Compliance Officer.

\_\_\_\_\_ Job Description Read and sign in the upper right-hand corner of page 1. Get \_\_\_\_\_ your supervisor to sign as well.

\_\_\_\_\_ Code of Ethics Read and sign acknowledgement form.

\_\_\_\_\_ Agency Orientation Checklist Record date for the final day of Pre-Service. Sign and have your supervisor sign.

\_\_\_\_\_ Results of TB test, current within one year.

\_\_\_\_\_ Copy of valid NC Driver's License

\_\_\_\_\_ Pre-Service Training Agenda for Teachers. Sign and get your supervisor's \_\_\_\_\_ signature. Following are the required training sessions:

- Prevention of Child Abuse/Supervision & Monitoring
- Learning Theory/Teaching Approach
- Student Population
- Skills Curriculum
- Tolerances, Observing & Describing, Relationship Building, Preventive, Positive, Corrective, and Intensive Teachings
- Client Rights
- DBT Skills
- TCI
- Blood Borne Pathogens
- CPR
- First Aid

\_\_\_\_\_ Copy of college transcripts mailed to Eliada's Human Resource (HR) office.

\_\_\_\_\_ Privileging Form. Get Program Compliance Officer to complete privileges and sign.

\_\_\_\_\_ Teachers – copy of current teaching certificate. NC certification or application for certification is preferred.

## **Eliada Homes, Inc. Day Treatment Service Definition Training Four Hour Curriculum Elements of Service**

- **Structured Treatment**
  - Licensed, Endorsed and Accredited
  - Strength-based
  - Addresses targeted needs
  - Case Management Services
- **Medically Necessary**
  - Diagnosed mental, behavioral and/or emotional disturbances
  - Comprehensive Clinical Assessment (CCA)
  - Person Centered Plan (PCP)
- **Therapeutic Interventions**
  - Clinically designed to reduce symptoms, improve behaviors, and improve relationships with peers and families
  - Goal oriented
  - Coordinated with Academic and Vocational Services
  - Developmentally appropriate for children ages 8-17
  - Culturally sensitive
  - Child and Family Centered
  - Safe, healthy and appropriate
  - Evidenced-Based and consistent with Best Practice
- **Collaboration with Local Education Agencies**
  - Memorandum of Agreement
  - Transition Planning
- **Staff Training**
  - Qualified Mental Health Professionals(QP)
  - Training:
    - System of Care (ongoing)
    - Person Centered( 8 hours)
    - Service Definition (4 hours)
    - Treatment Interventions (1 hour/month minimum; weekly clinical meetings)
    - Preservice Training (10 days)

## Roles/Responsibilities

### Job Titles:

- Day Treatment Program Director (also a QP)
- Licensed Clinical Supervisor
- Lead QP Treatment Specialist
- QP Treatment Specialist (QPTS)
- Treatment Associate (TA)
- Case Manager (CM)
- Teacher

### Roles and Responsibilities

#### Qualified Mental Health Professionals (QP)

- **Director**
  - Qualified Mental Health Professional with a Master's Degree and two years experience with target population
  - Knowledge and skills to work with targeted population
  - Actively develops, manages, and implements programming and service delivery
  - Monitors and evaluates delivery of treatment activities
  - On-Call Responsibilities
  - Provides QP supervision during times of crisis
- **Clinical Supervisor**
  - Approves and oversees all treatment activities planned by LQPTS and QPTSs
    - Developmentally Appropriate
    - Culturally Relevant and Sensitive
    - Direct Preventive and Therapeutic Interventions
  - Leads and plans treatment interventions
  - Assures QP Ratios (1:6) and staff ratios (1:4) in the program
  - On-Call Responsibilities (Agency)
- Provides QP supervision during times of crisis
- **One Full-time Clinician**
  - Completes CCAs
  - Provides Clinical Supervision to Treatment Staff
  - Actively involved in delivery of services to clients
    - Individual, Family and Group Therapy
    - Crisis intervention as needed
- **Case Managers (2.5)**
  - Person-Centered Planning Process
    - Person Centered Plans (PCP)
      - Treatment
      - Crisis Plans
      - Transition Plan
    - Child and Family Team (CFT)
      - Convene
      - Coordinate the provision of multiple services

- Development and revision to the PCP
- Primary point of contact for family and team members
- Transition Planning
- Collaboration with local education and service agencies
- Assessment and Monitoring
  - Assess the child's need for comprehensive services
  - Monitor the provision of services and supports
  - Assess the outcomes of services and supports
  - Provides guidance to treatment team regarding interventions and strategies as related to treatment goals and targets
- Documentation
  - Audit-proof Records
  - CCA (Comprehensive Clinical Assessments)
  - PCPs
  - Requests for additional evaluations
  - Service Note:
    - Training
    - Approval

#### **Lead QP Treatment Specialist (1)**

- Plans, leads and implements treatment interventions
- Part of 1:6 student ratio
- Monitors 1:4 staff to student ratio (adjusts schedule)
- Service Notes-Writing and approving
- Partners with all staff providing treatment and support to the child
- Supervision/modeling/feedback in classroom with QPTS and Treatment Associates
- Crisis management and interventions
- Approves incident reports
- Plans and participates in Student Motivators and field trips
- Safety Council and monitor of building safety
- Training of new staff
- Behavior Model implementation/evaluation/revision and planning

#### **QP Treatment Specialist (3.5)**

- Plans, leads and implements treatment interventions
- 1:6 student ratio
- Service Notes-Writing and approving
- Partner with all staff providing treatment and support to the child
- Supervision/feedback in classroom with QPTS and Treatment Associates
- Crisis management and interventions

#### **Treatment Associate (3)**

- Direct supervision of students
- Implementation of Treatment interventions and strategies
- Write service notes and Incident Reports
- Write block updates
- Provide support to staff and teachers leading activities

## Teacher (4)

- Separate cost center/underwritten by Eliada's Foundation and Sisters of Mercy Grant
- Curriculum, Instruction, and Assessment
- Student supervision/classroom management
- Assist with behavioral and treatment interventions
- Write updates and Incident Reports as needed

## Person Centered Thinking

Orientation and training of staff in the Day Treatment program at Eliada Homes, Inc. is an integrated and holistic approach to focusing on each child as an individual with unique needs, talents, skills, abilities and potential. While this list is not exclusive and there are other words to describe what we do and talk about, this is an outline of what we believe and practice in our treatment program for children in Day Treatment. We are always focused on the student and Person Centered Thinking/Planning/Treatment.

### Pre-service

See the highlighted items on the agenda and addendum for Pre-Service Training for all staff

### Orientation Checklist

See pp. 1-3

### Core Values and Person Centered Thinking

Eliada Homes, Inc. as an agency developed the Core Values of Faith, Hope, Love, Teamwork, Excellence, and Integrity to guide the work that we do with each child and family admitted to our program(s). Training in these core values begins in pre-service (and even before in the interview process) and becomes part of the common metric, the common vocabulary, the common denominator for all interactions with a client and their families or caregivers. We teach that respect, compassion, empathy, confidentiality and maintaining the dignity of each member of this team are critical factors in our success and the successful completion of a child's treatment. Staff members are trained to put their primary focus on treatment, being non-judgmental and non-reactive to details of a client's history or disclosures they may make during treatment. Each child is treated as an individual at all times.

### Clinical Supervision

Formal Clinical Supervision meetings are held nearly every week and attended by all staff (except on-call PRN staff that may not be scheduled that day) to staff and discuss the details of three to four individual students' treatment. The clinician assigned to the Day Treatment program facilitates the meeting, beginning with a discussion of the student's diagnoses. Prior to the meeting, the child's advocate has prepared a document with the initial lists of progress and symptoms of the student. The staff discusses and edits these lists, leading to the development of strategies and revised goals or targets for the student. These meetings provide ongoing training and insight in to different diagnoses and how these diagnoses impact individual student behaviors and treatment strategies. Transition plans are discussed and if discharge is imminent, a triggers and strategies document is created and then shared with the school the child will be attending.

### Informal Training

Informal training begins after orientation and when staff members are delivering direct care and treatment to children. Throughout each day, great consideration is given to each individual child's diagnoses, treatment plan, personality, state-of-mind, feelings, life circumstances (what has been happening in their life outside of the Day Treatment program), interactions with peers and adults and any other extenuating circumstances (are they feeling well, court date looming, injuries, previous problems-including restrictive interventions, etc.) Clients begin each day with a 30 minute check-in with their advocate and after each transition, client updates are shared with all Eliada Academy staff. In these updates behaviors both positive and corrective are noted and additional notes regarding how the client handled the time and treatment teachings are documented. While the Eliada Treatment Model is structured and has a similar foundation for every student, individual students are approached with the model in a manner that is unique to their needs.

Throughout treatment clients benefit from working with the treatment staff who teaches them how to make good decisions, practice life skills, to become self-reliant, self-directed and able to transition to either a public school or workforce setting.

Staff members are also trained in using Dialectical Behavior Therapy (DBT) strategies, de-escalation techniques, and event processing before, during and after incidents involving and off-task child, through debriefing, clinical meetings, and role-modeling from more experienced staff.

Each year, Eliada Homes, Inc. develops goals or initiatives to improve the delivery of services to clients and families admitted into an Eliada program. This year the initiatives that have been introduced are improving our cultural competency across campus and increasing the integration and expectations of family involvement in the treatment of their child and family unit.

## Clinical Supervision

Clinical meeting expectations:

- ☀ Meeting starts promptly at 3:00pm; everyone is expected to attend except PRNs (who are on a different schedule); note will be made of those arriving late or not at all
- ☀ Meeting ends no later than 4:00pm
- ☀ Case manager(s) for students being presented that day are expected to attend
- ☀ ICMPs are to have been reviewed and updated by advocates prior to clinical
- ☀ Advocate will present his/her student, with case manager(s) providing relevant updates from CFT meetings, contacts with family, etc.
- ☀ Incoming students will be presented by Clinical Supervisor or Program Director

### Eliada Academy Day Treatment INDIVIDUAL CLINICAL TREATMENT PLAN (ICTP)

To be completed by first clinical staffing of student. Case Manager, QP, and Advocate responsibility

Student Name: \_\_\_\_\_ DOA: \_\_\_\_\_  
Student Advocate: \_\_\_\_\_ Clinician: \_\_\_\_\_

<b>Complete for Clinical Staffing only</b>		
<b>Date:</b>	<b>Clinician Signature:</b>	
<b>Facilitator:</b>	<b>QMHP Signature:</b>	
<b>Time Started:</b>	<b>Time Ended:</b>	
<b>Staff Present:</b>		
<b>Staff Absent &amp; Reason for absence:</b>		
<b>Notes from Case Manager:</b>		
<b>What is the clinical Best Practice for each diagnosis?</b>		
<b>Diagnosis</b>	<b>Specific Behaviors/Symptoms</b>	<b>Strategies</b>

<b>Long Term Plan and Family Goals: (from PCP)</b>	
<b><u>PROGRESS</u></b>	<b><u>SYMPTOMS</u></b>
<b><u>Current Targets</u></b>	<b><u>New Targets</u></b>



**Cultural and Developmental Considerations:**

What activities is your family involved with?  
What are your customs for celebration of holidays?  
What holidays do you celebrate?  
If you go to church, which one do you prefer?  
What are some of your favorite foods?  
What is your family heritage?

**Short and Long Term Motivators:**

**Current Treatment Theme:**

**Program Specific Treatment Interventions:**

Date Updated (as needed):

Advocate Name:

**INDIVIDUAL CRISIS MANAGEMENT PLAN (ICMP)**

Student Name: \_\_\_\_\_

DOA: \_\_\_\_\_

**Safety Concerns – Warnings** – (medical & physical concerns, medication, abuse history, specific plans):

Specific De-escalation Strategies:

Preferred restraint positions:

**Current Issues – Potential Triggers** (personal / family / social, etc.):

---

---

**High-Risk Behaviors:**

---

---

---

**Intervention Strategies:**

**Pre-Crisis**

*Behavior:*

*Strategies:*

**Triggering**

*Behavior:*

*Strategies:*

**Escalation**

*Behavior:*

*Strategies:*

**Outburst**

*Behavior:*

*Strategies:*

**Recovery**

*Behavior:*

*Strategies:*

<b>Date Updated:</b>	<b>Advocate Name:</b>
<b>Contacts: Insert from PCP/SEDCARE</b>	
<b>Copy of Crisis Plan from PCP:</b>	

**Eliada Day Treatment Behavior Model  
June 2011**

**SUCCESSFUL COMPLETION OF TREATMENT**

Violet Citizenship



**Indigo: Caring for Self and Others**



**Level Three**



**Blue: Integrity**



**Green: Trustworthiness**



**Level Two**



**Yellow: Honesty and Fairness**



**Orange: Respect and Responsibility**



**Red: Basic Skills and Emotion Awareness**



**Level One**

**Miscellaneous Notes and Suggestions:**

- 30 minute homeroom at beginning of the day to work on Level assignments
- Elementary class to flex their time and integrate skills and activities into the daily curriculum
- Use pre-written packets, revise and modify and label “Eliada Academy Behavior Modules”
- Evidence-Based Practices:
  - Teaching Families-Emerging
  - PBIS-Emerging
  - DBT
  - Aggression Replacement Training
  - Cognitive Behavior Therapy
  - Character Counts-Emerging/evidence-based
- Usual rules of behavior applies
- Put “go to” box of cards in Focus Area to help with ideas for self-soothing
- Reflection form to be reviewed/processed with CM, Clinician as a follow-up (similar to LSI)
- Need to figure out the evaluation piece
- What are the expectations for mastery
- Review for Bronze to Silver to Gold levels made at a Team level
- Color levels reviewed by HR team/staff
- Gold application and self assessment
- What do we need to do for kids who get stuck on a level?

**General Guidelines**

- Always treat students with respect and empathy (every one of them has worth and value and are here to be helped in learning how to navigate the world successfully as they learn and practice new skills...there are no “bad” kids. There may be kids who need a different or higher level of care than we can provide in Day Treatment)
- Ask more questions
  - Responsible Thinking questions are good for most situations:
    1. What are you doing? Or What did I see you doing?
    2. What are the rules? Or Is that okay?
    3. What happens when you break the rules?
    4. Is that what you want to have happen?
    5. What do you need to do to fix this? (Jan’s addition)
    6. What happens if you do it again?
- Always treat colleagues with respect
- Hold each other accountable by giving gentle reminders and constructive feedback as well as praise and compliments.
- If you don’t know, ask questions
- Use the model as intended and your own personal style in how you deliver treatment
- Use natural and logical consequences whenever possible to individualize treatment
- Be the “rope” and avoid power struggles at all costs! (you can’t push a rope, but if you get all rigid, the power seeking student will have something/someone to push against)
- Remember to find humor in everyday activities

- If you feel yourself being triggered by a student, swap out with another staff person
  - If a colleague offers to switch out with you, there is probably a reason. Switch out and ask questions later.
  - Don't make assumptions\*
  - Don't take anything personally\*
  - Be impeccable with your word\*
  - Always do your best\*
- \*From The Four Agreements

## At the beginning of the day:

We control (sort of ☺) about 6.5 hours of our students' lives. The other hours they are in environments dealing with people and situations that most of us can barely imagine. When they come to school we need to find out what we can, so we can offer them appropriate treatment interventions and a little Faith, Hope and Love where we can.

Be proactive and do preventive activities to help students get started in a positive way at the beginning of the day. Remember, your kind word could be the first one they have heard since they left here the day before.

Offer the opportunity for students to drain off some emotion from the night before or the morning of school.

- Ask them to write down anything that is bothering them or taking up space in their heads and then either put it in an envelope or a box or something and tell them they have put these thoughts and issues aside and are now free to work on their academics and their treatment for the rest of the day
- Do a timed check in where any student who wants to share has a pre-determined amount of time to share their questions, comments and concerns about their own issues
- Ask the students to rank (numerically) how they are feeling emotionally or physically at the beginning of class, then again at the end or later in the day when they return to you. This could be an opportunity to discuss what they did that made things better or worse since the morning.

## Misc.

- In a folder in each classroom will be a few laminated worksheets that the students can use to reflect on their behavior. They will then write their responses in their journal or on a piece of paper to put in their portfolios which will then be shared at monthly CFT meetings.
- Mix up activities so that the students are not always completing worksheets. When giving choice activities, do not always offer a word search...mix it up with activities and work that makes the students think and reflect. Higher Level Thinking and problem-solving is practice our students need on a regular basis.
- All "paper products" from activities must be completed on 8.5" x 11" paper so that it will fit in their portfolio. Pictures of 3D objects can be mounted on paper/cardstock and put in the portfolio too.
- All "Level" work will be stored in a folder in the student's homeroom.
- High standards for all work

- Neat/clean/legible
- Correctly spelled
- Correct grammar
- Correct punctuation
- Not crumpled up (re-do!)
- Progress on levels to be discussed at CFT meetings each month. Student needs to present their work to their team.

**Friday Note: To Jan**

**Date:**

Please fill out this form on Fridays, or more often if you have feedback or ideas for me. You can type on the document and leave it under my door if you want anonymity. Or, fill it out and email it. I promise that there will be no backlash if you choose to identify yourself and if you do identify yourself, I can make sure I understand you if there are questions about something you wrote. (you can type on this document and make it as long or short as you like)

- **What went well this week?**
- **What would you change if you could change the past week's lessons or activities?**
- **What was your biggest struggle or frustration this week?**
- **What did others do that you would like to acknowledge and praise?**
- **What constructive feedback did you share?**
- **What can I (or anyone else for that matter) do to support you?**
- **Are there any repairs (technology or maintenance) that need to be made to your area or other part of the building that you noticed?**
- **Program ideas you want to share before you forget ☺?**

**Submitted by:**  
**(Optional, but encouraged ☺)**

#### **BASIC SKILLS**

1. Following Instructions
2. Accepting Consequences
3. Accepting No
4. Accepting Criticism
5. Asking Permission

6. Disagreeing Appropriately
7. Greeting Skills
8. Departure Skills
9. Volunteer for a Task
10. Offer to Help

## DAILY SKILLS

1. Accepting Apologies
2. Accepting Compliments
3. Accepting Decisions of Authority
4. Anger Control Strategies
5. Appropriate Appearance
6. Appropriate Voice Tone
7. Appropriate Word Choice
8. Asking For Help
9. Asking Questions
10. Asking for Clarification
11. Attends School
12. Being on Time
13. Checking In
14. Completing Homework
15. Completing Tasks
16. Complying with Reasonable Requests
17. Contributing to Discussions
18. Conversation Skills- Initiating,
19. Conversation Skills- Maintaining
20. Conversation Skills- Closing
21. Correcting Others/Giving Criticism
22. Following Rules
23. Following Written Instructions
24. Getting Another Person's Attention
25. Getting the Teacher's Attention
26. Giving Compliments
27. Good Quality of Work
28. Ignoring Distractions by Others
29. Interrupting Appropriately
30. Introducing Others
31. Listening to Others
32. Making an Apology
33. Making a Request
34. Participating in Activities
35. Personal Hygiene
36. Positive Self Statements
37. Positive Statements about Others
38. Ref. from Poss. Drugs/ Contraband
39. Reporting Emergencies
40. Reporting Other Youths' Behaviors (Peer Reporting)
41. Resisting Peer Pressure
42. Say "No" Assertively

43. Seeking Positive Attention
44. Showing Appreciation
45. Showing Interest
46. Staying On Task
47. Structured Prob. Solving (SODAS)
48. Table Etiquette
49. Waiting Your Turn
50. Willingness to Try New Tasks

## WEEKLY SKILLS

1. Accepting Help/ Assistance
2. Accepting Defeat/ Loss
3. Accepting Winning Appropriately
4. Accepting Responsibility
5. Age Appropriate Activities
6. Analyzing Social Situations
7. Analyzing Skills Needed for Different Situations
8. Analyzing Tasks to be Completed
9. Apologizes/ Expresses Regret
10. Appropriate Clothing Choice
11. Being Prepared for Class
12. Care of Own Belongings
13. Choosing Appropriate Friends
14. Complying with Campus Dress Code
15. Compromising with Others
16. Communicating Honestly
17. Concentrating on Task
18. Controlling Emotions
19. Controlling Eating Habits
20. Con. Sexually Abusive Impulses
21. Controlling Impulse to Lie
22. Controlling Impulse to Steal
23. Cooperating w/Others
24. Coping w/ Anger and Aggression from Others
25. Coping with Change
26. Coping with Conflict
27. Coping with Sad Feelings
28. Dealing with Accusation
29. Dealing w/ Being Left Out
30. Dealing with Boredom
31. Dealing w/Contradictory Messages
32. Dealing w/ Embarrassment
33. Dealing with Fear
34. Dealing with Frustration
35. Dealing with Group Pressure
36. Dealing with Rejection
37. Decision- Making
38. Delaying Gratification
39. Displaying Effort
40. Emotional/ Impulse Control
41. Expressing Appropriate Affection
42. Expressing Feelings Appropriately
43. Expressing Optimism
44. Expressing Pride in Accomplishments
45. First- Aid/ Self Medication
46. Following Safety Rules
47. Following Through on Agreements and Contracts
48. Giving Instructions
49. Giving Rationales
50. Ignores Minor Inappropriate Behavior
51. Interacting Appropriately w/ Opposite Sex
52. Keeping Property in Its Place
53. Making New Friends
54. Making Restitution
55. Negotiating w/ Others
56. Meal Planning
57. Organizing Tasks and Activities
58. Persevering on Tasks
59. Preparing for Stressful Conversation
60. Preventing Trouble w/Others
61. Problem Solving a Disagreement
62. Relaxation Strategies
63. Reports Whereabouts
64. Respond to Complaints
65. Respond to Others' Feelings

17. Gathering Information
18. Goal-Setting
19. Identifying Own Feelings
20. Interviewing for a Job
21. Job Finding Strategies
22. Laughing at Oneself
23. Leadership Skills
24. Maintaining Relationships
25. Making an Appropriate Complaint
26. Patience
27. Planning Ahead
28. Recognizing the Moods of Others
29. Resigning from a Job/ Project
30. Rewarding Yourself
31. Seeking Professional Assistance
32. Self-Monitoring/ Reflection
33. Shows Respect for Others
34. Stress Management
35. Thought Stopping
36. Tolerating Differences
37. Use of Leisure Time
38. Utilizing Community Resources

## ADVANCED WEEKLY SKILLS

1. Accepting Self
2. Altering One's Environment
3. Appropriate Risk Taking
4. Asking For Advice
5. Assertiveness
6. Assessing Own Abilities
7. Being an Appropriate Role Model
8. Budgeting and Money Management
9. Clarifying Values and Beliefs
10. Conflict Resolution
11. Consumerism
12. Differentiating Friends from Acquaintances
13. Displaying Appropriate Control
14. Expressing Empathy/ Understanding for Others
15. Expressing Grief
16. Formulating Strategies
17. Gathering Information
18. Goal-Setting
19. Identifying Own Feelings
20. Interviewing for a Job
21. Job Finding Strategies
22. Laughing at Oneself
23. Leadership Skills
24. Maintaining Relationships
25. Making an Appropriate Complaint
26. Patience
27. Planning Ahead
28. Recognizing the Moods of Others
29. Resigning from a Job/ Project



**Balance Sheet Procedures**

The **Purpose** of the Balance Sheet is to provide the students with an opportunity to track their behaviors, abilities to change those behaviors and to see a chain of cause and effect of those behaviors and choices. Additionally, the document provides daily feedback to students and information to parents and guardians and can be reviewed by the CFT for progress and continuing symptoms for students. Day Treatment also used the data to inform treatment and devise strategies to further assist students in their quest for success.

Students on levels One and Two receive a balance sheet at the beginning of each day when they return their signed balance sheet from the previous day.

Students record positives and consequences on the balance sheet and keep a running total of the dollar value each day for each block of class

Staff teach to behaviors small and large (positively and with consequence)

Target behaviors earn \$1.00

Non-Target behaviors earn \$.50

No Balance sheet = \$10 fine

Balance sheet returned but not signed = \$5 fine

No binder/folder = \$1.50 (responsibility fine)

No uniform = \$5 fine first time, \$10 fine thereafter

Sagging = \$5 fine first time, \$10 fine thereafter

Secretive behavior = \$5

Pen charge = \$10 to rent a pen (you get \$6 back if you return the pen the same day you borrowed it)

No H/W = \$1.50 fine first day, increasing by .50 every day up to \$5 (per event)

Weekly attendance = \$1.50 award; daily attendance = .50 award

Lunchtime Etiquette = \$1.00/day (DINING DOLLARS)

Practices, if successfully completed on the same day, earn back ½ value. If completed the next school day, earn only .25

See Ongoing procedures for consequence structure

**Students must:**

- Write legibly
- Complete the entire balance sheet front and back
- List behaviors for each positive or consequence
- Compute their balances correctly (staff will check math computations each block and at the beginning and end of each day)
- Record the number of Positives and Consequences each day

**Balance sheet procedures**

- Staff will review balance sheets to make sure that the top and back are filled out completely
- Staff will sign each behavior, practice and ongoing during each block
- Balances carry over daily for one week
- At the beginning of each week, balances all reset to ("0") zero.
- On Monday mornings, staff will convert the whole dollar value of the balance sheet to points and record it (ex. Balance of \$7 becomes 7 points; negative balances = 0 points) Form will be kept in crate with balance sheets
- Ongoing will be recorded on a form
- Balance sheets will be collected and filed by student and stored in a file cabinet drawer
- Each staff needs to sign the positives/consequences/ongoings/practices that they assigned to students

**Points**

Points will be used to award motivators. The values will be determined later based on the Day Treatment Economy and the motivator activities themselves.

During the week, students may purchase school store items with the dollars they have earned. These dollars will then be ineligible for point conversion at the end of the week.

**Rationales**

Rationales/reasons for the positive or the consequence are to accompany every teaching, be it positive or corrective. Do not "over-talk" rationales and ask the students to provide their ideas on what the rationale might be.

Before sharing any rationales, ask the student if they are ready to process the behavior:

- If they say no, then give them more time and space and/or offer Focus Time
- If they say yes with an attitude, say "I am not hearing that you are ready. We will wait a little bit and I'll check in with you later."
- If they say yes, praise them and then ask them why it is important to demonstrate the appropriate behavior, after they answer, begin a dialog that relies heavily on you asking questions and them providing the answer

LEVEL ONE BALANCE SHEET/Step Color RED, ORANGE, YELLOW (circle)

Name: \_\_\_\_\_ Date: \_\_\_\_\_ Day: \_\_\_\_\_

Target#1: \_\_\_\_\_ Target#2: \_\_\_\_\_ Balance: \_\_\_\_\_

Consequence (after 1<sup>st</sup>, becomes an Ongoing) Values: 1st: Earn -\$0.50\* 2nd: Earn -\$1\* 3rd: Earn -\$2\* 4th: Earn -\$3 5th: Earn -\$5

"O" indicates an Ongoing Process; "P" indicates a Practice/earn back 1/2 value of Consequence with a Practice

<i>Class Name</i>	<i>Behavior</i>	<i>+Positives (add)</i>	<i>-Consequences (subtract)</i>	<i>Balance</i>	<i>Staff Initials/ O or P</i>
EX. Math	Accepting Decisions of Authority	1.00			JT
Math	Not Accepting Consequences		.50	.50	JT
	Not Accepting Consequences		1.00	-.50	JT/O
	Deduct School Store Purchases				
+s	<b>TOTAL DOLLARS</b>				
-s	<b>TOTAL POINTS (WEEKLY)</b>				

Academy Target:

- \_\_\_\_\_
- 1. \_\_\_\_\_
- 2. \_\_\_\_\_
- 3. \_\_\_\_\_
- 4. \_\_\_\_\_
- 5. \_\_\_\_\_

- 3. \_\_\_\_\_
- 4. \_\_\_\_\_
- 5. \_\_\_\_\_

Personal Target #1 :

- \_\_\_\_\_
- 1. \_\_\_\_\_
- 2. \_\_\_\_\_
- 3. \_\_\_\_\_
- 4. \_\_\_\_\_
- 5. \_\_\_\_\_

Personal Target: #2

- \_\_\_\_\_
- 1. \_\_\_\_\_
- 2. \_\_\_\_\_

**Safety Violations:**

- Aggression toward Persons or Animals
- Destruction of Property
- Forging, Stealing or Cheating
- Aggressively Moving Furniture
- Leaving the group or building without permission
- Fighting/Bullying
- Boundary Violations
- Excessive Truancy
- Illegal activities of any kind
  - Bring contraband or drugs to school
  - Bringing a weapon to school

May result in student appearing before Safety Council

Guardian Signature: \_\_\_\_\_ Date: \_\_\_\_\_

Personal Goal for the Week:

\_\_\_\_\_

**LEVEL ONE BALANCE SHEET/Color RED, ORANGE, YELLOW (circle)**

Name: \_\_\_\_\_ Balance: \_\_\_\_\_

Date: \_\_\_\_\_ Day: \_\_\_\_\_

Focus Behavior:

\_\_\_\_\_

Solution 1:

\_\_\_\_\_

Solution 2:

\_\_\_\_\_

Skill: Introducing yourself

\_\_\_\_\_  
\_\_\_\_\_

Skill: Apologizing

\_\_\_\_\_  
\_\_\_\_\_

Skill: Saying thank you

\_\_\_\_\_  
\_\_\_\_\_

Skill: Offering help to an adult

\_\_\_\_\_  
\_\_\_\_\_

Skill: Staying out of fights

Skill: Making a complaint

Skill: Recognizing another's feelings

Skill: Avoid trouble

Skill: Responding to teasing

Skill: Answering a complaint

Skill: Giving a compliment

Skill: Completing an assignment

<b>Other Skills:</b>
<b>PCP Target and Skill:</b>
Guardian Signature: _____ Date: _____
Comments: ****One sticker is worth \$0.25 in the school store****

DOTS (Directly Observable Treatment System) DOTS are just exactly what they sound like. Looks much like a “splat” on the balance sheet.

If a student earns a DOT (consequence) for NOT following basic Academy expectations, they have a DOT recorded (by staff) on the balance sheet.

Each dot is worth .25 cents to be subtracted from their daily balance. If a students receives 12 dots during one Academy Day...we subtract \$3.00 from the daily earned balance.

Example:

DD earns 15 stickers for following a variety of Academy Expectations. HOWEVER, he leaves his desk without permission from staff. Staff takes their DOT MAKER and makes a DOT on DD’s balance sheet next to the skill “Asking Permission”. If he continues breaking that expectation during the day, he continues getting DOTS next to that skill. DD et al. will be able to track his specific BEHAVIORS and know more about what he specifically needs to work on.

It was suggested by the Elementary students that we design a chart for the classroom to keep track of days that each student reach a particular pre-determined dollar amount for the day...”Dollar Days”

Students will earn a “special mark” on the chart each day they earn, say, \$20.00 on their balance sheet...this will give students some short and long term goals with their balance sheets.

The student with the most “special marks” on the Dollar Days chart will earn a special motivator.

Each time a student reaches a goal (Five \$20.00 Dollar Days in a row; 10, 20, etc.) they can earn monies in their “bank account” for purchases at the school store. This dollar amount is in addition to the dollars they earn on a weekly basis in class. If the ENTIRE CLASS has a pre-determined number of Dollar Days in a row....then there would be a special event for entire class (pre-established).



**AND THINK ABOUT IT.**

**THESE BEHAVIORS HAVE CONSEQUENCES** □

No Balance sheet = \$10 fine

Balance sheet returned but not signed = \$5 fine

No binder/folder = \$1.50 (responsibility fine)

No uniform= \$5 fine first time, \$10 fine thereafter

Sagging= \$5 fine first time, \$10 fine thereafter

Secretive behavior= \$5

Pen charge= \$10 to rent a pen (you get \$6 back if you return the pen the same day you borrowed it)

No H/W = \$1.50 fine first day, increasing by .50 every day up to \$5 (per event)

Weekly attendance= \$1.50 award; daily attendance = .50 award

Lunchtime Etiquette= \$1.00/day (DINING DOLLARS)

**MAKE WISE CHOICES. WE KNOW YOU CAN!!!!!!**

**ONGOING CONSEQUENCES**

Whenever a student does not respond appropriately, the first time, a staff issues a consequence for negative or inappropriate behaviors, the student will receive up to five additional consequences whose negative dollar values are listed below:

Consequence	Fine (subtract)	Practice (add)
1 <sup>st</sup>	(-) .50	.25
2 <sup>nd</sup>	(-) 1.00	.50
3 <sup>rd</sup>	(-) 2.00	1.00
4 <sup>th</sup>	(-) 3.00	1.00
5 <sup>th</sup>	(-) 5.00	1.00

After five consequences, the process stops until the student is in a better place to cooperate and learn from the experience.

**Prior to taking a student into an ongoing, please consider the following:**

Have you?



- Used planned ignoring or wait time/time and space?
- Have you offered Hurdle Help?
- Have you offered praise (it often surprises them out of their inappropriate behavior)
- Have you asked them what they need right now?

**Check in with yourself:**

- What is your intent?
- What time of day is it? (1<sup>st</sup> or last thing in the day may not be effective)
- The individual student
- What is the mental/emotional state of the student right now?
- Could the student be hungry?
- Is this likely to develop into a power struggle? (remember, they always win if we engage in a power struggle with them)
- Are you “choosing” this “battle?”

**During and after an ongoing:**

- Keep a neutral voice tone, facial expression and other body language
- Avoid setting up an environment where the student feels humiliation
- Give them time and space to process the current consequence before moving to the next
- Afterwards, before going through any rationales, ask the student if they are ready to process
  - If they say no, then give them more time and space and/or offer Focus Time
  - If they say yes with an attitude, say “I am not hearing that you are ready. We will wait a little bit and I’ll check in with you later.”

If they say yes, praise them and then ask them why it is important to demonstrate the appropriate behavior, after they answer, begin a dialog that relies heavily on you asking questions and them providing the answer

**Ongoing Consequences Data Sheet (one per student)**

Name: \_\_\_\_\_

Week: \_\_\_\_\_ Previous Week’s Points \_\_\_\_\_

Balance Sheet	Level	Balance	Returned	Signed	Points
Monday					
Tuesday					

Wednesday					
Thursday					
Friday					
Week Total					

Week: \_\_\_\_\_ Previous Week's Points \_\_\_\_\_

Balance Sheet	Level	Balance	Returned	Signed	Points
Monday					
Tuesday					
Wednesday					
Thursday					
Friday					
Week Total					

Week: \_\_\_\_\_ Previous Week's Points \_\_\_\_\_

Balance Sheet	Level	Balance	Returned	Signed	Points
Monday					
Tuesday					
Wednesday					
Thursday					
Friday					
Week Total					

**Ongoing Consequences Data (Teacher Summary)**

Teacher/Staff: \_\_\_\_\_

Month/Year: \_\_\_\_\_

Student Name	M	T	W	TH	F	T O T	M	T	W	TH	F	T O T	M	T	W	TH	F	T O T

**Calling for Support in a Crisis**

- When calling for support, please speak as clearly as possible so there is no question about where help needs to run to J
- If you are responding, please state your name and then “responding” EXAMPLE: “Thomas responding”
- Then, everyone else stays where they are!
- If you are in route with students, please go to an alternate location (computer lab, porch, vacant classroom) until you can check to see that it is clear to return to that space.
- Whenever there is a designated Crisis On-Call person, that person needs to be the first responder.

**Suggested Structure for Home Room**

8.15-8.35: Students have breakfast, collect balance sheets, check-in with students

8.35-8.55: Time to Move! (Pedometers, etc.) On wet days we will need to have alternative activities ([www.powertyping.com](http://www.powertyping.com) for typing drills, [www.typingtest.com](http://www.typingtest.com) for improving typing speed; I believe we are getting some good board games, jigsaws, etc related to the “Round the World” theme; Brain Teasers and puzzles [http://www.puzzlechoice.com/pc/Kids\\_Choicex.html](http://www.puzzlechoice.com/pc/Kids_Choicex.html) Other ideas?

**1<sup>st</sup> Block begins at 9:00**

12.30 – 1.15

1. Begin with warm-up posted on the board. May give prompt as to number of sentences, time-limit for writing, etc.
2. Check-in again. (May do individually or as a larger group, depending on what is happening.)
3. Individual assignments for students to work on their folios. (Balance student activities so that some students may be working on a role-play, others may be completing a poster/worksheet, etc.)

FOLIOS WILL ALWAYS STAY IN HOME ROOM.

We want the finished article to be of a high quality and so attention should be paid to presentation and mechanics of spelling, etc.

### Transition Expectations for Students

- Line up at the door **appropriately** (this means **SILENTLY** and within an **arm's length** of each other)
- Only exit the room when instructed by an adult
- Go **UP** the **front staircase** and **DOWN** the **back**
- Walk **SLOWLY (NEVER RUN!)** Step on each stair and do not jump the steps or skip steps.
- Keep **good boundaries. Stay at least one arm's length from others at all times. NO touching!**
- Remain **SILENT** during transitions
- When walking **up OR down** the **stairs**, always **stop** on **EACH landing** and wait for your adult to join you. Do not turn the corner and begin the next set of stairs until the adult says, **"OK"**
- Always remember to **stop** at **EACH designated "stopping point"** and wait for the **"OK"** before continuing
- **NEVER jump** to try to reach **ANYTHING** above you
- When arriving at your destination, **line up** quietly **BEFORE ENTERING** the room. Stay within **arm's length** of each other and wait for the **"OK"** before entering the room

- **ANY transition violations will result in fines and/or other consequences**

### Cafeteria Expectations

- Students and staff will observe a moment of silence at the beginning of lunch
- Three students at a time may go to the serving line to get their lunch when told to do so by staff
- Students will use appropriate table manners and voice volume and tone while eating lunch
- Once seated for lunch, only one student at a time may get back up (with staff's permission) Students should not need to repeatedly go back and forth to get items
- After each lunch period, students will wipe/clean ALL tables (and chairs and floors if needed) before leaving the cafeteria
- The last five minutes of lunch will be silent to prepare for transition
- Show respect and consideration towards the staff who serve lunch and also to those who use the workspace around the lunchroom – say please and thank you, move chairs quietly, etc



### **Silent Lunch**

- These students will go to the serving line last
- Students may not read, write, draw, do other activities, or speak to others *unless* they have a specific question about lunch and *if* they raise their hands
- Students who are not following expectations will be taken back to the school to eat
- There will be an increased fine (\$3.00 for non-bronze students and \$1.50 for bronze students) for talking during silent lunch

### PM Transition Guidelines for Staff

PM transition is a crucial part of the day for both students and staff at Eliada Academy. It is imperative to maintain the safety of students and staff by conducting an orderly dismissal.

All staff are expected to be present during PM dismissal. If you are bringing students to dismissal, you are to stay with your group to monitor behaviors in the dismissal line. **If you are staff assigned specifically to PM duty and you are not able to be there (on time or at all) it is your responsibility to ask another staff**

**person to cover for you.** Once you have found an eager staff member to cover your PM duty position, notify Lindsey Morgan, Administrative Assistant, of the change.

There are two people assigned to PM duty who are responsible for the actual dismissal of each student. The **Point** person for PM duty is responsible for dismissing students from the line to their transportation and maintains the dismissal clipboard with the form stating which students ride with which transportation. Any irregularities will be noted on the form so there is ZERO confusion during this crucial part of the day.

The second person assigned to PM Duty is responsible for collecting the S&S crate and taking it to the dismissal area for students. This person then assists the Point person in transitioning students from the dismissal line to their transportation. Please remind your students that if *it* cannot stay with them during the day *it* WILL go in the crate so if there is a possibility of damage to the item, leave *it* at home. For students attending the After-School Program in the PARC building, staff will walk with those students to the PARC building.

❖ **Staff line up students in a quiet and orderly manner**

- Student dismissal is precisely 2:45pm. Staff should begin lining students up for quiet transition at 2:40 to arrive on the front porch at 2:45
- Students form a line in the classroom according to staff directions (boys in front and girls in the back)
- Staff direct students in a quiet and orderly manner to the front porch of the Academy (please consider designated stopping points for lengthy transitions)

❖ **Students line up on Sidewalk in front of Academy**

- Boys are to form a line to the left of the sidewalk
- Girls will line up on the right of the sidewalk
- Students are to have one foot on the grass and one foot on the sidewalk
- Students remain one arm's length from each other and staff
- Students are to remain quiet, orderly and in line until they are dismissed to their transportation

❖ **Personal belongings from AM Search and Seizure will be outside.**

- Students raise their hands and ask permission to collect their personals from the AM Search and Seizure crate
- Staff will assist students in collecting items from the crate

## CLASSROOM RULES

Be prepared for class

- Pen/pencil, binder, homework, balance sheet

Participate appropriately

- Complete all assigned work
- Raise your hand and wait for permission to speak or get out of seat
- Focus on yourself-IGNORE negative behaviors of others
- Respect and maintain appropriate boundaries with peers and staff
- Heads up; Eyes open

Focus time may be taken in designated area with staff permission

Eliada-issued uniforms must be worn at all times

- NO SAGGING
- Hang up your coat
- Hooded or over-sized sweatshirts are not allowed

Water in a clear bottle is the only beverage allowed in class

- No gum, candy, snacks, soda, juice, etc.

Restroom breaks will be taken during the last 15 minutes of class



## Search and Seizure

- Students may arrive at Eliada Academy for Search and Seizure at 7:40 AM.
- B1 and A3 will be used for Search and Seizure
- Once students have arrived in the perspective classrooms or area staff will record what time the student arrives and thoroughly search all pockets, shoes, waistbands, bra straps and binders. (See copy of log used)
- Students will also be searched using a security wand
- Any items that are confiscated (weapons, contraband, wallet, money, cell phone, chains, makeup) will be given to the student's Case Manager. The item may be returned to the students returned at the end of the day or to parents at the students' next Child and Family Team meeting.
- Students will be issued new, daily balance sheets during Search and Seizure.
- Teachings will begin during this period.
- Students will transition to their classrooms at 8:06 AM
- Students arriving after this transition will be considered tardy

**Writing Good Sedcare Notes**

Switch up goals. All students should have notes written on all goals throughout the month.

Notes should be based on updates. Updates should be thorough and clinical in nature.

Switch up which targets are written on each day. Many of the current notes are the same from day to day.

Do not talk about school, academics, etc.

If client has a goal related to ADHD, this should NOT be the primary goal written on. Many behaviors that appear to be related to ADHD may have a root in other diagnoses.

Use the 'cheat sheets.'

In progress on the goal box:

Related first sentence back to specific goal, rather than just noting goal, i.e. "Throughout the shift, the client did not exhibit an improvement in *symptoms of attentional difficulties*..." rather than "Throughout the shift, the client did not exhibit an improvement in *goals*."

List three that are tied to the targets of the goal. Should not mention academics, raising hand, school, etc.

**FOCUS ON CLIENT'S BEHAVIORS**

Intervention/Activity box:

Should use language in handout related to staff interventions

Should not mention academics, raising hand, school, etc.

Relate back to progress on goal box.

**FOCUS ON STAFF INTERVENTIONS**

Use time markers, such as "In the morning," "later in the day," "after lunch," and "at the end of the day."

Notes should be thorough and provide adequate detail of client's behaviors and staff's interventions, but should not be too lengthy.

**List of interventions to use for SEDCARE Service Notes**

Staff managed the environment by

Staff prompted

Staff discussed client behavior with

Staff used hurdle help to assist client

Staff used proximity to



Staff distracted client from

Staff redirected client to

Staff observed client become triggered by

Staff directed client to

Staff provided the opportunity for client to take time away after

Staff provided client the opportunity to discuss

Staff structured client's time to include

Staff assisted client in making a repair for

Staff assisted client in making restitution for

Staff engaged client in a discussion of his/her belief that

Staff validated client's feelings regarding

Staff discussed client's perception that

Staff used active listening to

Staff used reflective listening to

Staff assisted client in calming by

Staff assisted client to \_\_\_\_\_ to help drain off emotions

Staff clarified events/ expectations with client

Staff verbally expressed belief in client's ability to

Staff used a caring gesture to

Staff role played

Staff offered the feedback that \_\_\_\_\_ would be a more positive choice than \_\_\_\_\_

Staff discussed with client his/her awareness of his/her symptoms related to \_\_\_\_\_

Staff focused with client on developing/improving the social skill of \_\_\_\_\_

Staff provided client the opportunity to develop/improve communication skills by

Staff provided client the opportunity to practice \_\_\_\_\_, a coping skill that would assist him/her to

Staff provided client the opportunity to practice \_\_\_\_\_, an anger management skill.

Staff provided client the opportunity to practice \_\_\_\_\_, a stress management skill.

Staff engaged client in developing problem solving skills by

Staff assisted client in broadening his/her awareness of emotions/feelings by

Staff assisted client in linking his/her thoughts and feelings with his/her recent behavior of

Staff introduced the concept of \_\_\_\_\_ to client.

Staff assisted client in identifying his/her pattern of

Staff worked with client to develop a support plan to help him/her to

Staff assessed client's level of stability after he/she reported that \_\_\_\_\_ occurred at home.

Staff challenged client to

Staff used empathy statements to assist client

Staff encouraged client to \_\_\_\_\_ at home/with peers/with adults in order to

### SEDCARE Service Notes Cheatsheet

- Open SedCare
- Click on "**location**" in top right corner...select the **academy**
- This will pull up a list of names. Click on the one you want
- Click "**service doc**" and then "**service note**"
- Click "**New**"
- Pull down the list @ top right to select "**Day Tx**"...if you don't, it will remind ya ☺
- **Double click** on the **top left white box** that says whatever their "goal" is. **Select the goal** that the kid did well or not so well on for that day. This will move it over to the right.
- **Double click** on the **goal on right hand side** and **copy it (you have to do control "c" and "v")**
- **Paste it in the box below** after selecting whether the kid was "**positive**" or "**regressive**"
- This is just a guide for you to reference. When finished with this box, you can delete all words after "as evidenced by..."
- In this box you need **three sentences**. They all begin with "**Client demonstrated an (increase/decrease)** in (acute agitation/impulse control, whatever..) when the client (fill in the blank). This could look this way:
  - Client demonstrated an **increase** in impulse control when client was able to successfully raise client's hand before leaving client's seat OR
  - Client demonstrated a **decrease** in improved voice tone when client snapped at a staff member

- So, after this comes the fun part. Pick from the **left bottom box** whether you used a **positive** or a **corrective intervention** to support the child. **Double click this** and again, it will **move** it to the **right side** for you.
- **Double click** the **right side box** where this intervention was placed. It will open it up for you and you can delete the two sentences that say something like “provider’s intervention” and “client’s something...”
- Use this space to write **four small paragraphs**. If it was a positive intervention you need at least 3 **positive paragraphs** and you can include **one negative**, if you noticed one. Same way with the corrective intervention...3 **corrective sentences** and **one positive**, if it applies. These paragraphs should look like this:
  - Staff approached client when client failed to use impulse control. Staff used reflective listening to understand the client’s feelings. Staff issued a program-based consequence and directed the client to always raise client’s hand before leaving the client’s seat. OR
  - Staff praised the client when client maintained appropriate boundaries. Staff issued client a program-based reward and encouraged the client to continue to improve in this area. Staff discussed with client the ways in which client could practice improving on this skill.
- **At the end of each staff intervention, you must type “Throughout the shift staff continued to monitor client’s behaviors”**
- Keep in mind that SEDCARE is SLOWWWWWWWWW. If you double click on something and it does not open, breathe and count to five and it may cooperate.

Do you like to get paid? Sure you do! So please – it is imperative that all note-writing staff play THE MEDICAID GAME! There are no bright lights, music, or coiffed-to-the-max hosts, but agencies that win the game get reimbursed, others don’t. Apparently there was a momentary improvement in quality and timeliness after Jan sent out an email a while ago but the problems continue.

So, again, please keep in mind the following:

- ✚ Notes must be *treatment-focused* and *relevant to at least one of the targets under the PCP goal(s)* that the client is working on. Medicaid does not care if a client did their homework, wore their uniform, or likes school.
- ✚ Our kids are *clients in treatment*, NOT *students in school* or in an *academic* setting. Do not refer to classroom, class work, school work, academics, or anything similar *unless* it is *specifically* part of a goal or target.
- ✚ *Re-read* what you’ve written to see if it makes sense, grammatically and therapeutically, before submitting. Most errors will be caught simply by doing this.
- ✚ *Check your spelling.*

Incomplete, incorrect, or late notes put a real hurtin’ on our case managers. Because of time pressures they have been correcting notes rather than putting it back on you. This cannot continue. If you need guidance on writing

notes, please ask. Staff who are regularly late in submitting notes will be subject to verbal warnings, tasing, ridicule from their peers, or worse.

### About writing Notes:

Currently we use preventive, positive, corrective, and intensive interventions.

1. You can use variations of these sentences “Staff engaged client in a corrective intervention after s/he \_\_\_\_\_”  
“Staff initiated an intensive intervention (on-going) after client (put something that they did) \_\_\_\_\_.”
2. When students earn consequences (either positive or negative) for behavior please use variations of this sentence: “Staff issued corrective/positive consequences after client (put something that they did) \_\_\_\_\_.”
3. Do not refer to school, or schoolwork. In notes speak of tasks and day treatment environment.
4. Note must reflect service provided including length of time/day. This means that one sentence a block is not enough information about what happened during the entire block, nor does it reflect a 6 hr day.
5. Events that occur during a day like restrictive intervention, or field trips, team meetings, meeting with staff or advocates need to go in note.
6. If you have questions about what you are writing, please ask a case manager for clarification.

**ALL SERVICE NOTES ARE TO BE COMPLETED WITHIN 24 HOURS OF THE BLOCK/INTERVENTION.**

- **Action Verbs:**
- used active listening
- provided feedback
- prompted
- praised
- processed
- discussed
- observed
- role modeled
- assisted
- provided reinforcement
- imposed consequences
- provided instruction
- encouraged
- reminded
- challenged
- problem solved
- reviewed
- clarified
- explored
- confronted
- role played
- directed
- provided structure
- utilized planned ignoring
- empathized
- redirected
- facilitated
- provided opportunity
- used constructive criticism
- 
- **Action Verbs:**
- used active listening
- provided feedback
- prompted
- praised
- processed
- discussed
- observed
- role modeled
- assisted
- provided reinforcement
- imposed consequences
- provided instruction
- encouraged
- reminded
- challenged
- problem solved
- reviewed
- clarified
- explored
- confronted
- role played
- directed
- provided structure
- utilized planned ignoring
- empathized
- redirected
- facilitated
- provided opportunity
- used constructive criticism
- 
- **Action Verbs:**
- used active listening
- provided feedback
- prompted
- praised
- processed
- discussed
- observed
- role modeled
- assisted
- provided reinforcement
- imposed consequences
- provided instruction
- encouraged
- reminded
- challenged
- problem solved
- reviewed
- clarified
- explored
- confronted
- role played
- directed
- provided structure
- utilized planned ignoring
- empathized
- redirected

## Eliada Homes, Inc.

### COMMONLY USED ACRONYMS

#### Federal, State and Local Agencies:

- CMS – Centers for Medicare and Medicaid Services (federal Medicaid)
- COA – Council on Accreditation (national accreditation for our agency and treatment and foster care services)
- NAEYC – National Association for the Education of Young Children (national accreditation for child development services)
- DMA – Division of Medical Assistance (state Medicaid)
- DHHS – Department of Health and Human Services
- DSS – Division of Social Services
- DMH – Division of Mental Health
- DJJDP – Department of Juvenile Justice and Delinquency Prevention
- SPA – State Plan Amendment (plan that DMA submits to CMS for federal approval of North Carolina's Medicaid services)
- LOC – Legislative Oversight Committee
- IMD – Institution for Mental Disease
- LME – Local Management Entity
- WHN – Western Highlands Network (our local LME covering 8 county area)

#### Eliada Services:

- Dtx-Day Treatment
- PRTF – Psychiatric Residential Treatment Facility (Reynolds, Lions and Earl cottages)
- FC – Foster Care
- TFC – Therapeutic Foster Care (mental health service)
- FFC – Family Foster Care (for children in DSS custody)
- FPP – Family Partnership Program (our community support program)
- CS – Community Support
- NYPUM – National Youth Project Using Minibikes
- TASC – Therapeutic Animal Stewardship Cooperative
- IL – Independent Living

#### Job Positions:

- CEO – Chief Executive Officer
- COO – Chief Operations Officer
- CFO – Chief Financial Officer
- PD – Program Director
- PM – Program Manager

- CM – Case Manager
- RC – Residential Counselor
- ETS-Education Treatment Specialist
- CSP – Community Support Professional
- RISE – Residential Interns Seeking Excellence (internship program for college graduates; live on campus and work in residential for one year)
- PRN – As needed staff for residential and day treatment

## **Common Treatment Terms:**

- DBT – Dialectical Behavior Therapy (treatment approach used primarily in Reynolds cottage; some DBT skills taught in other cottages)
- ODD – Oppositional Defiant Disorder
- PTSD – Post Traumatic Stress Disorder
- RAD – Reactive Attachment Disorder
- ADHD – Attention Deficit Hyperactivity Disorder
- SA – Substance Abuse
- LCSW – Licensed Clinical Social Worker
- LPC – Licensed Professional Counselor
- TCI – Therapeutic Crisis Intervention (crisis management model taught to all residential and day treatment staff; includes de-escalation and problem solving skills as well as physical interventions)
- MDT – Multidisciplinary Team (treatment oversight team that meets weekly in residential; includes psychiatrist, psychologist, residential director and managers; case managers; clinician; nurse manager)
- LSI – Life Space Interview (problem solving model taught as part of TCI)
- CFT – Child and Family Team (each student has a treatment team consisting of their family/guardian; CSP; Eliada staff; and other professionals involved with their life)
- PCP – Person Centered Plan (written plan developed with each student and their family/guardian; includes treatment goals and interventions)
- QP – Qualified Professional (requires BS degree in human services and 2 years experience in behavioral health, or BS degree in non human services and 4 years experience)
- AP – Associate Professional (BS degree without experience)
- PP – Paraprofessional (no college degree)

## Some often used files

- S-Drive:
  - Eliada Academy:
    - Schedules
    - Super Model
    - ICMP
    - Staff Search and Seizure



# Basic Demographics

Eliada Academy provided services to a total of 162 students during the 2010 – 2011 fiscal year. For the 2009 – 2010 fiscal year, the total number of students served was 148. PRTF served 103 students, which is an increase of twelve students. Day Treatment served 59 students, 12 fewer than the previous year.

Program Totals		
	Frequency	Percent
Earl	14	7.2
Reynolds	26	13.3
Lions	25	12.8
Reuter	22	11.3
Cummings	16	8.2
Day Tx	59	30.3

## Gender

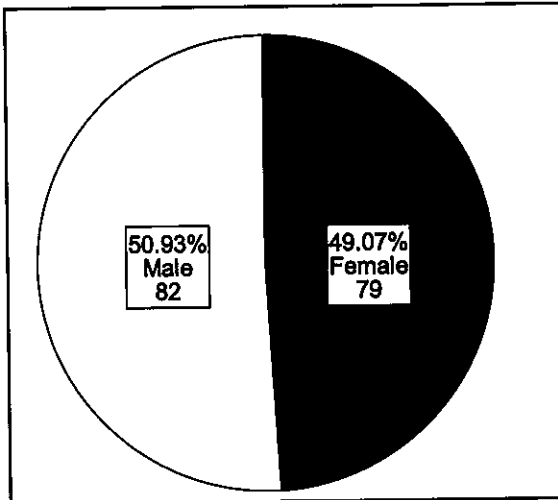

Of the 162 students served, 79 students were female and 82 were male. Last fiscal year there were considerably more females served than males. It is interesting to note that while the gender of the students was evenly split, Eliada has 4 co-ed cottages, 1 all-female cottage and 0 all-male cottages.

“Eliada’s awesome. It’s helped me a lot!”

~Student at discharge

Forty-nine percent of students are from Buncombe County and eleven percent are from surrounding counties such as Henderson, Haywood and Madison. The racial demographics for Eliada’s treatment services overall are representative of Buncombe County’s racial demographics which is as follows:

### Buncombe Co. Racial Demographics (2010)\*

Race	Percentage
Caucasian	87.4%
African American	6.4%
Hispanic	6.0%
Asian	1.0%
Native American	.4%
Pacific Islander	.1%
Two or more races	2.1%

For the 2010 – 2011 year, Eliada recorded an increase of 3.87% in the number of students of African American origin served.

\* Table from quickfacts.census.gov

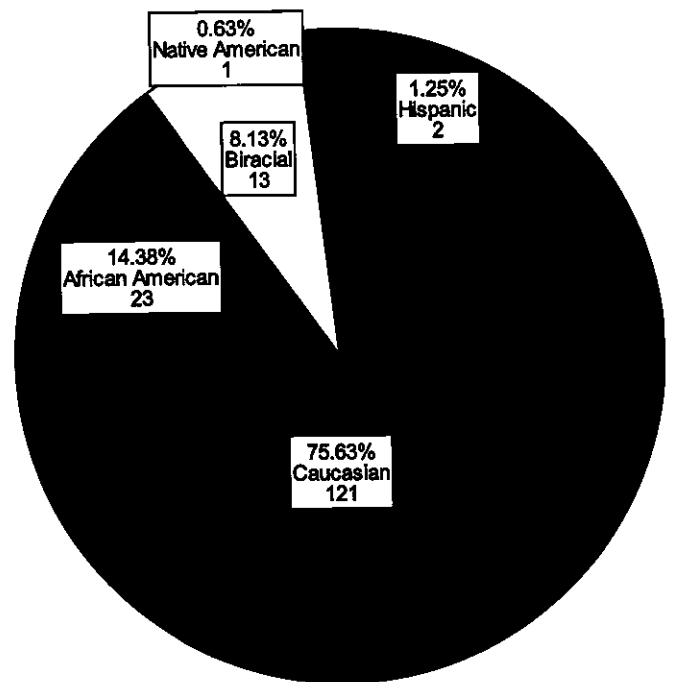

Race



Eliada Homes, Inc.

## Eliada Academy Day Treatment

*Individualized, Compassionate, Effective Treatment  
for Children Ages 8 to 17*

*Openings Anticipated in January 2012*  
Referrals now being accepted for waitlist.

Academic supports include:

- ✦ Title I reading and math assistance
- ✦ Certified English, Math and Elementary teachers
- ✦ Fine arts program
- ✦ Classroom for ASD kids
- ✦ Experienced, dedicated staff
- ✦ Comprehensive transition program

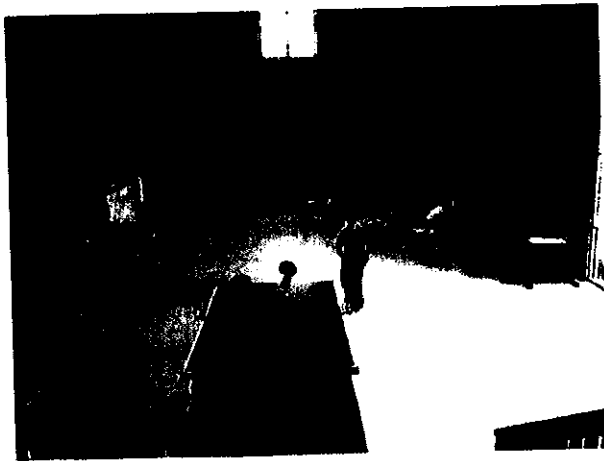
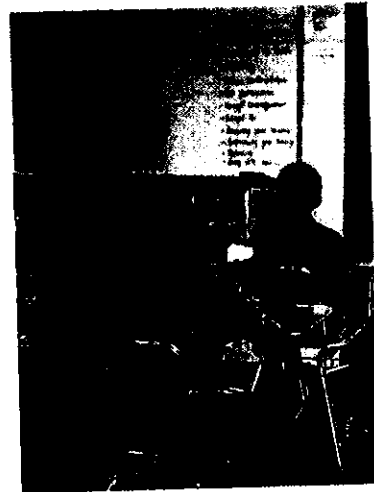

Therapeutic supports include:

- Social and behavioral skill development
- Weekly groups targeted to specific needs
- Full-time licensed therapist
- Animal stewardship
- Minibike program
- Newly-remodeled fitness center
- Nature trails
- Field trips (e.g., Navitat zipline tours!)

*A full day of structured, treatment-focused, kid-friendly  
therapeutic activities in a beautiful setting.*

For more information and admission criteria, please contact  
Chelsie Short at (828) 254-5356 ext. 307  
or email [referral@Eliada.org](mailto:referral@Eliada.org)

# Psychiatric Residential Treatment Facility (PRTF) Services at Eliada

## IMMEDIATE PLACEMENT AVAILABLE

For more information, call Agape Powell:  
828-254-5356 Ext: 332  
Intake Department: [referral@eliada.org](mailto:referral@eliada.org)  
[www.eliada.org](http://www.eliada.org)

### Program Elements:

- Serves adolescents and pre-adolescents
- Co-ed and female only settings
- Two cottages are secured and three are unlocked
- Behavioral model designed to build appropriate social skills
- Individual, Family and Group Therapy

### Experiential Activities:

- NYPUM (National Youth Program Using Mini-Bikes)
- TASC (Therapeutic Animal Stewardship Cooperative)
- Recreation facility with climbing wall & fully equipped weight room
- Intramural athletics



Eliada Homes, Inc.  
*Helping Children Succeed*  
2 Compton Drive  
Asheville, NC

